

BLUE MOUNTAIN
COMMUNITY COLLEGE

2008-2009 Academic Catalog

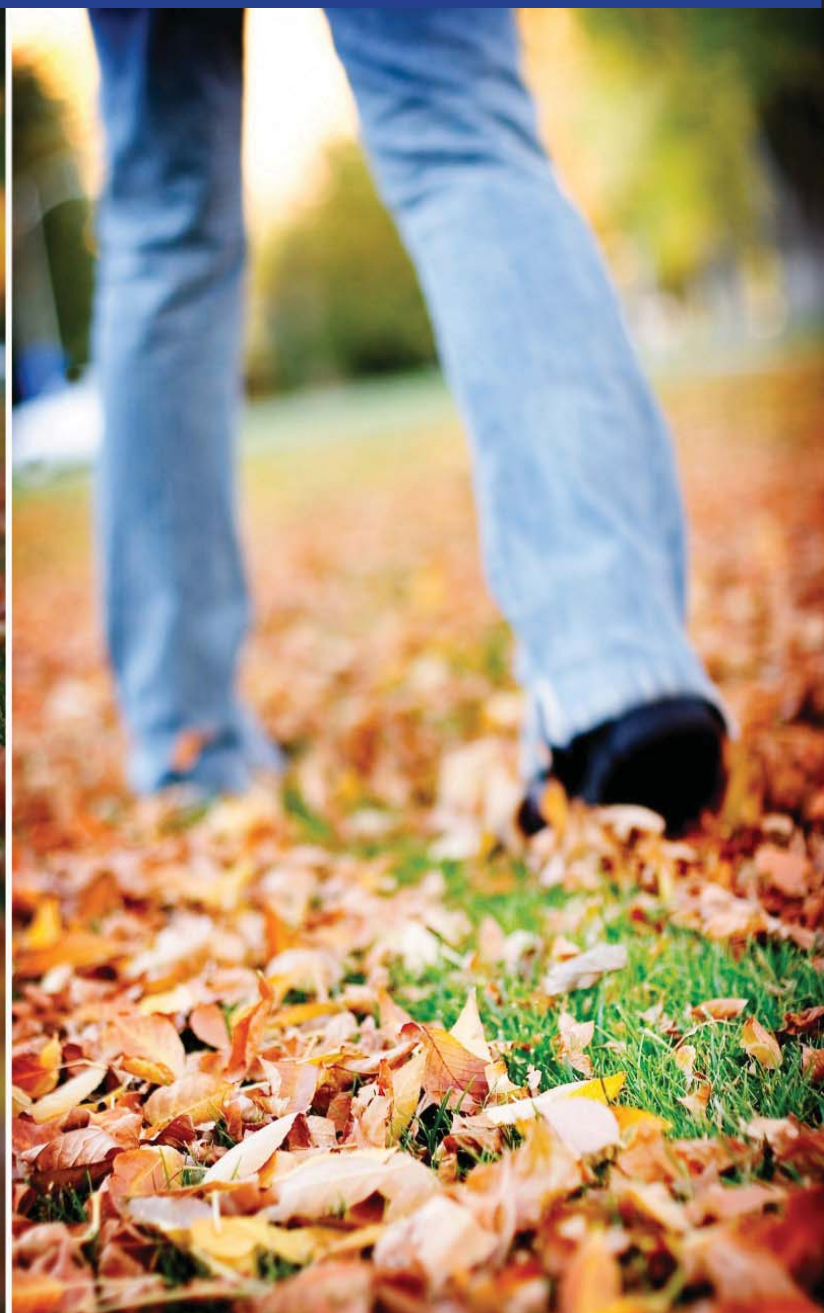

2008-2009 Academic Year Calendar	Summer Term 2008	Fall Term 2008	Winter Term 2009	Spring Term 2009
Advising Begins	May 27	May 27	November 17	March 2
Registration Begins	June 2	June 2	December 1	March 9
Classes Begin	June 23	September 29	January 5	March 30
Last Day to Add/Drop a Class with a Full Refund (dates vary for differentially scheduled classes)	June 27	October 3	January 9	April 3
Late Day to Pay Tuition Without A Late Fee	June 27	October 3	January 9	April 3
Late Payment Fees Begin (3% of unpaid balance with a minimum charge of \$10 and a maximum charge of \$75. Fees assessed monthly until paid.)	June 28	October 4	January 10	April 4
Graduation Application Due		October 31 for winter and spring 2009 graduation	March 6 for summer 2009 graduation	May 29 for fall 2009 graduation
Last Day to Withdraw from Class	Last day of classes before finals begin	December 5	March 13	June 5
Events		Welcome Back BBQ & Constitution Day October 1	Check Web Calendar	Spring Fling May
Holidays and Campus Closures	Independence Day July 4	Labor Day September 1 Employee Training September 15-19 Round-Up September 12 Veterans' Day November 11 Thanksgiving November 27-28 Winter Break Campus Closed December 24-31	New Year's Day January 1 Martin Luther King Day January 19 Spring Break (faculty and students) March 23-27 Campus Closed March 27	Memorial Day May 25 Summer Break (faculty and students) June 15-19
Final Examinations	6 week courses: July 28-31 10-week courses August 25-28 Check syllabus for dates	December 8-11	March 16-19	June 8-11
End of Term	August 28	December 12	March 20	June 12
Commencement				June 12

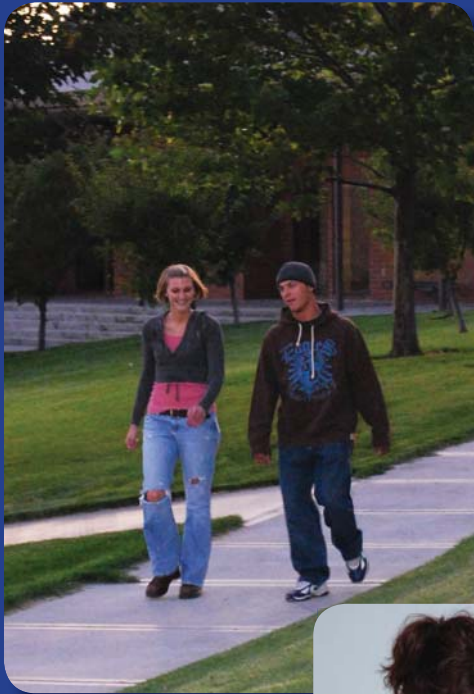

BLUE MOUNTAIN COMMUNITY COLLEGE
2411 NW Carden - PO Box 100
Pendleton, OR 97801
www.bluecc.edu

2009-2010 Academic Year Calendar	Summer Term 2009	Fall Term 2009	Winter Term 2010	Spring Term 2010
Advising Begins	May 18	May 18	November 16	February 22
Registration Begins	June 1	June 1	December 7	March 8
Classes Begin	June 22	Mon, September 28	Wed, January 6	Mon, March 29
Last Day to Add/Drop a Class with a Full Refund (dates vary for differentially scheduled classes)	June 26	October 2	January 12	April 2
Last Day Deferred Payment Plan Offered w/o Late Fee	June 26	October 2	January 12	April 2
Last Day to Pay Tuition Before a Late Fee is Assessed (3% of unpaid balance with a minimum charge of \$10 and a maximum charge of \$75 per term. Fees assessed monthly until paid.)	June 26	October 2	January 12	April 2
Graduation Application Due	May 29 for fall 2009 graduation	August 3 for winter 2010 graduation	November 6 for spring 2010 graduation	November 6
Last Day to Withdraw from Class	Last day of classes before finals begin	December 11	March 12	June 4
Events		Welcome Back BBQ & Constitution Day	Check Web Calendar	Spring Fling in May
Holidays and Campus Closures	Independence Day July 3	Labor Day September 7 Employee Training September 21 - 23 Round-Up September 18 Constitution Day & Welcome Back BBQ October 9 Veterans' Day November 11 Thanksgiving November 26-27 Winter Break December 24 – Jan 1	New Year's Day January 1 Martin Luther King Day January 18 Spring Break (faculty and students) March 22 - 25 Campus Closed March 26	Memorial Day May 31 Summer Break (faculty and students) June 14 - 18
Final Examinations	6 week courses: July 27 – 30 10 week courses: August 24 - 27 Check syllabus for dates	December 14 - 17	March 15 - 18	June 7 - 10
End of Term	August 27	December 18	March 19	June 11
Commencement				June 11

2008 - 2009

Academic Catalog

Blue Mountain Community College

Website: www.bluecc.edu

CENTERS IN DISTRICT

BMCC BAKER COUNTY

3275 Baker Street
Baker City, OR 97814
Phone: 541-523-9127
Fax: 541-523-9128
Email: bmccbaker@bluecc.edu

BMCC HERMISTON

980 S.E. Columbia Drive
Hermiston, OR 97838
Phone: 541-567-1800
Fax: 541-567-1020
Email: bmcchermiston@bluecc.edu

BMCC MILTON-FREEWATER

311 N. Columbia
Milton-Freewater, OR 97862
Phone: 541-938-4082
Fax: 541-938-3763
Email: bmccmiltonfreewater@bluecc.edu

BMCC NORTH MORROW COUNTY

P.O. Box 939 / 300 N.E. Front Street
Boardman, OR 97818
Phone: 541-481-2099
Fax: 541-481-3990
Email: bmccnorthmorrow@bluecc.edu

BMCC SOUTH MORROW COUNTY

P.O. Box 21
Ione, OR 97843
Phone: 541-422-7040
Fax: 541-422-7015
Email: bmccsouthmorrow@bluecc.edu

BMCC PENDLETON

2411 N.W. Carden Avenue/P.O. Box 100
Pendleton, OR 97801
Phone: 541-276-1260
Fax: 541-278-5871
Email: getinfo@bluecc.edu

CONTRACTED OUT OF DISTRICT CENTERS (CODs)

BMCC GRANT COUNTY

835-B S. Canyon Blvd.
John Day, OR 97845
Phone: 541-575-1550
Fax: 541-575-2920
Email: getinfo@bluecc.edu

BMCC WALLOWA COUNTY

107 S.W. 1st
Enterprise, OR 97828
Phone: 541-426-4109
Fax: 541-426-6059
Email: getinfo@bluecc.edu

IMPORTANT CONTACTS

Section 504 Coordinator—PO Box 100—Pendleton, OR 97801—541-278-5931

Title II—Senior Director of College Preparatory Programs—PO Box 100—Pendleton, OR 97801—541-278-5804

Title IX—Associate Vice President, Enrollment Management—PO Box 100—Pendleton, OR 97801—541-278-5774

For the most recent updates to this catalog, please view online at: <http://www.bluecc.edu>

**Blue Mountain Community College is accredited by the
Northwest Commission on Colleges and Universities**

If you would like a printed copy of this catalog, please call 541-278-5759 or email getinfo@bluecc.edu

ABOUT THIS CATALOG: The information contained in the current BMCC Academic Catalog and quarterly Schedule of Classes reflects an accurate picture of BMCC at the time of publication. However, conditions can and do change. Therefore, the college reserves the right to make any necessary changes in the matters discussed herein, including procedures, policies, calendar, curriculum, course content, emphasis and cost. Students enrolling in BMCC classes are subject to rules, limits and conditions set forth in the current Academic Catalog; Schedule of Classes; Statement of Student Rights and Responsibilities, and other official publications of the college.

TABLE OF CONTENTS

INTRODUCTION.....	3		
PRESIDENT’S WELCOME.....	3	<i>Non Traditional College Credit</i>	<i>19</i>
VISION STATEMENT.....	3	<i>Transfer Credits.....</i>	<i>20</i>
MISSION STATEMENT	3	<i>Appeal of Graduation Requirements</i>	<i>20</i>
STRATEGIC PLAN AND GOALS.....	3	<i>Graduation.....</i>	<i>20</i>
GETTING STARTED	4	COLLEGE COSTS.....	21
DEGREES AND PROGRAMS OFFERED	5	<i>Tuition and Fees.....</i>	<i>21</i>
ACCREDITATION STATEMENTS	5	<i>Paying Tuition.....</i>	<i>22</i>
WELCOME TO BMCC.....	6	<i>Tuition Refund Policy.....</i>	<i>22</i>
WHO WE ARE.....	6	FINANCIAL ASSISTANCE.....	22
OUR HISTORY	6	<i>Federal and State Aid.....</i>	<i>22</i>
LIVING IN EASTERN OREGON.....	7	<i>Other Financial Assistance.....</i>	<i>23</i>
OUR LOCATIONS.....	7	<i>Veterans’ Educational Benefits.....</i>	<i>24</i>
<i>BMCC Pendleton</i>	<i>7</i>	SERVICES AND PROGRAMS FOR STUDENTS.....	26
<i>BMCC Baker County.....</i>	<i>8</i>	ACADEMIC SERVICES.....	26
<i>BMCC Hermiston.....</i>	<i>8</i>	<i>Testing Services</i>	<i>26</i>
<i>BMCC Milton-Freewater.....</i>	<i>9</i>	<i>Academic Advising.....</i>	<i>26</i>
<i>BMCC Grant County.....</i>	<i>9</i>	<i>Timberwolves Introduction</i>	<i>26</i>
<i>BMCC North Morrow County.....</i>	<i>9</i>	<i>Bookstore</i>	<i>26</i>
<i>BMCC South Morrow County.....</i>	<i>9</i>	<i>Copy Center</i>	<i>26</i>
<i>BMCC Wallowa County.....</i>	<i>9</i>	<i>Student Union Cafeteria.....</i>	<i>27</i>
DISTANCE EDUCATION.....	10	<i>Library</i>	<i>27</i>
STUDENT INFORMATION	11	<i>Services for Students with Disabilities</i>	<i>27</i>
STUDENTS’ RIGHTS AND RESPONSIBILITIES.....	11	<i>Tutoring Program.....</i>	27
<i>Student Right-to-Know Information.....</i>	<i>11</i>	<i>TRiO Student Support Services</i>	<i>27</i>
<i>Statement of Non-Discrimination and Grievance</i>		<i>Co-Curricular Activities.....</i>	<i>28</i>
<i>Procedure</i>	<i>12</i>	COLLEGE PREPARATORY PROGRAMS.....	29
<i>Drug and Alcohol Statement.....</i>	<i>12</i>	<i>Adult Basic Education (ABE).....</i>	<i>29</i>
<i>Family Educational Rights and Privacy Act.....</i>	<i>12</i>	<i>Adult High School Diploma Program (AHSD)</i>	<i>29</i>
GENERAL INFORMATION.....	13	<i>English as a Second Language (ESL).....</i>	<i>29</i>
ADMISSION POLICIES	13	<i>General Educational Development (GED)</i>	<i>29</i>
OREGON RESIDENCY REQUIREMENTS	13	<i>JOBS Program.....</i>	29
ADMISSIONS PROCEDURES.....	14	<i>College Preparation Courses</i>	29
<i>Degree and Certificate Programs</i>	<i>14</i>	OTHER PROGRAMS.....	30
<i>International Admissions</i>	<i>14</i>	<i>Continuing Education.....</i>	30
<i>Non-Degree Admissions</i>	<i>14</i>	<i>Community Education.....</i>	30
<i>Placement Assessment.....</i>	<i>14</i>	ACADEMIC PARTNERSHIPS	30
<i>Computer Literacy Requirement.....</i>	<i>15</i>	<i>Business Partnerships</i>	30
<i>Adult Basic Education and General Educational</i>		<i>High School Partnerships.....</i>	31
<i>Development Admissions</i>	<i>15</i>	<i>Inter-College Partnerships.....</i>	31
REGISTRATION INFORMATION.....	15	<i>Articulated Degree Programs</i>	31
<i>Degree-Seeking Students</i>	<i>15</i>	CAREER PATHWAYS.....	34
<i>Non-Degree Seeking Students.....</i>	<i>15</i>	DEGREES AND CERTIFICATES	36
<i>Course Numbers.....</i>	<i>15</i>	<i>Statement of Student Outcomes</i>	<i>36</i>
<i>Credits.....</i>	<i>15</i>	TRANSFER OPTIONS	37
<i>Attendance</i>	<i>16</i>	<i>Associate of Arts Oregon Transfer Degrees</i>	<i>37</i>
<i>Auditing Classes</i>	<i>16</i>	<i>Associate of Science Degree</i>	<i>38</i>
<i>Drop/Withdrawing from Classes</i>	<i>16</i>	<i>Oregon Transfer Module</i>	<i>39</i>
<i>Withdrawal from College</i>	<i>16</i>	COLLEGE TRANSFER COURSES	40
<i>Withdrawal for Military Duty.....</i>	<i>16</i>	MATH & WRITING PROGRESSION CHARTS.....	45
ACADEMIC INFORMATION.....	16	DEGREE AND CERTIFICATE OPTIONS.....	46
<i>Grading System.....</i>	<i>16</i>	<i>Associate of Applied Science Degrees</i>	<i>47</i>
<i>Enrollment Status.....</i>	<i>17</i>	<i>Associate of General Studies Degree.....</i>	<i>58</i>
<i>Grade Changes.....</i>	<i>18</i>	<i>Certificates.....</i>	<i>59</i>
<i>Grade Appeal Process.....</i>	<i>18</i>	COURSE DESCRIPTIONS	66
<i>Grade Point Average (GPA) Renewal Policy.....</i>	<i>18</i>	BMCC BOARDS AND PERSONNEL.....	98
<i>Final Examinations.....</i>	<i>18</i>	GLOSSARY.....	105
<i>Academic Achievement Recognition</i>	<i>18</i>	BMCC CAMPUS MAPS.....	111
<i>Academic Notification: Warning/ Probation/</i>		BMCC PHONE DIRECTORY	117
<i>Suspension</i>	<i>19</i>		

Introduction

President's Welcome...



Start your future at BMCC! Whether you want to earn a degree or a certificate, to complete your high school education, to improve your English proficiency, or perhaps to take some self-improvement courses, we have classes to meet your needs. If you work during the day, you may want to look at our expanding list of night and weekend offerings. We also are improving our list of distance education courses so we can better serve students throughout northeastern Oregon. With our new online enrollment system, you can register for classes without leaving home.

Don't let a lack of money stop you from enrolling; we have financial assistance experts to help you obtain loans and to show you how to apply for grants and scholarships that you might not have to repay. You will be pleased to see how helpful people are at BMCC. From our front-line staff to our faculty and administrators, the people you will meet at BMCC all want you to succeed. If you think your math or writing skills are a bit rusty, don't worry: we have tutors to work with you so you can quickly become ready for college-level work.

Remember, a college certificate or degree will add tens of thousands of dollars to your wallet over your lifetime, so the time and energy you devote to your education are really worthwhile. Give us a call today, and let us help you succeed.

John H. Turner
President
Phone: 541-278-5950
Email: jturner@bluecc.edu

Vision Statement

Blue Mountain Community College will be the leading educational and training institution in eastern Oregon.

Mission Statement

Blue Mountain Community College will realize its vision by providing high-quality programs for college preparation, college transfer, career and technical training, workforce development, and self-improvement that will strengthen the economy and provide opportunities for personal and professional growth.

BMCC provides dynamic and innovative programs and delivery methods in response to the changing needs of our customers: the students, businesses, industries and communities of eastern Oregon.

Strategic Plan and Goals

The Blue Mountain Community Board of Education reviews the 2004-2014 strategic plan on an annual basis and will accomplish the goals listed below.

BMCC will focus on student success in a premiere learning environment and:

- Enhance student support
- Increase access through innovate delivery methods and systems (fiscal and regional)
- Increase resources for financial growth and stability
- Strengthen the institution through assessment and planning
- Enhance relevant and comprehensive curriculum
- Develop employees to their highest potential
- Grow community partnerships
- Integrate and expand marketing and recruitment

Blue Mountain Community College

GETTING STARTED

Get Started at... Blue Mountain Community College

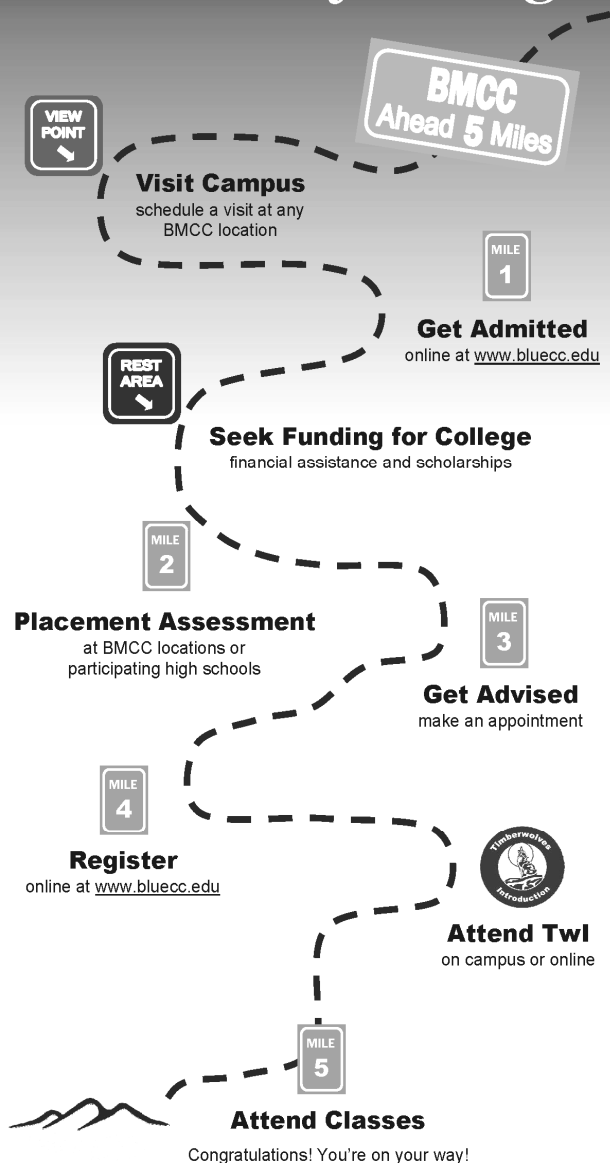

At Blue Mountain Community College we have an open-door admission policy, which allows students to be admitted to BMCC as long as they can benefit from our instruction. If you go to the BMCC Website at www.bluecc.edu and click on the "Get Started" button, you will find the road map pictured above. Each marker is a link to information and forms that will help you complete the admissions and registration process.

Apply for admission – online or in person. Online you will click on "Mile 1" and follow the instructions or you can pick up a paper admissions form at the BMCC Service Center in Morrow Hall.

Request Transcripts. If you have attended college prior to coming to BMCC and would like those credits to be considered toward your BMCC degree, you will need to request an official transcript be sent to BMCC. You also need to fill out a "Transcript Evaluation Request" form. You can find it on the BMCC Website under student forms. Turn in the completed form at the Service Center.

Take the Placement Assessment. As a new student at BMCC, you must complete placement assessments in math, writing, reading and computer literacy. If you have already done this, or completed coursework at another college, contact the BMCC Advising and Testing Center at 541-278-5931 for further information.

Apply for financial assistance. The easiest way to get the most complete information concerning financial assistance is to go to the BMCC Website. For more information, call 541-278-5759, e-mail finaid@bluecc.edu, or stop by the Service Center in Morrow Hall on the Pendleton campus.

Meet with an advisor. As a new student you must work with an advisor before registering. Please contact the Advising and Testing Center at 541-278-5931 to make an appointment.

Register for classes. Once you have met with your advisor, go to www.bluecc.edu, click on *Student Wolfweb* and login to your personal account. Once there, click on *Register for Classes*.

Pay for classes. You can pay your bill at any BMCC center or online by going to your personal account on the Student WolfWeb and paying with a credit or debit card. See our Website for payment methods and deadlines.

Purchase textbooks. You can purchase your textbooks at the BMCC Bookstore in Pendleton, online at our Website, or at BMCC locations where the course is offered. If you have any questions, please call the bookstore at 541-278-5733.

Attend a Timberwolves Introduction (TwI). As a new student, you will be required to attend this interactive information session, where you can get to know BMCC and learn how to be successful academically.

Blue Mountain Community College

Degrees and Programs Offered

Blue Mountain Community College provides educational opportunities through the following programs:

Lower-Division Collegiate Transfer Programs

Associate of Arts Oregon Transfer (A.A.O.T.) Degree
Associates of Science (A.S.) Degree
Associate of General Studies (A.G.S.) Degree

Career and Technical Programs A.A.S/Certificate

Provide students with training to qualify them for work in specific fields. One-year certificates and/or two-year associate of applied science degrees are offered in the following areas:

Accounting	Early Childhood Education
Administrative Assistant: General, Legal, Medical	Electrician Apprenticeship Technologies
Agriculture Business, Production, Crops, Livestock	Hospitality, Tourism, and Management
Business Administration and Management	Mechanics and Maintenance Technology Apprenticeship
Civil Engineering Technology	Nursing
Construction Trades, General Apprenticeship	Office Assistant: General, Medical
Dental Assisting Technician Certificate	Paraeducator
Diesel Technology	Retail Management
Drafting Technology	

College Preparatory Programs

Adult Basic Education (ABE)	English as a Second Language (ESL)
Adult High School Diploma (AHSD)	JOBS Program
General Educational Development (GED)	

Business and Industry Training

Provide business and industry training customized to meet the needs of students and the specific needs of local businesses, organizations, and government agencies, includes the Small Business Development Center (SBDC).

Inter-College Partnerships

CUESTE: Teacher Education Program with Eastern Oregon University
Eastern Oregon Collaborative Colleges Council with Treasure Valley Community College and Eastern Oregon University
Medical Laboratory Technician (MLT) Program with Wenatchee Valley Community College
Diagnostic Imaging Technology (DIT) with Linn-Benton Community College
Oregon State University Dual Admission

Accreditation Statements

BMCC is a public, two-year, coeducational college accredited through the Northwest Commission on Colleges and Universities, 8060 165th Avenue N.E., Suite 100, Redmond, WA 98052, phone: 425-558-4224.

Programs at the college are approved by the Oregon Department of Education, to offer education and training under the various public laws pertaining to financial assistance to veterans.

The nursing program is accredited by the Oregon State Board of Nursing.

The dental assistant program is accredited by the American Dental Association.

The emergency medical technician classes are accredited by the Oregon Department of Education.



Welcome to BMCC

At Blue Mountain Community College, you can begin your educational journey and go just about anywhere from here. You can transfer to a university and earn a four-year degree through our partnership arrangements, obtain professional skills for a new career, enrich your life with a special interest class, or upgrade your employability. It is all available at Blue Mountain Community College, where we are committed to each student's success.

Who We Are

Since we first opened our doors forty-five years ago, thousands of students have received degrees from our institution. We annually serve almost 900 full-time students and more than 9,600 students who take classes on a part-time basis.

Training outstanding citizens and leaders is a continuing priority for our faculty. Our full-time and part-time faculty members are the heart of our institution. At BMCC, all classes are taught by highly qualified experts in their subjects, not by teaching fellows or graduate assistants. Most instructors hold master's or doctoral degrees in their discipline and/or vocational certificates in their area of expertise. In addition, instructors have a broad range of experience in their subject areas that makes classroom and laboratory instruction applicable to the real world. The faculty and staff at Blue Mountain offer you a personal approach to your education. Our classes are small, yet dynamic, allowing for individualized attention and mastery of the subject, as well as for personal success. This personal approach to education extends beyond the classroom to include a variety of distance education options. Without leaving their homes, students may enroll in many course offerings through video courses, home study, our online Website, or live interactive television.

The BMCC service area covers approximately 18,000 square miles. Morrow, Umatilla, and Baker counties

constitute BMCC's tax district; and Wallowa and Grant counties contract with BMCC for educational services. Coordinators based in communities throughout the area, including Pendleton, Milton-Freewater, Hermiston, Boardman, Baker City, Lone, John Day, and Enterprise, assess their communities' needs and build a schedule each term that addresses those needs. This approach keeps us linked to our communities and provides the localized service that they need.

Our History

Blue Mountain Community College was established on July 1, 1962, after winning an overwhelming five-to-one vote of confidence by the residents of Umatilla and Morrow counties.

The college opened its doors in September of that same year. Vocational-technical courses were initially taught at Pendleton's John Murray Junior High School, while college transfer programs were added a year later. In 1965, Blue Mountain Community College moved to its present campus high on the north hill overlooking Pendleton. Within ten years, the original construction plans for the college were completed. In September 1992, the college purchased Columbia Hall in Hermiston to accommodate a growing student population in western Umatilla County. In October 1993, the college created a center in Milton-Freewater by leasing the former US Bank Building. In 1994, the Milton-Freewater Continuing Education Office and Basic Skills Center moved to the same location.

Fall term 1995 marked the beginning of BMCC's distance education program. While the college had offered telecourses for a number of years, newer mediums such as videotapes, the Internet, and ED-NET expanded the options of potential students who were bound by constraints of time or location.

In November 1998, the voters in Morrow and Umatilla counties passed a bond measure for facility expansion in district growth areas. The bond financed expansion of the centers in Hermiston and Milton-Freewater and the opening of the BMCC Morrow County center in Boardman. The Pendleton campus expansion included new technical agriculture buildings, a new science and technology building, and the remodeling and upgrading of older facilities. A ballot measure in March 2000 annexed Baker County into the BMCC district. Classes at BMCC Baker County began in the fall of 2000.

Blue Mountain Community College looks forward to celebrating its 50th anniversary in the 2010. Activities will honor the leaders—board of education members, presidents, faculty, staff, alumni, and community—whose vision made our college grow.

Living in Eastern Oregon

The communities of northeastern Oregon offer many cultural, historical, and recreational attractions. Pendleton hosts two symphonies that attract musicians from throughout the region. Hermiston's Desert Arts Council sponsors numerous concerts and cultural events. The Arts Center of Pendleton, the first regional arts center in eastern Oregon, offers gallery exhibits and emphasizes arts education. The Tamástslikt Cultural Institute of the Confederated Tribes of the Umatilla Indian Reservation highlights a living history exhibit of regional Native American customs and culture. County museums preserve and present local histories, and the National Historic Oregon Trail Interpretive Center near Baker City commemorates our place on the Oregon Trail.

Many communities in the six counties served by the college have unique seasonal festivals and historic architecture that reflect the spirit and history of the region. The world-famous Pendleton Round-Up celebrates the heritage of the West every September with rodeo competitions, community events, and pageants. This cowboy sport is also enjoyed at county fairs and other festivals throughout the region. The Hermiston Watermelon Festival, Baker City's Miners' Jubilee, and Milton-Freewater's Muddy Frogwater Festival are a few of the many popular events that showcase local products and community pride.

Bordered by the Blue Mountains, the Columbia River, and rolling crop land, our district abounds in recreational attractions. The local area offers an abundance of year-round recreational sites, including state and national parks. The Umatilla National Forest, under the jurisdiction of the U.S. Forest Service, provides more than a million acres of wilderness recreation opportunities. Skiing, snowboarding, fishing, hiking, rafting, and hunting are outdoor activities available to BMCC students, local residents, and visitors.

Eastern Oregon has four distinct seasons with a very livable climate. Sun-filled summers see temperatures ranging from 73 to over 100 degrees, while winters average 33 degrees. Humidity is low, averaging 45 to 50 percent. Our dry climate produces about 13 inches of rain each year. We occasionally have snow for winter fun.

Our Locations

Students have access to the following services at any of the BMCC locations:

- ✓Degree-planning assistance
 - ✓Courses, workshops, and other educational offerings
 - ✓Textbook purchases
 - ✓Guidance in obtaining financial assistance and in applying for scholarships and grants
 - ✓Placement assessments in math, writing, reading, and computer literacy
 - ✓Assistance with disability accommodation
 - ✓Academic advising by either visiting or calling the center
- Each location offers additional unique services, which are highlighted below.

BMCC Pendleton

2411 N.W. Carden Avenue
Pendleton, OR 97801
Phone: 541-276-1260
Fax: 541-278-5871
Email: getinfo@bluecc.edu

Blue Mountain Community College's main campus is located on a scenic 160-acre hilltop site overlooking Pendleton, a city of 16,600 residents. We are located 200 miles east of Portland and nearly equidistant from Seattle, Spokane, and Boise.

The main campus houses both cultural and recreational venues. The Betty Feves Memorial Gallery, located in Pioneer Hall, exhibits a wide variety of art and functions as an educational tool to encourage creativity and to foster an appreciation of art. Pioneer Hall Theater hosts a variety of activities including concerts, plays, lectures, and workshops. Campus recreational facilities center around the McCrae Activity Center, which houses handball and racquetball courts, a free weight room, a total fitness room, a gymnasium, and a 25-meter heated swimming pool.

Varieties of co-curricular activities augment the education offered on campus and are an important component of the Blue Mountain Community College experience. For the serious athlete, BMCC has a well-rounded athletic program for both men and women. The college fields intercollegiate teams in basketball, volleyball, softball, baseball, and rodeo. The main campus houses the Associated Student Government (ASG) and a variety of student clubs, which provide educational, recreational, social, and leadership opportunities for interested students.

Tours of the BMCC Pendleton campus may be arranged by contacting the outreach coordinator at 541-278-5936 or by emailing: getinfo@bluecc.edu.

BMCC Baker County

3275 Baker Street
Baker City, OR 97814
Phone: 541-523-9127
Fax: 541-523-9128
Email: bmccbaker@bluecc.edu

With two sites in Baker City, on Baker Street and in the National Guard Armory, BMCC Baker County offers a variety of:

- ✓ College credit classes
- ✓ Job skills workshops
- ✓ College preparatory classes including adult basic education, adult high school diploma and credit recovery, general educational development (GED) preparation, and English as a second language (ESL)
- ✓ Customized training for business and industry
- ✓ Emergency medical training, first aid, and certain occupational certifications
- ✓ Personal enrichment courses

Students have the opportunity to take classes at the local sites, or they may choose to take advantage of the distance education programs, which allow students to complete their classes using the Internet, videotapes, guided instruction, interactive television (ITV), or workbooks. Using a combination of on-site and distance education, students may complete their A.A.O.T. degree at the Baker County center.

The Small Business Development Center also has a representative at BMCC Baker County. For additional information or to schedule a tour, please contact the BMCC Baker County office.

BMCC North Morrow County

300 N.E. Front Street
Boardman, OR 97818
Phone: 541-481-2099
Fax: 541-481-3990
Email: bmccnorthmorrow@bluecc.edu

BMCC North Morrow County serves the westernmost region of the college district. The center offers a variety of:

- ✓ Job skills workshops
- ✓ College preparatory classes, including adult basic education, adult high school diploma and credit recovery, GED preparation, and ESL courses
- ✓ Customized training for business and industry

Students have the opportunity to take classes at the local site, or they may choose to take advantage of the distance education classes, which allow students to complete their classes using the Internet, videotapes, guided instruction, or ITV. Using a combination of on-site and distance education, students may complete their A.A.O.T. degree at the Boardman center. Classes are offered at BMCC Boardman during both day and evening hours.

BMCC Hermiston

980 S.E. Columbia Drive
Hermiston, OR 97838
Phone: 541-567-1800
Fax: 541-567-1020
Email: bmcchermiston@bluecc.edu

BMCC Hermiston, the largest of the centers, serves western Umatilla County and North Morrow County. Offerings include:

- ✓ College credit classes
- ✓ Job skills workshops
- ✓ College preparatory classes, including adult basic education, adult high school diploma and credit recovery, and English as a second language (ESL) courses
- ✓ GED preparation by appointment and at regularly scheduled times
- ✓ Customized training for business and industry
- ✓ Emergency medical training, first aid, and occupational certifications
- ✓ Personal enrichment courses
- ✓ Citizenship classes
- ✓ Welding classes
- ✓ Computer-aided drafting (CAD) classes

Although students have the opportunity to take advantage of the distance education classes using the Internet, videotapes, guided instruction, or ITV, students at BMCC-Hermiston may complete their A.A.O.T. through courses offered entirely at the center. A multi-year pattern of courses allows students to complete their associate's degree as part-time students. Some classes are offered during daytime hours, and some are scheduled as evening classes to accommodate working students with a variety of schedules.

The Oregon JOBS program (a welfare-reform contract with the Oregon Community Human Services Department) and the Small Business Development Center have representatives housed at the Hermiston center. For additional information or to schedule a tour, please contact the BMCC Hermiston office.

BMCC South Morrow County

P.O. Box 21
Ione, OR 97843
Phone: 541-422-7040
Fax: 541-422-7015
Email: bmccsouthmorrow@bluecc.edu

BMCC South Morrow County, located in Heppner, provides support services for students in the Heppner, Lexington, and Ione areas to access the many courses offered at BMCC through the Internet, videotapes, guided instruction, or ITV. Enrichment and job training courses are also available. For additional information or assistance, please contact the BMCC South Morrow County office.

BMCC Milton-Freewater

311 N. Columbia
Milton-Freewater, OR 97862
Phone: 541-938-4082
Fax: 541-938-3763
Email: bmccmiltonfreewater@bluecc.edu

This growing center, located five miles south of the Oregon-Washington state line on State Highway 11, offers classes on-site as well as distance education, which allows students to complete their classes using the Internet, videotapes, guided instruction, or ITV. By combining on-site and distance courses, students may complete a variety of degrees and certificates. In addition, Milton-Freewater offers:

- ✓ Job skills workshops
- ✓ College preparatory classes, including adult basic education, adult high school diploma and credit recovery, GED preparation, and ESL courses
- ✓ Customized training for business and industry
- ✓ Personal enrichment courses
- ✓ GED testing available on-site by appointment and at regularly scheduled times.
- ✓ Citizenship classes
- ✓ Welding classes
- ✓ CAD classes

The Oregon JOBS program is available at Milton-Freewater. For additional information or to schedule a tour, please contact the BMCC Milton-Freewater office.

BMCC Grant County

835-B S. Canyon Boulevard
John Day, OR 97845
Phone: 541-575-1550
Fax: 541-575-2920
Email: getinfo@bluecc.edu

BMCC Grant County focuses on building relationships with community organizations, local businesses, and area schools to serve the citizens of Grant County. This site provides support services for students to access the many courses offered at BMCC via Internet, videotapes, guided instruction, or ITV. On-site college credit courses, community enrichment, and job training courses including certified nursing assistant (CNA) training are available. Adult basic education offerings in Grant County include adult basic education, adult high school diploma and credit recovery, and GED preparation. For additional information or to schedule a tour, please contact the BMCC Grant County office.

BMCC Wallowa County

107 S.W. 1st
Enterprise, OR 97828
Phone: 541-426-4109
Fax: 541-426-6059
Email: getinfo@bluecc.edu

Established in 1989 and located in Enterprise, BMCC Wallowa County provides learning opportunities to the residents of Wallowa county, including:

- ✓ College credit classes
- ✓ Job skills workshops
- ✓ College preparatory classes including adult basic education, adult high school diploma and credit recovery, GED preparation, and ESL courses
- ✓ Customized training for business and industry
- ✓ Personal enrichment courses

Students have the opportunity to take classes at the local site, or they may choose to take advantage of distance education programs, which allow students to complete their classes using the Internet, videotapes, guided instruction, or ITV. For additional information or assistance, please contact the BMCC Wallowa County office.

Distance Education

What is Distance Education?

Distance education is any kind of learning in which students and the instructor are separated by time and/or place. It can be delivered using various methods of technologies, including:

Online Courses: Course offerings are provided over the Internet, with instructors located at either BMCC or another Oregon community college (host/provider). Tests are conducted either online or at a BMCC location.

Telecourses: Classes are presented primarily on DVD. Students use textbooks and interact with the instructor either online or through postal services. Tests usually are proctored at a BMCC location.

Interactive Video Conferencing (ITV): Classes originate from another site but are real in time and place. Classes are offered through interactive television or Web-based software **Interactive Video Computer (IVC)**. Students may meet at a designated BMCC site and interact with the instructor and students at other sites.

Guided Instruction: Courses are taught through the mail only, with materials presented on paper in the form of study guides and textbooks (no videotapes). Students contact the instructor in writing or through telephone discussions.

Who Benefits From Distance Education?

The time-bound student, whose job or education schedule conflicts with the times when classes are offered on campus.

The distance-bound student, who lives far from where classes are offered.

The home-bound student, who cannot leave home for personal reasons.

Those whose **work schedules** prevent them from finding blocks of time to participate in classes.

Those who seek to advance themselves in their current career or to prepare for a new career.

Who Should Take Distance Ed Classes?

- Self-motivated learners
- Time- or place-bound learners
- Technically astute learners

Registering for Distance Education Classes:

Student services and financial assistance information for distance education students—such as admissions, enrollment, registration, advising, book purchases, and

payment—are the same as for any other classes offered at BMCC, noted elsewhere in this catalog. Please see the Getting Started section on **page 4** for more information. For registration information and a list of courses, go to www.bluecc.edu.

Financial Assistance for Distance Education:

Online students may be eligible to receive financial assistance. Complete the Free Application for Federal Student Aid (FAFSA) form, available online at www.fafsa.ed.gov. BMCC's federal school code is 003186. Check page 22 of this catalog or our Website for more financial assistance information.

Paying for Distance Education Classes:

Blue Mountain Community College's distance education classes are assessed at the current tuition and fees listed in the Schedule of Classes published each term and online at www.bluecc.edu. ***There is an additional distance education class fee for each class.***

Purchasing Distance Education Textbooks:

Students can order books online with a credit card at www.bookstore.bluecc.edu, or students can call the bookstore at 541-278-5733 or send a fax to 541-278-5842. Students taking an online course provided by another Oregon community college (host/provider) may order books by contacting the BMCC bookstore. Links to host/provider colleges can be found on the Distance Education page of our Website; click on OCCDL.

Library Services:

Many library services and electronic databases are available online to all students, whether on or off campus. Go to www.bluecc.edu/library for information on library services

Technical Help and Support: *

The Office of Distance Education is located on the Pendleton campus in Pioneer Hall, Room 154. The email address is Distance_Ed@bluecc.edu.

Additional information and services are on the Distance Education page of our Website. There students will find tutorials, frequently asked questions, self-assessment tests, and the hardware and software requirements for taking online classes. Students can view current term class information on the distance education Webpage.

**If you are enrolled in another Oregon community college course, you must contact the technical support services at that community college. You can find links on the Distance Education page of our Website; click on OCCDL.*



Student Information

Students' Rights and Responsibilities

At Blue Mountain Community College, we support your right to actively question and seek constructive change in the college environment. We encourage you to express your views, opinions, and concerns in and around BMCC. Our goal is to promote diverse and critical thinking—it's an important part of your college education. However, any kind of conduct that restrains either the freedom of expression or the freedom of movement of others who may not agree, or that is disruptive to college operations in any way, is not acceptable. As a learning community, all of us have an equal right to our own views, and BMCC is committed to keeping the college a safe place for all students, staff, and community members.

The Student Rights, Responsibilities, and Code of Conduct document outlines the expectations we have of you as you participate on campus and in college activities. If you'd like to review or receive a complete copy of the *Student Rights,*

Responsibilities, and Code of Conduct document, contact the Service Center or the Associated Student Government, or pick up a copy at the reserve desk in the college library. This statement is also online at www.bluecc.edu.

Student Right-to-Know Information

In compliance with the Student Right-to-Know and Campus Security Act of 1990 (Public Law 101-542), Blue Mountain Community College discloses completion/graduation rates and transfer rates to all current and prospective students. Rates are based on fall-term enrollment of full-time (12 term credits), first-time, and degree- or certificate-seeking undergraduates. Students are counted as graduates or as transfer-outs if they graduated or transferred within 150 percent of the normal time for completion or graduation. Rates do not include part-time credit students, students who have attended college elsewhere before attending BMCC, students who began their studies in a term other than fall, or students not seeking degrees. For further information, contact the Office of Enrollment Management at 541-278-5759.

Statement of Non-Discrimination and Grievance Procedure

It is the policy of the Blue Mountain Community College Board of Education and School District that there will be no discrimination or harassment on the grounds of race, color, sex, marital status, religion, national origin, age, or disability in any educational programs, activities, or employment. If you have questions about equal opportunity and nondiscrimination, contact the Executive Assistant to the President at BMCC, PO Box 100, 2411 NW Carden, Room P-103 in Pioneer Hall, Phone 541-278-5951 or TDD 541-278-2174.

The college has adopted a grievance procedure providing for prompt and equitable resolution of student and employee complaints alleging any discrimination based on sex or disability. To view this procedure, go to www.bluecc.edu, Human Resources.



Drug and Alcohol Statement

Blue Mountain Community College is legally required and morally committed to the prevention of illicit drug use and abuse of alcohol by both students and employees.

The college reinforces this message through various publications that explain our policy and procedures on this issue, including the *Students Rights, Responsibilities, and Code of Conduct* document, the Student Handbook, and all employee handbooks. These items are available to students through the Office of Enrollment Management and to employees via the StaffWeb or the Office of Human Resources.

Family Educational Rights and Privacy Act

The college abides by and honors all state and federal laws pertaining to the privacy and confidentiality of your directory information and academic records. If you choose to do so, you have the right to restrict access to specific information.

The Family Educational Rights and Privacy Act of 1974 (FERPA) grants you, the student, certain rights, privileges, and protections relative to individually identifiable student educational records that are maintained by BMCC. Specifically:

- FERPA allows colleges to disclose your directory information without consent. If you do not want this information released, you must notify the nearest BMCC office and complete and sign a non-release form.
- Directory information includes students' full name, address, email address, telephone number, date and place of birth, field of study, class level, dates of attendance and degrees, honors and awards, athletic participation (the height and weight of team members) and the most recent previous educational institution attended.
- Students have the right to inspect and review their own individual educational records. Students have the right to challenge information contained in individually identifiable educational records.
- Students' educational records (with the exception of directory information) will be released to third parties only with the written consent of the student.

For more information or to exercise your rights contact the Associate Vice President of Enrollment Management at 541-278-5774.

General Information

Admission Policies

Blue Mountain Community College has an open-door admission policy. In general, you may enroll provided you:

- Are eighteen years of age or older, **or**
- Are legally emancipated (with documentation), **or**
- Have graduated from an accredited high school, **or**
- Have completed a general educational development (GED) certificate or an adult high school diploma, **and**
- Have the ability to benefit from instruction.

If you are under eighteen years of age and no longer attending high school, have not graduated from an accredited high school or completed a GED, and wish to attend BMCC you may enroll by providing the following:

- A letter from a high school administrator stating that the you have been released from compulsory school attendance under the provisions outlined in ORS 339.030, **and**
- An assessment by a BMCC advisor regarding the your ability to benefit from the instruction desired, **and**
- Your parent's signature on any enrollment or registration document that obligates you, the student, financially, **and**
- An acknowledgement that you will be in a classroom situation with other adults and without the same protections and rules of the K-12 system.

If you are under the age of eighteen and still attending high school and wish to take a class or two for personal enrichment or for credit at your high school you may do so with parental sign-off on the financial obligations incurred. If you wish to take classes for high school credit, please check with your high school administration to ensure that the credits taken will transfer in the way you intend.

If you were home-schooled, you are welcome to enroll in classes and attend BMCC under the same conditions as other students. If you or your family members have questions about admission, please contact the Service Center in Pendleton at 541-278-5759.

Oregon Residency Requirements

Your residency status determines your tuition rate for your classes. The college has three tuition schedules: in-state, out-of-state, and international. For purposes of determining tuition rates and receiving state reimbursement, BMCC is required by law to establish a residency policy.

You may petition for residency if at least one of the in-state criteria is met **and** you provide at least two of the documents listed on this page. Petitions must be made in writing. Your requests should be submitted, along with at least two of the documents listed below to the admissions office for approval.

In-State Criteria (student must meet at least one):

- ✓ The student has maintained a permanent address in Oregon for at least 90 continuous days prior to the first day of the term.
- ✓ The student is a resident of Washington, Idaho, Nevada, Montana, or California.
- ✓ The student or a member of the immediate family holds title to or is otherwise purchasing property that is claimed as a permanent Oregon residence.
- ✓ The student or parents of a dependent student filed an income tax statement with the Oregon Department of Revenue for the most recent reporting year.
- ✓ The student is a veteran who established residency in Oregon within one year of separation or discharge from the service.
- ✓ The student is a dependent of parents or legal guardians who have established permanent residency within Oregon.

Documents (student must provide at least two):

- ✓ An Oregon hunting or fishing license that was issued at least ninety days before the beginning of the term.
- ✓ A copy of deed of title, mortgage agreement, or recent county property tax statement indicating ownership or purchase by the student or the immediate family. If ownership is by anyone other than the student, a document verifying the relationship between the student and an owner must be presented.
- ✓ A current Oregon voter precinct card.
- ✓ A copy of a signed Oregon income tax statement filed during the latest reporting year or payroll records from an Oregon firm indicating ninety continuous days of residency in Oregon.
- ✓ A copy of an official Oregon high school transcript or GED scores earned in the state of Oregon.
- ✓ A copy of a valid Oregon driver's license (front and back of license).

Out-of-State Criteria

With the exceptions listed above, you must pay out-of-state tuition if you list your permanent address as being outside of Oregon or if you list your parents' address as outside Oregon and you are claimed as a dependent by your parents on their income tax report. If you are an Alaska resident and you wish to receive the Alaska Permanent Fund Dividend while attending BMCC, you must maintain your out-of-state residency status.

International Criteria

If you are a citizen of another country and are attending BMCC on a student visa, you will pay the international tuition rate.

Admission Procedures

Degree and Certificate Programs

If you are seeking a degree or certificate, you are required to:

- Complete and submit a BMCC Application for Admission to the BMCC Service Center or a local BMCC location OR you may create a student account by logging into the Student WolfWeb from BMCC's Website.
- If you have taken courses at another college or university, request your OFFICIAL transcripts and have them sent to the BMCC Service Center. Be sure to also complete and submit a *Transcript Evaluation Request Form* so that we may evaluate credits earned at prior institutions toward your stated degree intent at BMCC.
- Complete the BMCC placement assessment. Transfer students who have not successfully completed a college- or university-level math and writing course will be asked to take the BMCC placement assessment.

Transfer Students:

A *Transcript Evaluation Request Form* must be submitted upon entry to BMCC. The credits you earned and completed with a grade of "D" or higher will be evaluated. The Office of the Registrar will send written notification about which courses will be accepted at BMCC to meet the requirements of your intended degree.

Other college courses that you have completed with a grade of "D" or higher will be included in the cumulative grade point average (GPA) computation if they fulfill requirements for graduation, including core courses and any appropriate electives. Courses not used will not be counted in the cumulative GPA. Courses accepted towards degree requirements will not be listed on your BMCC transcript, however, a note will appear at the top of your transcript regarding a cumulative number of credits accepted for that degree.

Limited Entry Programs:

BMCC offers a number of limited-entry programs. Each program has special admissions requirements that must be met before you can be admitted. General admission to BMCC does not guarantee acceptance into these programs. The admission requirements may change annually depending upon Oregon state regulations and BMCC policies. For the most current admissions policy information and deadlines, please contact admissions or the academic department, or consult BMCC's Website.

International Admissions

Blue Mountain Community College welcomes international students and provides an affordable education in a safe, comfortable environment. To be considered for admission as an international student, you must:

1. Complete BMCC's International Application for Admission packet.
2. Pay a \$25 (U.S.) non-refundable application fee
3. Submit an official TOEFL score report (minimum 213 computer-based score, 550 paper-based, or 97 internet-based).

Additional requirements to be met for admission (to obtain an I-20 visa) include:

- ✓ Proof of adequate funds for the student's studies;
- ✓ A complete set of documents for all of the student's previous and current studies, and
- ✓ Proof of health insurance;

International students must be enrolled full-time (12 or more credits) and successfully complete 12 or more credits each term to remain in good standing with the U.S. Citizenship and Immigration Services (USCIS).

For more information, or to receive an international student application packet, please contact admissions; email getinfo@bluecc.edu; or visit the International Student Admissions page on BMCC's Website. You will be notified by mail after all of the application materials are received and verified.

Non-Degree Admissions

If you wish to enroll for courses at BMCC but not to obtain a degree or certificate you are required either to:

- ✓ create and use an on-line Student WolfWeb account to enroll; or
- ✓ submit a completed BMCC Registration form to your local BMCC site.

Every student, whether degree-seeking or not, who intends to take a credited math or writing course is required to take the math or writing placement test. Placement in these courses is mandatory. If you have completed a math or writing course, you will need to submit either an unofficial grade transcript or placement assessment from your prior college (test must have been taken within the last two academic years). Once you have submitted your documentation to our Testing Center a waiver will be applied to your student account within two business days. Note: You must have passed your math or writing course with a grade of "C" or higher. If you have been out of school for two or more years, you must take the math or writing placement assessment.

Placement Assessment

Placement assessment is required if you intend to take a math or writing course and have not already taken a math or writing course at a college or university. In addition, degree-seeking students must also complete placement assessments for reading and computer literacy. You are encouraged to review the topics covered in the placement assessment. Our testing center can recommend a variety of study tools. BMCC uses self-paced, computerized tests designed to determine your level of academic ability in each of these subject areas. The scores are used to assist you and your advisor in placing you in the correct course.

If you have taken either a math or writing course from another college or university, you will need to provide the Advising and Testing Center with a copy of your unofficial grade transcript to determine proper placement in math and or writing courses at BMCC. Note: You must have passed your math or writing course with a grade of "C" or higher.

All BMCC locations administer placement assessments. Dates and times for testing are posted on the college Website, or you can call 541-278-5931. There is no cost to you for this service.

You may take the placement assessment in whole or in part up to three times (the initial test and two repeated tests), if you wish. The testing center uploads test scores regularly to provide the most current information to your advisor when helping you plan an appropriate course schedule. BMCC does not use placement assessment scores to determine admittance to the college.

If you disagree with the placement recommendation in reading or writing, you may be referred to the appropriate academic department for further placement advising and possible further testing. Should you disagree with your math placement after retesting one time, you may request to take a challenge test.

To request a placement assessment with accommodations due to a disability please contact the assistant director of admissions and advising at 541-278-5958.

Computer Literacy Requirement

With the goal of ensuring that each degree-seeking student has the necessary college-level computer literacy, BMCC includes computer literacy as a component of the placement assessment process. Unlike the other placement assessments, the computer literacy component allows you some options. If you take the computer literacy placement assessment and score in the passing range, the college will waive your computer literacy course requirement for graduation. If you score in the excellent range, the placement will serve as a "credit by challenge examination" and you will receive credit for CS 120 if you choose to pay half tuition. If you score below passing, however, a computer literacy course will become a requirement for graduation; should that occur, the college strongly recommends that you take the computer literacy course early in your BMCC coursework to ensure your success at BMCC.

A final option is not to take the computer literacy placement assessment. This option applies if you plan to take one of the computer literacy courses because it interests you or because it is a requirement of the degree and you do not wish to seek the waiver or credit described above.. The general computer literacy course is CS 120, but if you are a business technologies, education, or agriculture student, you will substitute BA 131, ED 235, and AGR 111 respectively to meet program requirements.

Adult Basic Education (ABE) and General Educational Development (GED) Admissions

These programs are open to non-high school graduates who are at least sixteen years of age and not enrolled in high school. Students who are sixteen and seventeen years of age must provide the college with a release from the high school district in which they reside according to O.R.S. 339.030. For more information, contact the Department of College Preparatory Programs at 541-278-5795.

Registration Information

If you are a certificate or degree-seeking student, you must be cleared to register through your academic advisor in order to register online using the Student WolfWeb link found on BMCC's Website. If you do not have access to the Internet or if you need assistance in registering for courses, you may visit any BMCC location to register in-person.

You are encouraged to register before the first day of classes each term. You may add courses up through the end of the fifth day of the term or the equivalent for classes that begin after the first week of the term. For more information on registration dates and timelines, see the calendar found in this catalog or visit our Website.

For special registration assistance due to a disability, please contact the assistant director of admissions and advising at 541-278-5958.

Degree-Seeking Students

If you are a new or returning degree-seeking student, you will need to make an advising appointment with an academic advisor. To make an appointment, call the Advising and Testing Center in Pendleton at 541-278-5931 or contact the BMCC location closest to you. You may also contact your advisor or academic department directly to set up an advising appointment.

The advising process will include information regarding registration for classes.

Non-Degree Seeking Students

If you wish to enroll in courses at BMCC but not to obtain a degree or certificate, you may register online using the Student WolfWeb link found on BMCC's Website. If you do not have access to the Internet or need assistance in registering for courses you may visit any BMCC location to register in-person. You are considered to be registered when the college receives your completed registration unless the college notifies you that the courses for which you registered for are full or cancelled or that you have been placed on a waitlist.

Course Numbers

Generally, courses with letter prefixes apply toward degrees and certificates, and courses with 100 and 200 numbers are college transfer courses; those numbered 200 to 299 are considered sophomore-level courses. Be sure to check the degree requirements for the certificate or degree you are seeking to ensure that the course you are taking will be counted.

Credits

In order to earn an associate's degree in two years, you should enroll for an average of 16 college-level credits in fall, winter, and spring terms. If college preparatory courses are required, the number of credits each term would increase accordingly. Curriculum and program requirements described in this catalog provide more information on the program or degree of your choice.

If you are participating in intercollegiate athletics, you must complete and pass at least 12 credit hours each term for eligibility purposes. You are encouraged to visit with BMCC coaches for detailed eligibility requirements.

Attendance

Blue Mountain Community College believes that it is the student's obligation to attend and participate in classes and that there is a direct correlation between participative attendance in a course and successful completion. Individual courses may have their own attendance policies. The college has instituted an administrative drop process for the first five days of class each term, which provides a 100% refund for each class dropped. If you are not in attendance the first day of class, someone from the academic department may contact you to inquire whether you plan to attend the rest of the term. The administrative drop process is not guaranteed. If you are not intending to continue in classes, you must not assume that you will be automatically dropped for non-attendance. To drop a course or courses, you can go online or contact the college for assistance. You will be responsible for payment of any and all courses you have not dropped as of the end of the 100% refund period.

Auditing Classes

You may audit a course at a reduced tuition rate. If an audit is desired, you must make this selection at the time of registration, and the status cannot be changed to receive a grade after the 100% refund period. The audit option is not available for "late add" either as a new selection or a status change. If you are auditing a course, you can attend class and are not required to participate fully in the class activities (e.g., taking tests or doing homework). Classes taken under audit status do not count as credits attempted in financial aid award calculations, and the AU (audit) status does not count in calculating GPAs. The audit indicator "AU" indicates a registration status, not an evaluation.

Drop/Withdrawing from Classes

Definitions:

Drop: When you remove a course from your schedule before the end of the 100% refund period for that course. If you drop a course or courses from your schedule, it/they will not show up on your grade transcript. **Note:** Courses that are less than a full term in length have different refund periods indicated on your schedule as "last date to drop and pay".

Withdraw: When you remove a course from your schedule after the 100% refund period for that course. If you withdraw from a course or courses it/they will show up on your grade transcript with a status of "W" to indicate that you withdrew from that course. **Note:** Courses that are less than a full term in length have different withdrawal deadline dates.

To drop or withdraw from a course, either complete an Add/Drop/Withdraw form and submit it to a BMCC Center for processing or log in to your student account on the Student Wolfweb from BMCC's Website.

If you leave BMCC without following the withdrawal procedures described above, you are responsible for the final grades you receive; they will appear on your transcript.

Withdrawal from College

If you find you can no longer attend classes, you should officially withdraw from school. Before doing so, please be sure to work with your advisor to determine whether other options are available to you. The last day to withdraw from classes without receiving a grade is listed on the academic calendar on the inside front cover of this catalog. **Note:** Courses that are less than a full term in length have different withdrawal deadline dates.

If you are receiving financial aid, refer to the Financial Assistance section of the catalog for further information regarding the effects of completely withdrawing from all of your courses.

NOTE: A student who is registered is considered to be in attendance. **Non-attendance or non-payment does not constitute official withdrawal, nor does it release you from the obligation to pay for your course or courses.**

Withdrawal for Military Duty

The following guidelines apply when a veteran, Reserve, or National Guard student is called to active duty for military purposes during the term:

- You may drop courses and receive a full tuition and fee refund.
- You may, at your discretion, elect to complete courses after making special arrangements with your instructor(s) to create an incomplete contract allowing reasonable time to complete the academic work required.

Please contact the Service Center in Pendleton for further information at 541-278-5759, or send an email to: getinfo@bluecc.edu. If you are receiving financial aid you need to refer to the Financial Assistance section of the catalog for further information regarding withdrawals.

Academic Information Grading System

The quality of your work is measured by a system of grades and by computed grade-point averages. All assigned courses, regardless of curriculum, are included when determining a cumulative grade-point average while attending BMCC.

The grading system consists of the following:

Grade		Points
A	Superior	4
B	Above Average	3
C	Average	2
D	Inferior	1
F	Failing	0
INC	Incomplete	0
P	Pass	0
NP	No Pass	0
R	Course Repeated	0
W	Withdrawal	0

Only grades of A, B, C, D, and F are considered in the computation of grade point averages. All other grades will be disregarded in the calculation of your GPA; however, other grade marks will affect financial aid and athletic eligibility.

GRADE POINT AVERAGE (GPA)

Your grade point average (GPA) is calculated as follows: take the number of points from the table above for each grade that you received and multiply it by the number of credits for that course; then repeat the process for each course in which you received a grade of A, B, C, D, or F. Add all of the results together and then divide by the total credit hours in which grades A, B, C, D, or F were received. Note: If a course is repeated, only the most recent grade is used in computing the GPA unless the course is designated as repeatable in the Course Descriptions section of this catalog.

INC (Incomplete Grade)

Your instructor(s) may assign an incomplete grade when the quality of your completed work is satisfactory but the course has not been completed for reasons acceptable to the instructor. At least sixty percent (60%) of your course work must be completed for an incomplete grade to be given. An incomplete grade must be made up within a maximum of one calendar year from the date that the incomplete appears on the grade report; however, the student and instructor may choose a shorter time in which to complete the course work. Incomplete Grade Contracts are submitted at the time grades are submitted and do not require the student's signature. The Registrar's Office will maintain and monitor INC contracts for the college. If the instructor does not return your completed INC contact to the Registrar's Office providing your final grade earned by the contract deadline date, the alternative grade indicated on the contract will automatically be entered into your permanent record. It is your responsibility to complete the work agreed upon and the instructor's responsibility to submit the final grade earned in a timely manner to the Registrar's Office.

P/NP (Pass/No Pass)

If you wish to use the P/NP option you must:

- Elect to do so by the end of the fourth week of the term. Once you declare the P/NP grading option, no changes in grading can be made.
- Submit an application for the P/NP grading option to the Registrar's Office. Before submitting this form to the Registrar's Office, you must first collect the signature of the instructor of the course for which you are exercising this option.

You may apply a maximum of 12 program or elective credits with a grade of P toward a degree at BMCC. This number would include pass grades earned in regular BMCC classes and those earned from another college or university. This number does not include pass grades earned in course work with obligatory pass grades or advanced placement credits transcribed as pass.

The P/NP option is not available in courses being repeated by the student, in courses required for a degree, or in courses in the core area required for an associate of arts degree (pass grades would be accepted in advanced placement test credit.).

The P grade denotes a level of accomplishment of C or better.

Pass grades from other institutions will be examined on an

individual basis. If the registrar determines that the course meets or exceeds BMCC requirements, then credit may be granted.

If you are planning to transfer to a four-year institution, you should determine the policy of that school before electing the P/NP option at BMCC.

When computing credits earned and GPA, the Registrar's Office treats the P/NP credits as follows:

- The pass credits will be transcribed as credits earned and will not be computed in the grade point average.
- The no pass credits will show on the transcript as credits attempted and will not be computed in the grade point average.

R (Course Repeated)

Assigned when you have repeated a course. If you repeat a course, the college will count the grade received for your most recent attempt. All other attempts at the course where a grade of A, B, C, D, or F was given will be changed to a grade of "R" on your transcript.

W (Withdrawal)

A grade of W indicates that you followed the formal withdrawal procedure and withdrew from the course during the term. This grade is not used in computing GPA.

A W grade is not punitive. It simply indicates that you withdrew from the course and therefore received no grade.

Enrollment Status

In addition to the above grades, other enrollment-status indicators may be entered on your grade report or transcript. These include AU (audit), CIP (course in progress), H (adult high school diploma variable-hour courses), and MSG (missing grade).

AU (Audit)

This is NOT a grade. It is an enrollment status and must be declared at the time of registration for the course. (See page 16 for more information.)

CIP (Course in Progress)

CIP is an enrollment status to be used when a course is scheduled to continue from one academic term into the next. The CIP is not a terminal grade but is, rather, a state of progress to be used until the ending date of the class. At the time a course is scheduled to conclude, the CIP status will be replaced by a grade.

H (Adult High School Diploma variable hour courses)

H will be used in the adult high school diploma system to indicate an Adult High School Diploma Variable-Hour course that the student has not finished in a particular term.

MSG (Missing Grade)

A grade designation of MSG, or a blank, indicates that the course grade is missing for some reason. Please contact your instructor to ensure that the grade was submitted to the Office of Enrollment Management.

Grade Changes

College procedures allow for grade changes up to one year after the end of the term in which the course or courses were taken. Once a grade has been assigned other than an INC, the only acceptable reason for grade changes is instructor or college error. The instructor/student relationship in a given class concludes at the end of the term with the assignment of a grade unless the student receives a grade of INC to allow for the submission of late course work. If you cannot complete all of the course work before the end of the term, you should work with the instructor before the term ends to request a grade of INC. Otherwise, the only way that an instructor can agree to change your grade is for you to submit a grade appeal (see the section on grade appeals).

Grade Appeal Process

The responsibility for assigning grades rests with the individual instructor, who uses his or her best judgment in accordance with what is deemed fair, given the requirements of the course and the work performed by the student.

If you believe that you have been awarded an inappropriate grade by an instructor, you may fill out a grade appeal form and submit it to the Office of Instruction. This will initiate the grade appeal process as outlined in the Student's Rights and Responsibilities Handbook.

Grade Point Average (GPA) Renewal Policy

Students who have previously attended BMCC and have earned poor grades often feel discouraged about trying again. In order to encourage these students, Blue Mountain Community College has established a GPA renewal policy.

If you have returned to BMCC after an absence of at least two years and have subsequently passed two academic quarters of work of at least 12 credit hours each quarter with a 2.00 GPA or better, you may petition the registrar to implement the GPA renewal policy. If the petition is accepted, grades for the term chosen, and for all prior terms, will be changed to no credit (NC). All courses previously taken will remain on the transcript, but the grade point average will be adjusted. A notation will appear on your transcript indicating that the GPA renewal policy was implemented. All courses included in the GPA renewal policy will still be counted as attempted for the purposes of federal financial aid eligibility.

This policy may be used only once. You must be enrolled in at least one credit hour at the time that the policy is implemented. Any courses taken at another college and transferred to BMCC are not subject to the provisions of this policy and are not included in this policy.

Final Examinations

Final examinations are given at the close of each term. You are required to take final examinations at the regularly scheduled time. Final examination schedules are available online or on the academic calendar found in this catalog. If circumstances warrant taking final examinations at another time, you must make prior arrangements with your instructor.

Academic Achievement Recognition

Blue Mountain Community College recognizes exceptional academic achievement of students at the end of each term and at graduation.

Honor Roll, Dean's List, and President's List

You may attain honor status each term by qualifying for the Honor Roll, the Dean's List, or the President's List. In all cases, you must have completed 12 or more BMCC credits during the term with grades of A, B, C, or D.

Only courses taken at BMCC count towards academic achievement. Only term GPAs, not cumulative GPAs, are counted for these recognitions.

Honor status includes:

- Honor Roll: term GPA of 3.00 to 3.39
- Dean's List: term GPA of 3.40 to 3.84
- President's List: term GPA of 3.85 or higher

Grades of P, NP, INC, and W do not count toward recognition of academic achievement.

Honors at Graduation

Students with exceptional academic qualifications may graduate from BMCC with honors or high honors designation. This designation appears on the graduate's transcript and diploma and applies to all of BMCC's degrees and certificates for academic, career, and technical programs. To qualify, you must have attended at least two terms and have earned at least 24 credit hours at BMCC.

Honors designations are:

- Honors: cumulative GPA of 3.40 to 3.84
- High Honors: cumulative GPA of 3.85 or higher

Only the courses used for graduation will be counted in the cumulative GPA calculation. The calculation is performed on all courses completed the term prior to your stated term of graduation.

Example 1: If the anticipated term of graduation is spring term 2009, your GPA will be calculated at the end of winter term 2009. If you meet one of the above referenced GPA requirements you qualify to walk in the spring commencement ceremony with an honors designation.

Example 2: If the anticipated term of graduation is summer term 2009, your spring-term 2009 grades would be used to calculate your GPA. Since the commencement ceremony occurs before spring-term grades are posted, you would not qualify to walk in the 2009 commencement ceremony with an honors designation.

If you plan to complete your requirements no later than fall 2009, you may walk in the spring 2009 graduation, but will not qualify to walk with either honors designation. If, however, you believe that you may qualify for honors designation by the end of summer 2009, you might consider walking in the 2010 commencement ceremony.

Academic Notification: Warning/ Probation/Suspension

If you are seeking a degree or certificate, your transcripts will be reviewed at the end of each term to determine your academic success and persistence. If you meet any of the following criteria, you will be placed on academic notification:

- Your term GPA falls below 2.00.
- Your cumulative GPA falls below 2.00.
- You do not successfully complete at least 50% of the credits you attempted during the term.

You will be notified in writing or by email by the student success advisor (SSA) if you are placed on academic warning, academic probation, level-two academic probation, or academic suspension.

ACADEMIC WARNING

Criteria: The first term your GPA falls below 2.00

Action: You will be referred to the SSA for guidance on academic resources and will be encouraged to enroll in HD100 or HD109.

ACADEMIC PROBATION

Criteria: Your cumulative GPA is below 2.0, and/or you do not successfully complete at least 50% of attempted credits for the term.

Action: You will be required to receive assistance through one or more of the following actions:

- (a) enroll in HD100 or HD109,
- (b) Be assigned a tutor to assist you in subject areas in which you are deficient as indicated by a grade of D or lower, or
- (c) Attend other skill-building workshops as determined by the SSA. The SSA or the assistant director of admissions and advising has the authority to waive one or more of these requirements.

LEVEL 2 ACADEMIC PROBATION

Criteria: Your cumulative GPA is below 2.0 for the second consecutive term, and/or you do not successfully complete at least 50% of attempted credits for the second consecutive term.

Action: You will be blocked from registering for classes until you have submitted an Academic Appeal form and have met with the SSA. You will be limited to taking no more than 10 credits during your next term of attendance unless you are able to provide documentation and or reasoning to support your request for full-time attendance.

ACADEMIC SUSPENSION

Criteria: You remain on level 2 probation for a second term or have a cumulative GPA of below 2.0 for three consecutive terms.

Action: The SSA will update your status in our system to academic suspension. While suspended, you may not register for classes or participate in student activities. You have the right to appeal your academic suspension to the assistant director for admissions and advising or designated staff by completing the Academic Suspension Appeal form. In the event the assistant director for admissions and advising rules the suspension valid, you will have the right to appeal with the vice president of enrollment management.

The assistant director for admissions and advising or his/her designee has discretionary power to work within these guidelines to bypass any step if warranted or to extend any step, as he/she deems appropriate.

Consecutive term means back-to-back terms of attendance. Examples:

- Spring 2008 and fall 2008 (based on non-attendance summer 2008)
- Fall 2008 and winter 2009
- Fall 2008 and spring 2009 (based on non-attendance winter 2009)

Non Traditional College Credit

The purpose of awarding credit for prior learning is to acknowledge and validate knowledge, skills, and competencies acquired by students through experience. With the exception of cooperative work experience (CWE) credits (see page 30), students receiving alternate credits are not eligible for state or federal aid for those credits.

The maximum credits that may be earned through a combination of credit by examination, advanced placement (AP), and military credit are no more than 25 percent of the credits needed for a certificate or degree.

Credit by Examination: To obtain credit for certain courses, you must be enrolled as a BMCC student taking at least one course for credit and satisfactorily pass a comprehensive examination or series of examinations. You may not obtain credit by examination for a course at a lower level than one in which you have already demonstrated competency. Some courses are not eligible for this program. If you wish to obtain credit in this manner, you must pay a fee in addition to any other tuition and fees that you may have paid in that term. The Office of Instruction, at 541-278-5969, has all forms and makes all arrangements for credit by examination. Students are limited to 15 credits by examination.

Advanced Placement (AP) Test: You may earn credit for certain courses by taking tests administered by the Advanced Placement (AP) program sponsored by the College Board. Below is a list of approved AP courses, AP scores and advanced placement action. AP credits are reflected on BMCC's transcripts with a grade of P.

To receive AP credit you must:

- Be enrolled at BMCC in at least one credit course
- Pay the fee (1/2 the regular tuition plus any fees that apply)
- Complete and return an advanced placement credit form to BMCC.

Please contact the Registrar's Office at 541-278-5759 or email getinfo@bluecc.edu for additional information.

Subject	AP Score	Advanced Placement Action
Art Art History Art Studio	4, 5 4, 5	ART 204, 205, 206: 9 credits ART 101: 3 credits
Biology	4, 5	BIO 101, 102, 103: 12 credits
Chemistry	3, 4, 5	CH 104, 105, 106: 15 credits
Computer Science A	4, 5	CS 161: 4 credits
Computer Science AB	3 4, 5	CS 161: 4 credits CS 161, 162: 8 credits
Economics Macro Economics Micro Economics	3, 4, 5 3, 4, 5	EC 202: 3 credits EC 201: 3 credits
English English Composition English Literature	3, 4, 5 3, 4, 5	WR 121: 3 credits ENG 104: 3 credits
Environmental Science	3, 4, 5	GS 142: 4 credits
Geography Human Geography	3	GEOG 103: 3 credits
Government - U.S.	4, 5	PS 201: 3 credits
History History - European History - U.S. History - World	3, 4, 5 3, 4, 5 3, 4, 5	HST 101, 102: 6 credits HST 201, 202: 6 credits HST 104, 105: 6 credits
Math Calculus AB	3 4, 5	MTH 251: 4 credits MTH 251, 252: 8 credits
Calculus BC	3 4, 5	MTH 251, 252: 8 credits MTH 251, 252, 253: 12 credits
Statistics	4, 5	MTH 243: 4 credits
Music Music Theory	4, 5	MUS 111, 112: 8 credits
Physics Physics B Physics C - Electricity & Magnetism Physics C - Mechanics	4, 5 4, 5 4, 5	PHY 201, 202, 203: 15 credits PHY 201: 4 credits PHY 201: 4 credits
Spanish Language	3, 4, 5	SPAN 101, 102, 103: 12 credits

Military Credit: Military credit will be evaluated according to American Council of Education guidelines. Typically, credit is considered only when it is equivalent to regular course offerings. Military credits are restricted to a maximum of 12 credits.

Transfer Credits

Transferring Credits to BMCC

If you wish to transfer credits to BMCC, you will need to complete a Transcript Evaluation Request form found on our

Website, at the Service Center on the Pendleton campus, or at any BMCC location. To evaluate credit transfers, the college requires official transcripts from other colleges.

Transferring Credits from BMCC

Up to 120 lower division transfer credit hours earned at a community college may transfer and be accepted toward graduation requirements by colleges and universities of the Oregon University System (OUS): University of Oregon, Oregon State University, Portland State University, Eastern Oregon University, Western Oregon University, Southern Oregon University, and Oregon Institute of Technology.

Discuss transferability of courses with both your academic advisor and the school to which you wish to transfer in order to facilitate a smooth transition from BMCC.

Appeal of Graduation Requirements

If you would like to request a course substitution to meet program requirements, you first must discuss this request with your advisor. If the advisor considers the request appropriate, he/she will complete the necessary paperwork, obtain the approval and signature of the instructor of the requested course, and then obtain the approval and signature of the vice president for instruction. The Registrar's Office will transcript the information, once approved, and it will become a part of your permanent record.

Graduation

You are responsible for fulfilling the requirements for graduation and should work with your advisor to ensure that you complete the degree and/or certificate requirements.

As a candidate for graduation, you are encouraged to complete an Application for Graduation form at least two terms before the term in which you expect to complete your program requirements (refer to the academic calendar in the catalog for specific deadline dates). This allows your academic advisor to assist you in selecting coursework necessary to meet your graduation requirements. Completed applications and payment may be submitted to any BMCC location.

Upon the college's receipt and processing of your completed graduation application form and applicable non-refundable fee, The Office of the Registrar will send you a graduation report (a list of courses still needed for graduation) and directions for viewing your completed degree audit. Your advisor will be notified by email that the degree audit has been completed. Should there be any discrepancy, you and your advisor will be asked to notify the Office of the Registrar. A graduation file will be established for you at that time. Your degree audit becomes your official degree check-off for graduation purposes.

Degrees and certificates become official when recorded on your transcript, and diplomas will be mailed to you within two months after final grades have been posted and reviewed. Diplomas will be mailed to the address listed on your application for graduation.

If you do not graduate in the term identified on your Application for Graduation, the Office of the Registrar will identify your final graduation requirements and communicate them to you and your advisor in writing. Your graduation file will be retained with the active files for a period of one (1) year from your intended date of graduation.

If you have not graduated after one year, your application will be returned to your student file and you will be required to reapply for graduation.

If you graduate with more than one degree, a separate Application for Graduation form must be filed for each degree. If you receive all degrees within one term, you will only be required to pay one fee.

Additional Guidelines:

BMCC reviews and updates degree requirements annually. Please note that some of the requirements for graduation may change if your studies are interrupted by two or more years or if a course of study extends beyond five years. Depending upon the college certificate or degree, you may be asked to complete updated requirements.

The following table outlines which catalog you may use in determining degree requirements for graduation.

Situation	Catalog of year started	Catalog of year re-started	Catalog of year Graduating
Attend concurrently for fewer than five years with no break in enrollment of more than two years	X		X
Re-attend with more than a two-year break in enrollment		X	X
Attend concurrently for longer than five years with no break in enrollment of more than two years			X
Attend for longer than five years with more than a two year break		X	X

Suspended Programs of Study

If BMCC suspends your program of study and if you are eligible for “teach-out” assistance as determined by the college, BMCC will work with you to help you complete the program within three years. Methods and types of assistance will vary by individual circumstance and will be available only to eligible students. Following the three-year period, if you have not satisfied your degree requirements for that certificate/degree but still wish to obtain a certificate/degree, you must either apply your earned credits to a different BMCC program or transfer them to another institution. Contact the Office of the Registrar to determine eligibility.

College Costs Tuition and Fees

Tuition and fees are subject to BMCC Board of Education policy and may be changed at any time.

Please refer to our Website, www.bluecc.edu, or call the college at 541-278-5759 to obtain current rates.

Students are considered to be full-time when they are enrolled for 12 credit hours or more.

In-State Residents: For tuition purposes, Oregon residents and residents of California, Idaho, Montana, Nevada, and Washington are charged at the in-state resident rate of \$66.00 for each credit hour, beginning with the fall term of the 2008-09 academic year.

Out-of-State Residents: The tuition rate for out-of-state students (other than the states listed above) is \$198.00 for each credit hour, beginning with the fall term of the 2008-09 academic year. If out-of-state students obtain Oregon residency, they may be eligible to receive a tuition credit during the first term in which they are an Oregon resident, not to exceed fifty percent of the tuition that they paid the previous term. For more information contact the cashier in the Office of Enrollment Management.

International Students: The tuition rate for international students is \$198.00 for each credit hour, beginning with the fall term of the 2008-09 academic year.

Senior Citizens: The tuition rate for a resident who is sixty-two years of age or older is fifty percent of the regular tuition rate for all credit classes. Course fees for non-credit classes will be at a flat rate of \$25. All other fees associated with the course will apply. Normal registration procedures are required.

In all above categories, certain courses may require an instructional course fee in addition to tuition. Fees are listed in the Schedule of Classes where applicable. In general, the fees applied are as follows:

- **Adult High School Diploma and Credit Recovery Fee:** \$30 for each half-credit each term plus a \$20 book fee.
- **Agriculture Course Fee:** \$30 each term if any agriculture class is taken; limit of one fee per student each term.
- **Art Class Fee:** certain courses are assigned a fee of up to \$30; fees are listed in the Schedule of Classes where applicable.
- **Audit Course Fee:** One-half of regular tuition and all associated fees.
- **Credit by Exam Fee:** One-half of regular tuition and all associated fees.
- **Deferred Payment Plan Fee:** \$20 (required minimum down payment of \$100)
- **Deferred Payment Plan Late Fee:** \$15
- **Dental Student Fee:** \$100 each term.
- **Distance Education Course Fee:** \$85 for each distance education course.
- **Dual Credit Fee:** \$10 for each credit transcribed.
- **EMT Fee—Basic A & B:** \$160 each term
- **EMT Fee—Intermediate-Part A & B:** \$130 each term
- **Graduation Fee:** \$30 (includes diploma)
- **ITV Course Fee:** \$25 per course for courses at the receiving locations
- **Late Add Fee:** \$100.00 for students adding a course after the add/drop date.

- **Late Payment Fee:** 3% of the unpaid balance with a minimum charge of \$10 and a maximum charge of \$75 per term. Fees assessed monthly until balance is paid in full.
- **Music Class Fee:** \$15 piano or voice.
- **Music Private Lesson Fee:** \$80.
- **Nursing Student Fee:** \$200 each term.
- **Official Transcript Fee:** \$5 for each transcript
- **Physical Education Fee:** \$10 for each course.
- **Prior Learning Credit:** One-half of regular tuition and all associated fees (up to 12 credits).
- **Replacement Diploma:** \$5
- **Replacement Diploma cover:** \$10
- **Replacement Diploma and diploma cover:** \$14
- **Returned Check Fee:** \$35 for each occurrence.
- **Science Laboratory Fee:** \$10 for each hour of laboratory per week.
- **Security Fee:** \$3 each term for students taking 1 or more credits.
- **Special Examination Fee:** varies (charges are based on the nature of the examination).
- **Special Program (ABE, GED, and/or ESL) Fee:** \$25 one time, each term.
- **Student Access Fee:** \$15 each term for students taking 1 or more credit hours.
- **Student Activity Fee:** \$1.50 for each credit hour.
- **Tech Fee:** \$1 for each credit for credit classes; \$1 per course for non-credit classes.
- **Welding Fee:** \$125 lab fee.

Payment of the stipulated fees by full-time and part-time students registered for academic credit entitles them to all services maintained by the college for the benefit of students. These services include use of the college student union, computer laboratories, library, laboratory and course equipment, materials in connection with courses for which the students are registered, and admission to some events sponsored by the college. By college policy, there is no reduction in fees for students who do not intend to avail themselves of these services.

Paying Tuition

Tuition and fees are payable in full by cash, check, or credit card (Visa or MasterCard) by the beginning of the sixth class day, or the equivalent percentage of days of terms or classes of varying length. Students may also use financial aid funds or third-party agency funds to pay their tuition and fees if they are eligible for these funds. Payments can be made at any location, by mail, or through the Student WolfWeb.

Tuition Installment Plan: BMCC's tuition installment payment plan is designed to assist students in paying their tuition and fees by setting a reasonable timetable and structure for payment. Students may sign up for this plan at any BMCC location, or through the BMCC Website. An agreement is not binding for the college until a representative of the business office has signed the completed form. Upon such signature, BMCC will return a copy of the signed document to the student. The plan will consist of a down payment of \$100 plus a \$20 processing fee. The balance of tuition and fees will be paid in two installments due at the fourth and eighth week of the term (or equivalent for terms of

varying length). Interest penalties of \$15 will be charged for each late payment.

Interest Penalties: Students who have not paid or made payment arrangements by the beginning of the sixth class day in fall, winter, and spring terms, or the equivalent day of terms or classes of varying length will be assessed late fees. The fee is 3% of the balance due assessed monthly until the balance is paid. The minimum charge is \$10, and the maximum charge is \$75 per term.

Stop-Payment Fees For Financial Aid Refund Checks:

If you are eligible for a financial aid refund check and it does not arrive at the address indicated on your student account after ten days from the date of issuance by the college, BMCC will re-issue the check without charge to you. If you wish the college to re-issue the check before the 10-day period is over, BMCC will charge you a \$35 stop-payment fee.

Tuition Refund Policy

Students who withdraw from courses and who have complied with regulations governing withdrawals are entitled to certain tuition refunds depending on the time of withdrawal. Tuition refunds are calculated as follows:

- First five class days or the equivalent day of terms for classes of varying length: 100 percent.
- After the first five class days or the equivalent day of terms for classes of varying length: 0 percent.

Financial Assistance

Federal School Code: 003186

Federal and State Aid

Blue Mountain Community College's Student Financial Assistance Office is located in Morrow Hall on the Pendleton campus and can be accessed through the Service Center. Please check the BMCC Website for hours of operation. You may contact the Student Financial Assistance Office by phone at 541-278-5759 or by email at finaid@bluecc.edu. The financial assistance staff is available to students to help in applying for and receiving the following sources of financial aid:

- Federal and state aid
- Certification of a veteran's education benefits
- Student employment
- BMCC tuition scholarships (athletic, music, drama, and skills challenge)
- Miscellaneous outside scholarships
- Emergency loans (available on a very limited basis and as funding allows)

BMCC participates in the following types of federal and state aid:

- Federal Pell Grant
- Federal Supplemental Educational Opportunity Grant (FSEOG)
- Academic Competitiveness Grant (ACG)
- Federal Work Study
- Federal Family Education Loan (FFEL, Federal Stafford-Subsidized and Unsubsidized)
- Federal PLUS (Parent Loans for Undergraduate Students)
- Oregon Opportunity Grant

Applying for Federal and State Aid: Students must file a FAFSA (Free Application for Federal Student Aid) form annually in order to receive federal and state aid. You may apply online at www.fafsa.ed.gov or may complete and submit a paper application. Be sure to include BMCC's Federal School Code (003186) so that BMCC receives the FAFSA information. Applying online can reduce the amount of time for processing financial aid by approximately three weeks. Note: January 1 is the first day of the financial aid application period for the next academic year.

Disbursement of Aid: If students have a credit balance on their student account after all charges have been covered, they will receive a check for the balance of their financial assistance funds. Checks are available on the second Wednesday of each term. For actual disbursement dates, please check the Office of Financial Assistance 'Dates and Deadlines' page on our Website.

Aid-Ineligible Courses: Students need to be aware that, depending upon which degree they are seeking, there may be courses that are deemed aid-ineligible. For a current list of aid-ineligible courses by degree or certificate, refer to the Office of Student Financial Assistance 'Policies' page on our Website, www.bluecc.edu.

Mid-Year Transfer Students: If you transfer to BMCC during the academic year and received financial aid at the previous college, you should contact the BMCC financial assistance office as soon as possible to determine your actual award amount. For most mid-year transfer students, the federal or state aid award at BMCC will be reduced by the amount of aid received at the previous college.

Taking Courses at BMCC AND Another Institution (Co-enrolled): If you are planning to take courses from BMCC and another college during the same term, you must complete a consortium agreement form and a transfer-course evaluation form. Once processed, the consortium agreement is valid for one academic year; however, you must complete the transfer-course evaluation form for each term and for each college from which you plan to take courses. To obtain forms and additional information regarding co-enrollment, contact the Office of Student Financial Assistance Office at 541-278-5790 or by e-mail finaid@bluecc.edu.

Second Degree: If you have received an associate's, bachelor's, or master's degree and wish to receive financial aid from BMCC, you must complete a length of time (LOT) appeal and submit it, along with appropriate documentation, to the Student Financial Assistance Office. You will be notified in writing of the decision made within two weeks. This process does not guarantee an award.

Total Withdrawal and Return of Federal Aid: If you withdraw from or quit attending all classes before completing more than 60.01 percent of the term for which you are eligible, BMCC will recalculate your aid award based upon the percentage of the term completed. For example, if you withdraw after completing only 30 percent of the term, you will have earned only 30 percent of your federal aid received (other than Federal Work Study). You and/or BMCC, as

determined by college and federal rules, must return (repay) to the federal government the remaining 70 percent of the federal funds received. This policy applies to all students receiving federal Title IV aid who withdraw, drop out, or are suspended from BMCC. Types of federal Title IV funds that students can receive while attending BMCC included in this policy are: Federal Pell Grant, FSEOG, ACG, and FFEL (Federal Stafford Loans).

For additional information regarding this policy and for more detailed information about financial aid, please visit BMCC's Website or contact the Office of Student Financial Assistance.

Other Financial Assistance

Foundation Scholarships

The Blue Mountain Community College Foundation offers scholarships to both full- and part-time students. Scholarship information and scholarship applications are posted on the college Website. Most full-time scholarships are awarded during spring term for the next academic year. Scholarships for part-time students may be available each term. An applicant must be enrolled before a scholarship can be awarded. Stipulations concerning financial need, credit hours, grade point average, and area of study may apply. The BMCC Foundation posts information on its scholarships as well as information that it receives from local civic groups; fraternal organizations; and state, regional and national agencies. For further information, contact 541-278-5775.

High School Student Tuition Scholarship

BMCC has scholarships available to students graduating from each of the high schools located in our tri-county area. Applications are available in February at each of the area high schools and have a March deadline. Students should contact their high school counselors for further information.

Emergency Loans

BMCC's emergency loan procedure is designed to assist students with direct educationally related costs (books and supplies) in the period between the start of classes and financial aid disbursement. A student may, in very rare instances, receive an emergency loan without the benefit of forthcoming financial aid. Applicants must demonstrate a need that is unanticipated in nature or is the result of an unanticipated expense. If a student is receiving financial aid, he or she must demonstrate a need that cannot be deferred until the day of financial aid disbursement. For assistance with this process, please contact a staff member at any BMCC location or by email finaid@bluecc.edu.

Book Vouchers

The book voucher program helps students whose financial aid award exceeds their tuition and fees to purchase texts and materials for classes during the period between the start of classes and the disbursement of financial aid. If you qualify, you may obtain book vouchers at the BMCC Service Center on the Pendleton campus, or you may work with the staff at the BMCC location where you are attending classes. The college will apply bookstore charges to your student account and will deduct the amount from your available financial aid. In no case may you incur charges beyond the amount in your account.

Student Employment

BMCC has a variety of positions open to students throughout the year. Please contact the Office of Student Financial Assistance Office, at 541-278-5790 or finaid@bluecc.edu, for additional information, to view open positions, and apply for jobs. If you are hired as a student worker, you must attend a new student employee orientation session and complete all required paperwork before employment can begin. For information including the Student Employment Handbook, and a list of available positions, go to www.bluecc.edu.

Veterans' Educational Benefits

BMCC's certifying official for veterans' affairs is located in the Office of Student Financial Assistance Office in Morrow Hall on the Pendleton campus.

General Information about Applying: In order to receive Veterans Administration (VA) educational benefits veterans must:

- ✓ Take the BMCC placement test to determine proper course placement before enrollment
- ✓ Be assigned an academic advisor
- ✓ Be pursuing a BMCC degree or certificate

If you qualify as a veteran or as a survivor or dependent of a veteran, you must follow the appropriate procedure outlined below in order to begin receiving educational benefits.

(Chapter 30)—Discharged from Active Duty

Apply for education benefits (Form 1990) online at <http://vabenefits.vba.va.gov/vonapp/main.asp>

Once you have completed the online application, you must provide the office with all of the following completed documents:

- ✓ Copy of your DD-214
- ✓ BMCC enrollment certification information form
- ✓ BMCC veteran's student rights and responsibilities form

(Chapter 1606)—Reserves

Apply for education benefits (Form 1990) online at <http://vabenefits.vba.va.gov/vonapp/main.asp>

Once you have completed the online application, you must provide the office with all of the following completed documents:

- ✓ Copy of the Veteran's Notice of Basic Eligibility (NOBE)
- ✓ BMCC enrollment certification information form
- ✓ BMCC veteran's student rights and responsibilities form

(Chapter 35)—Dependents' Education Assistance

Survivors and dependents education benefits (Form 5490) online at <http://vabenefits.vba.va.gov/vonapp/main.asp>

Once you have completed the online application, you must provide the office with all of the following completed documents:

- ✓ BMCC enrollment certification information form (to include the VA file number of the veteran)
- ✓ BMCC veteran's student rights and responsibilities form

The BMCC enrollment certification information and BMCC veteran's student rights and responsibilities forms can be found on the Financial Assistance page of BMCC's Website.

Note: other documentation may be required depending on the VA chapter. The veterans' clerk may certify a veteran's enrollment for up to one academic year. A new enrollment certification form must be completed each year. Contact the veterans' clerk at 541-278-5790 or email finaid@bluecc.edu for more information.

Send completed information to the veterans' clerk at BMCC, P.O. Box 100, 2411 NW Carden, Pendleton, OR 97801. Please allow two to three weeks for processing and certification of your enrollment to the VA. Upon receipt of the certification, the VA may take additional time to process your payments. Typically, students are paid monthly for the prior month's enrollment. For example, you will receive payment in the month of October for September class days, and in November you will receive payment for October. Tuition will be due before you receive your first VA payment. If you are unable to pay your tuition in full by the due date, you may set up a tuition installment plan with the BMCC Business Office on or before the due date. If you cannot make any payments, late fees will be added to the cost of your tuition if you do not drop the courses by the specified date. Tuition due dates are posted on our Website, in the student handbook, and at various locations at the Pendleton campus and the college locations.

Additional Information About Veterans' Benefits:

The following rules apply to non-punitive grades. Benefits will not be paid for a grade of audit (AU). If a grade of incomplete (INC) is given, the veteran has one year from that date to complete the class and receive a letter grade.

Program Changes: If you will be changing your degree program you must contact the veterans' clerk immediately and complete a Change of Program form. The veteran's clerk will submit the change to the VA.

Transfer Students: Students must provide official grade transcripts from all colleges or postsecondary schools previously attended. Transcripts should be sent to: Blue Mountain Community College, Office of Enrollment Management, P.O. Box 100, 2411 NW Carden, Pendleton, OR 97801.

It is the responsibility of the veteran to request a transcript evaluation from the Office of the Registrar at the Pendleton campus. In addition, a Change of Program form must be completed and returned to the veterans' clerk. The veterans' clerk will forward all changes to the VA. The veterans' clerk may certify up to one term in a pending status while awaiting completion of the transcript evaluation. If the evaluation has not been completed by the end of that term, the veterans' clerk will make no further certification until he/she has received the completed evaluation.

Advance Pay Request: Veterans who need financial aid to begin classes may request advance pay for the first term. Requests must be made four to six weeks before the beginning of the term. With advance pay, veterans are paid

for the first two months of the term; however, the VA pays based on the number of days that the veteran was enrolled for a given month. For example, if fall term begins the last week of September, the advance paycheck would be for part of September and all of October. The advance check is sent directly to the BMCC Business Office.

Certification Periods: The VA clerk will certify enrollment based on BMCC's official academic calendar. Some courses vary in length. The VA clerk will certify enrollment according to each course's beginning and ending dates, which may affect the rate of pay. If you have questions, please contact the VA clerk.

Pay Table: Rates of pay depend on the veteran's chapter and his or her enrollment level. BMCC will inform the VA of any changes during the term, which may result in adjustments to the monthly allowance. It is the veteran's responsibility to report any changes to the veterans' clerk. Pay rates are updated each year, usually in October. Veterans may be eligible for additional tuition assistance, or "kickers." The VA can provide information regarding eligibility. Additional information and the current pay table are available at www.gibill.va.gov or at the Veterans Administration by calling 1-888-442-4551.

Other Assistance to Veterans

In addition to certifying standard veterans' benefits, BMCC offers the following benefits to veterans and their spouses:

Returning Veterans Enrollment Incentive: This benefit is available to any member of the armed services currently on active duty or honorably discharged within the last eighteen months. Veterans who qualify will have the first year of tuition for credited classes discounted by fifty percent. This benefit does not cover books, supplies, and fees, unless they are funded by the Montgomery GI Bill or tuition assistance.

Tuition Waiver for Spouses of Deployed Military Personnel:

This benefit pertains to military spouses and dependents of military personnel deployed with units of Army/Air National Guard and other military services. Applicants need to provide orders or other verification from the branch of service of eligibility to BMCC's veterans' clerk. The Oregon State Military Education Department can assist in the process of verifying deployment orders and dependency issues. Qualifying students are charged tuition of 50% for each credit up to 12 credits, with a minimum class load of 6 credits. For any credits taken above 12, the student pays full tuition. Credit will not apply to non-credit classes.

For additional information, please contact the Office of Student Financial Assistance at 541-278-5790 or by email at finaid@bluecc.edu.



Services and Programs for Students

Academic Services

Testing Services

Testing services are available at all BMCC locations. Services will vary by site. Contact the BMCC center nearest you for schedules, appointments, and details.

The testing centers provide placement testing services to help a diverse student population successfully achieve a variety of educational goals. The testing centers also provide test proctoring services for distance education students, special accommodations testing, and GED testing. In addition, the Testing Center on the Pendleton campus provides testing services for a variety of tests for professional licenses and certifications. Information on other testing services is available upon request.

Academic Advising

The Academic Advising Philosophy at Blue Mountain Community College states, “Academic advising is a collaborative process through which advisors assist students with timely, meaningful educational planning that is compatible with the students’ life goals. The advisor serves as an advocate and resource in an interactive partnership with the student. Advising encourages students to think critically, seek out resources, and develop action plans.”

To help ensure student success, BMCC requires all degree-seeking students, whether full- or part-time, to work with an advisor to plan and develop his or her academic career path. Advisors work with students to help ensure they are taking classes that apply to their chosen degree plan and that are appropriate for the students’ level of readiness and preparedness for a variety of courses. Advisors also help students navigate the complex world of degree audits, graduation, academic support systems, and transfer information.

An advisor will be assigned to students seeking a degree, however, academic advising is available for every student at BMCC, whether degree-seeking or not, to help them effectively plan to meet their educational goals. There is an advisor for every academic program at BMCC. Students planning to transfer to a four-year college or university can find catalogs, applications, scholarship information, and other helpful information from all Oregon University Systems schools and other colleges in the Pacific Northwest by contacting the advising department at the Pendleton campus or by visiting the Library.

To see an advisor, you can call or stop by the advising center in Pendleton (Morrow Hall, room 118), call 541-278-5931 in Pendleton, or contact the center nearest you to have

an advisor assigned. You can set up appointments directly through your assigned advisor, or the centers can set them up for you.

Timberwolves Introduction

Timberwolves Introduction (Twi) is a mandatory six-hour workshop for all new and transfer students. Twi introduces students to academic culture, purpose, expectations, resources, procedures, and policies. Advising, registration, student activities, success strategies, and career information are also covered during Twi. Degree-seeking students entering BMCC for the first time—including transfer students—will be assigned or asked to choose a Twi session that meets their schedule. Twi is open to all students, whether degree-seeking or not. Spouses, parents and significant others are also invited to attend so they can explore ways to support and encourage their BMCC student. Students must register for Twi sessions prior to or during their first term of attendance..

Bookstore

The BMCC Bookstore is located adjacent to the library in Pioneer Hall at the BMCC campus in Pendleton and provides services to all students at all BMCC locations. Bookstore products and services include new and used textbooks, study aides, calculators, school and art supplies, sundries, and stamps. The Bookstore also offers a wide selection of clothing, gifts, snacks, and beverages. Academic pricing on computer software is also available to those who qualify.

Textbooks are also made available at the centers in Baker City, Milton-Freewater, and Hermiston for classes held at those campuses. If you are taking classes at any of these locations and have questions about textbook purchases, please contact the local center directly. Please contact the Bookstore for our book refund and buy-back policy.

For your convenience, the Bookstore provides a Website for ordering textbooks online, www.bookstore.bluecc.edu. For more information or questions regarding the site, please contact the Bookstore at 541-278-5733.

Copy Center

The BMCC Copy Center is located in the Bookstore in Pioneer Hall on the Pendleton campus and is open to the public. The Copy Center offers a variety of services including black and white or color copies, term paper covers, resume printing, laminating, and various types of binding, among others. It is available for drop-off service. Please stop in and speak with a member of the Copy Center staff for more information, or call 541-278-5966.

Student Union Cafeteria

The Pendleton campus houses the BMCC Student Union and Cafeteria, located in Pioneer Hall. The cafeteria is operated by a local and privately run business.

In Fall 2008, Simply Catering will be offering a revised and updated menu. Simply Catering strives to provide breakfast, lunch, and refreshments. Simply Catering supports the college faculty, staff and students by assisting with special events and college catering. If you need any of these services, please call 541-278-5946.

The hours of operation are Monday through Thursday, 10:00 a.m. to 1:30 p.m. Payment methods include cash, check, or debit card. The cafeteria is closed on Fridays, Finals Week, holidays, Christmas and Spring Breaks, and summers. On Fridays, student clubs may sponsor special lunch events.

Library

The BMCC Library plays a vital role in the teaching and learning process. Through its various services, the library connects people, technology, and resource collections for student success in academics and in the pursuit of lifelong learning goals.

Located in Pioneer Hall on the Pendleton campus, the library provides a physical space for BMCC students, staff, and faculty and the general public to use a carefully selected collection of books, audio and video tapes, DVDs, periodicals, and newspaper subscriptions. Individual carrels accommodate quiet study while mezzanine rooms provide for small group work and media listening/viewing sessions. Computer workstations and networked study carrels for laptops are available along with a copier, scanner, and laser printer.

The library's Web-based homepage, www.bluecc.edu/library, expands its collection and the availability of academic products and library services to students. Here, research is guided by links to subscription-based indexes and full-text databases, recommended Websites, request forms, study aids, and tutorials. The online public catalog provides rapid identification of media and print holdings at BMCC, other schools, and public and academic libraries in eastern Oregon. BMCC library cards, available to all students, allow access to additional services, including remote access to web-based journal and newspaper databases, electronic reserves, and direct online requests for materials not in the BMCC library. Librarians and staff are available for reference assistance and course-related research instruction either in person or through "Ask a Librarian" feature on the Website.

Regardless of when and where you participate in courses, the library is available to teach you to retrieve and evaluate information in a society that places increasing importance upon these skills. For more information, call 541-278-5915.

Services for Students with Disabilities

Disability Services is committed to providing equal access to all qualified students with disabilities. Providing academic adjustments and auxiliary aides and services to students with disabilities to remove barriers to physical spaces and

program access is an important goal at BMCC. Faculty and staff members are informed, understanding, and supportive.

Students may request services any time and must qualify for services by providing appropriate documentation of their disability(-ies) at the time of the initial request. Those requiring assistance with any step of the process for services for disabilities or with any process on campus (such as admissions and financial aid) may work with the student success advisor (SSA), located at the Pendleton campus but available to all students at any BMCC location, to make the process smoother. Once the student has been qualified for services, the SSA and the student will work together to determine which services will most benefit the student in a particular situation. All accommodations are arranged on an individual basis.

Each campus is equipped with a computer featuring some of the most popular assistive technology available.

Other available support services include, regular campus visits by agencies, academic and career advising, special parking, and resource and referral information. Some accommodations take time to prepare and require advanced notice. For further information, contact Disability Services at 541-278-5931.

Tutoring Program

Housed in the new Student Learning Center in Morrow Hall, the tutoring program offers drop-in tutoring and peer-tutoring to students who would like assistance with their classes. The tutoring program is provided at no cost to all BMCC students. If you want tutoring, drop by the information desk in the Student Learning Center or complete an online tutor request form at www.bluecc.edu. Instructors may also refer students who need tutoring to the Student Learning Center. If you want to be a peer tutor you must apply to the Department of College Preparatory Programs and then be approved by the instructor. The number of peer tutoring positions is dependent upon instructor approval and available funding.

TRiO Student Support Services

TRiO/Student Support Services works with students to provide comprehensive academic support. Nationwide, students who are part of a TRiO program tend to have higher GPAs and earn more credits than those who are not involved with TRiO. The TRiO program at BMCC offers a student computer lab, professional and peer tutoring, advising and four-year transfer assistance, workshops on study strategies and time management, book and calculator loans, snacks, and a place to meet other BMCC students.

To qualify, you must be a U.S. citizen, be seeking a degree, and meet at least one of the following criteria: be a first-generation student (neither parent graduated with a bachelor's degree), have low income, or have a documented disability.

For more information or to learn if you qualify, drop by the TRiO offices on the Pendleton campus in Morrow Hall, Room M141, or call 278-5853. The application is also available online at www.bluecc.edu.

Co-Curricular Activities

Athletics

BMCC participates in both the Northwest Athletic Association of Community Colleges (NWAACC) and the National Intercollegiate Rodeo Association (NIRA). The NWAACC is the parent organization for thirty-six community colleges in Oregon and Washington. BMCC sponsors athletic teams under the NWAACC, including women's volleyball, men's and women's basketball, women's softball and men's baseball. The BMCC rodeo team competes in the NIRA Northwest Region with universities and colleges from Oregon, Washington, and Idaho. NWAACC and NIRA colleges provide a variety of academic and vocational offerings as well as many enrichment activities for their students.

Under the guidance of BMCC's coaches and athletics director, student athletes are part of an athletic program that:

- Stresses academic, personal and athletic excellence
- Strengthens success-producing traits such as dedication, discipline, focus, integrity, communication, organization and leadership
- Emphasizes the value of teamwork
- Creates a positive, lasting memory of BMCC for each athlete

BMCC has been active in the rodeo world almost since the college was founded. Our men's and women's rodeo teams compete in intercollegiate rodeos throughout the Northwest and nationally. The team has enjoyed great success over the years by winning numerous regional championships and by winning the national championship in 1987 and the national reserve championship in 1999. The BMCC rodeo team has produced many regional and national champions who have gone on to participate in the Professional Rodeo Cowboys Association (PRCA) and become world and national PRCA champions.

If you are interested in becoming part of the Timberwolves' pride and spirit, please contact the BMCC Athletics Department or team coach.

BMCC Athletics Department	541-278-5900
Baseball	541-278-5900
Women's Softball	541-278-5895
Men's Basketball	541-278-5893
Women's Basketball	541-278-5894
Women's Volleyball	541-278-5910
Men's and Women's Rodeo	541-278-5930

Clubs

BMCC offers a variety of student activities that enhance the cultural atmosphere of the Pendleton campus and provide educational, recreational, social, and leadership opportunities for interested students. For more information contact the Associated Student Government (ASG) club coordinator in the ASG Office in Pioneer Hall on the Pendleton campus.

Housing

BMCC does not provide on-campus housing nor do we recommend, endorse, or make claims of any type concerning private housing available in our district. We do, however,

provide a listing on our Web site of property management companies that have rentals available to students. In addition, local newspapers in the region list available housing.

Music

The Department of Music offers opportunities for students to participate in a variety of performing groups such as choir, vocal jazz ensemble, jazz band, and two local symphonies. Students may take guitar, piano, and voice lessons to develop musicianship and songwriting skills. For more information about this program, please call the music department at 541-278-5174.

Publications

Wolf Echos is the campus newsletter written, edited, and managed by the Associated Student Government. If you are interested in contributing information or articles may contact the ASG publicity officer at 541-278-5948 or by email at: asgbmcc@bluecc.edu

Student Ambassadors

BMCC student ambassadors represent various regions, programs, issues, and interests of the student body. They participate in recruitment events and college fairs, visit high schools, give campus tours, contact potential students, and represent BMCC to the community.

The student ambassadors' primary function is to provide leadership, assistance, and information to prospective BMCC students. The program is an exciting opportunity that helps students develop their leadership skills, while making lifelong friends. By becoming an ambassador, you can make a difference in a prospective student's outlook by giving him/her information about the transition into college life and how to make the most out of the college experience.

In exchange for weekly service, student ambassadors receive tuition waivers and leadership training. Each spring, the college selects ambassadors for the following academic year. For more information contact the Outreach Office 541-278-5936.

Student Government

Blue Mountain Community College has an active student government that is supported through the Office of Enrollment Management. The Associated Student Government (ASG) is responsible for planning various cultural, governmental, and entertainment events as well as contributing to college governance committees. The executive committee of the ASG consists of the president, vice president, secretary, treasurer, club coordinator, publicity director, and outreach liaison officer. The remaining members of the ASG are student senators. If you are interested in becoming an active member of ASG, please contact an executive committee member at 541-278-5948 or by email at asgbmcc@bluecc.edu. All BMCC students are encouraged to become involved.

Theater Arts

The BMCC Theater Arts Program has a forty-year history of collaborating with the local College Community Theatre organization and with the Music Department in producing

three main-stage productions each academic year in the 280-seat Pioneer Theater on the Pendleton campus. These productions offer our students and the general public excellent creative opportunities and essential training for performance-based careers. In the spirit of community-driven theater, students are given direct experience within all areas of theatrical production, including acting, scenic, lighting, costume design and building, stage management, and assistant directing. For more information contact the Fine Arts Department at 541-278-5944.

College Preparatory (CP) Programs

The College Preparatory Programs department is located in Morrow Hall Room 135 on the Pendleton campus. The hours of operation are Monday through Friday 8 a.m. to 5 p.m.

The College Preparatory department includes the following program areas: adult basic education (ABE), general educational development (GED) preparation, adult high school diploma (AHSD), English as a second language (ESL), the JOBS program, college preparation courses, and the tutoring program. The department also offers the following transfer courses: HD100 College Survival and Success, HD110 Career Planning, and HD109 Academic Planning. For more information about any of these programs, call 541-278-5803 or visit us on the Web at www.bluecc.edu.

Adult Basic Education (ABE)

The ABE program serves students who are at least sixteen years of age and not enrolled in school. Students who are sixteen and seventeen must have a release from the high school district in which they reside. Students in the ABE program must take CASAS tests as part of the entry requirements and demonstrate functioning skills below the post-secondary level.

ABE instruction is available for students interested in improving basic skills in reading, writing, and/or math. ABE programs operate at the following BMCC locations: Pendleton, Hermiston, Baker City, Milton-Freewater, Boardman, Enterprise, Wallowa, and John Day.

Adult High School Diploma (AHSD)

The AHSD is designed for students who choose to fulfill competency requirements deemed necessary for a high school diploma in Oregon. Students can earn credits by attending approved college courses. As a general rule, this program serves those who need three credits or fewer to complete high school requirements. Students earning an AHSD through BMCC may participate in the BMCC commencement exercises held in June. Students must submit high school transcripts to be evaluated by the college before beginning the program. Students must work closely with the high school that will be transcribing courses for high school credit and issuing the diploma, their BMCC advisor, and the CP department to ensure that college credits will count toward the AHSD.

English as a Second Language (ESL)

ESL instruction is offered for people for whom English is not their primary language. They can receive instruction in oral communication, adult survival skills, and English reading and writing skills. ESL courses are available at the following BMCC locations: Pendleton, Hermiston, Milton-Freewater, Boardman, and Baker City.

General Educational Development (GED)

GED preparation is available for students who are studying to pass the battery of GED tests. Instruction in reading, writing, and math is available in the classroom or by distance education. GED preparation courses are available at the following BMCC locations: Pendleton, Hermiston, Milton-Freewater, Boardman, Enterprise, Wallowa, and John Day.

Students earn the GED certificate when they receive passing scores on the five parts of this standardized exam. A school release is required before an individual under eighteen years of age may attempt the test. Information on testing and school release may be obtained from the BMCC testing center in Pendleton at 541.278.5931. Students earning a GED may participate in the BMCC commencement exercises held in June.

JOBS Program

JOBS for Oregon's Future (JOBS: Job Opportunities and Basic Skills) is the state's employment and training program for people on public assistance. In addition, JOBS can help low-income families avoid the need for welfare.

Through contract with the Oregon Department of Human Services, BMCC provides JOBS Program services in Umatilla County, including employment assessment, work-search assistance, and training in workplace basics and life skills. Clients receiving help through the Temporary Assistance for Needy Families Program may be eligible for JOBS Plus services, which places persons in limited-duration training positions with private employers. As part of BMCC's Department of College Preparatory Programs, the JOBS Program works closely with basic skills offerings as well as with other BMCC educational services in order to help JOBS students meet their goals.

The JOBS Program is located at BMCC Hermiston, BMCC Milton-Freewater, and the Oregon Employment Department in Pendleton. For more information, please call the JOBS Program manager at (541) 938-4082 x3172.

College Preparation Courses

College preparation courses include language arts, math, and writing. A student's COMPASS placement score determines whether and at which level the student should be placed into a college preparation course. Students can also decide independently to take college preparation courses to improve their basic skills knowledge. Instructors also may refer students whose academic performance indicates they would benefit from additional college preparation. In addition, students can be referred by their instructors based upon the student's performance in class. College preparation courses are offered at the following BMCC locations: Pendleton, Hermiston, Milton-Freewater, and Baker City.

Other Programs

Continuing Education

BMCC is committed to lifelong learning and serves the needs of adult learners by providing a wide variety of innovative, high quality, community-driven, and affordable courses through our community education program. These courses include a variety of non-credit, short-term courses, workshops, lectures, and personal interest/hobby courses. For more information on what is being offered or to request a specific course, contact your local BMCC location or call 541-278-5786 in Pendleton.

Community Education

The community education program is part of the college's commitment to make educational services available throughout the college district by offering educational programs and opportunities designed to help adults of all ages reach their vocational objectives and realize their personal potential. A primary emphasis for the college is working with business and industries to provide a variety of training programs that can be delivered on-site or at one of the college's facilities. These programs can be tailored to meet the specific needs of business or industry clients, providing a timely, relatively inexpensive solution to their training needs. For more information on courses customized to your business or to schedule a special training, call your local BMCC center or 541-278-5786 in Pendleton.

Academic Partnerships

Business Partnerships

Apprenticeship

Apprenticeship training as a method of vocational education is recognized by the Apprenticeship and Training Division of the Oregon Bureau of Labor and Industries (BOLI). It combines full-time, on-the-job training with committee approved contractors and trade related instruction taken in conjunction with each other. Apprenticeship courses are approved for BOLI-registered apprentices or journey-level men and women and are not available to the general public.

BMCC's apprenticeship program offers associate of applied science degrees and certificates of completion for professionals in the areas of inside electrician; manufacture plant electrical; limited maintenance electrical; plumbing; and programmable logic controller technician as part of Oregon's community college general apprenticeship pathway. The program provides statewide transfer opportunities, certificates of completion, and an optional transfer path into a bachelor of science degree in operations management at the Oregon Institute of Technology. Electricians and plumbers require state licensure. Related training courses meet industry standards and are offered through a partnership between the Oregon State Apprenticeship Training Council and the local Joint Apprenticeship Training Committee.

If you are interested in becoming registered in an Oregon State Apprenticeship program, please contact the Oregon State Bureau of Labor and Industries Apprenticeship Training Division at 971-673-0761 or www.boli.state.or.us for program and entrance requirements. For more information on

BMCC's apprenticeship certificates and degrees, see page 51 and 59 of this catalog, or contact 541-278-5854.

Cooperative Work Experience (CWE)

Students may earn college credit for cooperative work experience (CWE) related to their occupational goal. Such work experience must take place at work sites approved by the college and be monitored by the course instructor. The experience may be in business, industry, agriculture, or education, or with public service agencies that are willing to enter into work experience agreements with the college.

To find out more about the CWE program, check with the course instructor, your advisor, or contact the Office of Instruction.

Small Business Development Center/Small Business and Farm Management Programs

BMCC opened its **Small Business Development Center** (SBDC) in 1984 under a federal partnership with community colleges and universities throughout the United States to help start-up and established businesses. There are now more than twenty SBDCs in Oregon and more than 1,000 in the nation.

Whether you are starting a new business or growing an existing one, make the SBDC your first stop. Located at our Pendleton and Hermiston offices, our SBDC staff offers free, confidential counseling by experienced business professionals; learning and reference materials; workshops and courses; and free high-speed Internet access and videoconferencing.

Small business owners and managers must compete and succeed in a rapidly changing business environment. BMCC's **small business management (SBM) program** assists small businesses with management practices that ultimately increase productivity, profitability, and that help to develop the owner and/or manager's ability to organize resources that maximize the potential for meeting business and personal goals. The Small Business Management Program focuses on areas such as: **planning; record-keeping, marketing, finance, human resources, computer applications and much more.**

Students in the SBM program must be actively engaged in the ownership, management, or operation of a small business. To be successful, participants must be willing to attend class once a month with other non-competing small business owners/managers and to participate in monthly on-site visits by the instructor.

The Small Business Management Program is a unique multi-dimensional learning experience that is convenient (a portion of the class sessions are on line) and very affordable. A wide variety of businesses have participated during the program's twenty years of operation.

BMCC's **Farm Business Management (FBM) Program** provides education to farm owners and operators. Formerly under the umbrella of BMCC's agriculture department, the FBM program has a new home, but the purpose of the program remains the same: to assist students in meeting their

business and personal goals through accurate record-keeping and sound business decisions. Effective financial management in the business is the best way for the business to maintain that competitive edge.

The FBM program provides instruction in accurate record keeping and accounting, information-based decision making, and projecting and analyzing costs of production. The program introduces user-friendly business tools and provides support for implementing management plans and strategies. The primary delivery method is through individualized instruction at the student's place of business.

Contact us today toll-free at 888-441-7232; in Pendleton at 276-6233; or in Hermiston at 564-0921, extension 3341. You also can email sbdc@bluecc.edu or check www.bluecc.edu.

High School Partnerships

Dual Credit Program

In cooperation with many high schools and the local education service district (ESD), BMCC offers a state-approved dual-credit program. Students at a public high school that has an articulation agreement with BMCC may meet the educational requirements of both the high school and a college-level BMCC course if they are enrolled for dual credit in a class taught at the high school. This challenging course work offers students the opportunity to begin building a college transcript while still enrolled in high school. Dual-credit courses and credits appear on a BMCC transcript as though they were taken at BMCC. Dual-credit courses normally transfer to four-year institutions in the same way as any other BMCC course work. Not all courses are available at every high school. High school students may check with their high school counselors and teachers for course availability, costs, and other requirements, or they may check with the ESD for further information. Students should also check with the college to which they wish to transfer, if they want to ensure that dual-credit course work will transfer.

Expanded Options

BMCC offers a dual-enrollment program that conforms with the Oregon Expanded Options legislation (also known as SB300 and SB23). This program offers high school students the ability to take BMCC classes to earn college credit and earn credit toward high school graduation at the same time. Depending on each high school's policy, a high school may pay all or part of the cost of the college classes. Each high school sets its own criteria for entry into the program and monitors student progress. College-level credits earned are transcribed through BMCC and are transferable to other colleges.

Though similar, the dual-credit and expanded options programs have distinct differences:

- Students participating in the dual-credit program take classes at their high school from high school instructors and earn college credit at the same time
- Students participating in the expanded options program take a college course from college instructors with other college students and earn high school credit at the same time; the high school pays all or part of the cost of the college course

If you are interested in one or both of these opportunities, contact your high school or ESD or contact the Office of Enrollment Management at BMCC.

Inter-College Partnerships

Eastern Oregon Collaborative Colleges Council (EOCCC) BMCC, Treasure Valley Community College (TVCC), and Eastern Oregon University (EOU) have worked together in several academic disciplines to improve articulation opportunities for students, allowing them to share lower division course work among BMCC, TVCC, and EOU; to transfer those credits to EOU; and to complete upper division courses at EOU culminating in a four-year degree.

For more information on the co-enrollment process, please go to the Service Center or call 541-278-5759.

Oregon State University Dual Admission

Through an agreement with Oregon State University (OSU), BMCC students may be jointly admitted to BMCC and OSU and be eligible to enroll concurrently at both institutions. There is a joint application process for eligible students; the admission deadline is one week before the start of classes of each term based on OSU's academic calendar. Students enrolled in the program are required, as a condition of admission, to agree that their student records will be shared between and available to each institution. For more information on this program, contact BMCC's Office of Admissions and Records.

Articulated Degree Programs

BMCC enjoys articulation agreements with a variety of institutions. The following agreements allow you to attain your degree while staying in your local area.

CUESTE: Teacher Education Program

CUESTE (pronounced quest) stands for Curriculum of Undergraduate Elementary School Teacher Education and is a collaborative program between BMCC and Eastern Oregon University (EOU).

Students seeking elementary teacher licensure need to complete a major in multidisciplinary studies; a minor in an academic area, endorsement area, or course of study; and a minor in elementary education. When students are within 100 credit hours of finishing the CUESTE program requirements, they may apply to EOU's CUESTE program. The completion of CUESTE program requirements leads to a bachelor's degree (science or art) in multidisciplinary studies, a minor in elementary education, and certification in primary (age 4 through grade 4) and elementary (3-8) grades. Through the CUESTE program, BMCC offers the first two years of the associate of arts transfer (A.A.O.T.) degree, and EOU provides the last two years of the elementary education degree at BMCC's Pendleton campus.

Two full-time EOU education professors are in residence at BMCC's Pendleton campus to advise students, teach classes, and coordinate EOU and BMCC processes. (Please note: Much of the major course work for secondary teaching certification may be acquired through distance education courses available from EOU and BMCC. However, the

secondary education component needs to be completed on EOU's campus in LaGrande.)

CUESTE is a highly prescriptive program that entails several key elements:

Multidisciplinary Studies Degree. This degree requires students to have core courses, experiences, and competencies in social science, humanities, natural sciences, mathematics, creative arts, and music. The degree requires a total of approximately 120 credit hours of BMCC classes. Students also earn their A.A.O.T. from BMCC when completing these requirements.

Education Minor. Students will complete 45 credits of education courses designed to meet Oregon state requirements for elementary licensure and upper division (300/400 level) course requirements for their multidisciplinary studies degree.

Academic Minor, Course of Study, or Endorsement Preparation. Students have several choices to fulfill the 30 credits that add to their Multidisciplinary studies degree and education course:

ESOL Endorsement area: Most CUESTE students will earn their additional required credits in the ESOL endorsement area. The ESOL program includes 15 credits of lower division (100/200 level) education related courses and 21 credits of ESOL upper division (300/400 level) courses. To add an ESOL endorsement on their Oregon teacher licensure, students must also pass the Oregon state-required ESOL exam.

Course of Study: In some cases, students may have the option of a course of study. This requires a minimum of 30 credit hours in a field of study or interest that is limited to those disciplines that are traditionally taught in elementary schools. At least 15 of the 30 credits must be upper division (330/400 level) courses. In some cases, the 15 lower division courses (100/200 level) may be part of the 120 credit hours of the multidisciplinary studies degree.

Academic Minor. This option is limited to special circumstances. It requires a minimum of 30 credit hours in a discipline area that is traditionally taught in elementary schools. The courses must meet the academic minor requirements of the particular discipline (a check list of requirements is provided for each minor). At least 15 of the 30 credits must be upper division (330/400 level) courses. In some cases, *some* the 15 lower division courses (100/200 level) may be part of the 120 credit hours of the multidisciplinary studies degree.

To receive a license to teach in Oregon, students must complete their bachelor's degree and a teacher licensure program (e.g., CUESTE) and must successfully pass the standardized tests as outlined by the Teacher Standards and Practices Commission (TSPC). For more information regarding the CUESTE program call 541-278-5802.

Medical Laboratory Technician (MLT) Program (Limited entry program)

Blue Mountain Community College has partnered with Wenatchee Valley College (WVC) in Washington State and

with Interpath Labs, a local business, to offer an associate of technical sciences degree awarded through WVC. You will be able to stay in eastern Oregon while working toward this degree. BMCC offers the program's first-year courses, and WVC offers the second-year courses through interactive television broadcast to the BMCC Pendleton campus. To meet program requirements for clinical experience, Interpath Labs works with BMCC to place students in local clinical settings.

Using state-of-the-art diagnostic equipment and procedures, medical laboratory technicians analyze blood samples in hospitals, laboratories, and clinics to determine the nature and cause of suspected illnesses. Even though the medical laboratory technician position ranks twenty-third out of 250 in a recent job satisfaction survey, there are not nearly enough MLTs to meet the nation's health care needs.

For more information about this exciting educational opportunity, visit either BMCC's Website or Wenatchee Valley's MLT site at <http://www.wvc.edu/directory/departments/medlabtech/default.asp>. You may also contact a BMCC advisor at 541-278-5876 for information.

Diagnostic Imaging

Blue Mountain Community College, Linn Benton Community College (LBCC), St. Anthony Hospital, St. Elizabeth Hospital, and Blue Mountain Hospital have partnered to offer an associate of general studies degree and a certificate in diagnostic imaging awarded through LBCC. BMCC offers the program's first-year courses, and LBCC offers academic and clinical education through a variety of learning technologies, including the Blackboard Web-based learning management system, streamed video and audio files, email, Web conferencing, and lab practice with clinical mentors. The program provides clinical education in a variety of settings and prepares the student for work as an entry-level radiologic technologist. You will be able to stay in eastern Oregon while working toward this degree.

Students prepare to practice as proficient, multi-skilled professionals in culturally diverse health care settings; to demonstrate outcomes required by the American Registry of Radiologic Technologists (ARRT) and program guidelines; and to apply for and successfully complete ARRT certification examinations.

For more information about this educational opportunity, visit <http://www.linnbenton.edu/diagnosticimaging/index.html> or contact a BMCC advisor at 541-278-5876 for information.

Career Pathways

What are Career Pathways?

Career pathways are broad categories of career options that share similar characteristics and employment requirements that call for many common interests, strengths, and competencies. There are six broad career pathways; within each of those are three to six career clusters that narrow down even further to specific career focus areas.

How do I use this information?

As early as high school, students are starting to look at career pathways to identify the classes that they need to take to prepare themselves for employment. Those same career pathways are being used by BMCC students to identify career opportunities supported by the degrees and certificates gained at BMCC.

The following information describes each of those six career pathways and gives you information to help decide whether or not that is the path for you. As you look through the BMCC catalog, you may notice the career pathway icons to which that degree or certificate is related. Use these tools to help you plan your college experience and career preparation. By having a plan, you can give purpose to your learning.



ARTS, INFORMATION, AND COMMUNICATIONS

Careers in this category are related to the humanities and the performing, visual, literary, and media arts.

Are you a creative thinker? Are you imaginative, innovative, or original? Do you like to communicate ideas? Do you like to make crafts, draw, play a musical instrument, take photos, or write stories? Then this career pathway may be for you!

We offer the following areas of emphasis to help you succeed in this career pathway:

Art
Computer Science
English
Foreign Language
Music

Speech
Theater

THE AREAS OF STUDY SHOWN IN BOLD ARE AVAILABLE TO ENHANCE YOUR TRANSFER TO A FOUR-YEAR INSTITUTION



BUSINESS AND MANAGEMENT

Careers related to the business environment include sales, marketing and advertising, computer/information systems, accounting, economics, management, and personnel.

Do you enjoy being a leader, organizing people, planning activities, and talking? Do you like working with numbers or ideas and seeing those ideas come to completion? Then this career pathway may be for you!

We offer the following areas of emphasis to help you succeed in this career pathway:

Accounting
Administrative Asst
Admin Asst—Legal
Admin Asst—Medical
Agriculture Business
Art
Business
Administration
Computer Science
Economics
English

Hospitality
Management
Mathematics
Office Assistant
Retail Management
Speech
Tourism



HUMAN RESOURCES

Careers in this category are related to economic, political, and social systems.

Do you like to work with people to solve problems? Is it important to you to do something that makes things better for other people? Do you like helping people? Then this career pathway may be for you!

We offer the following areas of emphasis to help you succeed in this career pathway:

Anthropology	Mathematics
Criminal Justice	Paraeducator
Early Childhood Education	Physical Education
Economics	Psychology
Education-Elementary	Retail Management
Education-Secondary	Sociology
English	Tourism
Foreign Language	
Geography	
Health	
History	
Hospitality Management	



INDUSTRIAL AND ENGINEERING SYSTEMS

Careers in this pathway are related to technologies necessary to design, develop, install, and maintain physical systems.

Are you mechanically inclined and practical? Do you like reading diagrams and blueprints or drawing building structures? Are you curious about how things work? Then this career pathway may be for you!

We offer the following areas of emphasis to help you succeed in this career pathway:

Chemistry	Electrician
Civil Engineering	Geography
Computer Science	Industrial Maintenance
Construction Trade	Mathematics
Diesel Technology	Plumbing
Drafting Technology	Physics



AG, FOOD, AND NATURAL RESOURCES SYSTEMS

Careers in this category are related to the environment, natural resources, and agriculture.

Are you practical or curious about the physical world, plants, and animals? Do you enjoy outdoor activities? Then this career pathway may be for you!

We offer the following areas of emphasis to help you succeed in this career pathway:

Agriculture Business	Geography
Agriculture Production	Geology
Anthropology	
Biology	



HEALTH SERVICES

Careers in this pathway are related to the promotion of health and the treatment of disease.

Do you like to care for the sick or to help them stay well? Are you interested in disease and how the body works? Do you enjoy reading about science and medicine? Then this career pathway may be for you!

We offer the following areas of emphasis to help you succeed in this career pathway:

Admin Asst—Medical	Office Asst—Medical
Biology	Physical Education
Chemistry	Pre-Dental, Med, Pharmacy, and Veterinary
Dental Assistant	Psychology
Health	
Nursing	

Degrees and Certificates

BMCC reviews and updates degree requirements annually. Please note that some of the requirements for graduation may change if your studies are interrupted by two or more years or if you take more than five years to complete a course of study. Depending upon the academic program, you may be asked to complete updated requirements in order to earn a certificate or degree.

Statement of Student Outcomes

Through the course offerings necessary to attain a degree, BMCC students will have achieved the following core competency skills:

- ✓Written and oral communication
- ✓Critical thinking and problem solving
- ✓Community, cultural, and diversity awareness
- ✓Information and technology literacy
- ✓Workplace, wellness, and ethical responsibility

To ensure the educational breadth necessary to acquire these core competencies, degree candidates must complete work in general education and other specific requirements related to each degree.

Transfer Options

ASSOCIATE OF ARTS OREGON TRANSFER (A.A.O.T.) degree, a non-designated block transfer degree designed for the student who intends to transfer to a four-year college or university within the Oregon University System (OUS). Students need to work closely with an academic advisor to plan a course of study at BMCC.

ASSOCIATE OF SCIENCE (A.S.) degree, a non-designated college transfer degree designed for students whose program requirements do not fit A.A.O.T. degree patterns. This degree does not always “block transfer” to Oregon colleges.

OREGON TRANSFER MODULE (O.T.M.), a one-year module designed to complete a portion of students’ general education requirements and is transferable to any OUS institution. Upon transfer of credits, the receiving institution may specify additional course work that is required for a major or degree requirements or to make up the difference between the O.T.M. and the institution’s total general education requirements.

This module is an excellent choice for the student who is planning to transfer to a four-year institution and either is undecided on a major or will be majoring in a program of study with specific lower division requirements that are not offered at BMCC. With the one-year module, a student can complete most general education requirements and then transfer to the four-year institution, where he or she can complete the remaining lower division requirements.

Transfer courses offered at BMCC parallel freshman

and sophomore courses offered by four-year colleges and universities. If you are planning to seek a degree at a specific four-year college or university, you should become familiar with the requirements of the proposed major program at that institution. BMCC advisors are available to assist you in this planning process.

In addition to the requirements of a major, OUS institutions require that the student earn credit hours in each of the major academic divisions: arts and letters (language, literature, and the arts), the social sciences, sciences and mathematics, and writing. These are typically referred to as general education requirements, or general university requirements. Students at BMCC who complete the A.A.O.T. as outlined will meet these OUS lower division general education requirements. Specific departmental requirements at OUS institutions can be found in the catalog of the college or university to which the student intends to transfer. OUS institutions generally will accept up to 120 credit hours of lower division course work from Oregon’s community colleges.

Degree and Certificate Options

ASSOCIATE OF APPLIED SCIENCE DEGREE (A.A.S.), awarded to students who complete the requirements of a two-year designated program as outlined in the college catalog.

ASSOCIATE OF GENERAL STUDIES DEGREE (A.G.S.), a non-designated non-transfer two-year degree that consists of both career and technical education (CTE) courses and college-transfer courses.

CERTIFICATES OF COMPLETION, awarded to students who complete the requirements of a specific curriculum of less than two academic years.

Academic Planning for the Undecided Student

A BMCC advisor can help you if you are undecided about your educational goals. BMCC offers courses and programs that can help you assess your interests and abilities as part of developing a career and academic plan. The associate of arts Oregon transfer (A.A.O.T.), associate of science (A.S.), associate of general studies (A.G.S.) degrees and Oregon transfer module (O.T.M.) offer the opportunity to explore several fields of study to help determine special interests and aptitudes. To meet with an advisor, call 541-278-5931 or email getinfo@bluecc.edu.

Transfer Options

Associate of Arts Oregon Transfer (A.A.O.T.) Degree

The associate of arts Oregon transfer (A.A.O.T.) degree is a two-year program. Students enrolled in this program must successfully complete a minimum of 90 credit hours. The A.A.O.T. degree will transfer to any Oregon University System (OUS) institution where students may complete requirements for a four-year baccalaureate degree.

The A.A.O.T. is a non-designated degree. Students planning on transferring to a four-year institution may want to choose a focus of study with the A.A.O.T. in order to meet the lower division requirements of their chosen major at the four-year institution. In that case, students should consult with their advisors to determine the additional classes recommended by that department as part or all of the 32 credits of electives indicated below. General education requirements are designed to meet the core competencies outlined by the Statement of Student Outcomes on page 34.

The following A.A.O.T. requirements are based on information available as this catalog goes to press and are subject to change. Before enrolling, students should review a current catalog or meet with an advisor of the college to which they plan to transfer to ensure course and program compatibility.

General Education Requirements	CREDITS
WR121 English Composition***	3
WR122 English Composition***	3
WR123 English Composition***	3
OR WR227 Technical Report Writing***	3
SP111 Fundamentals of Speech***	3
MTH105 Introduction to Contemporary Mathematics (or above)***	4
Arts and Letters* (selection from page 40)	12
Social Science* (selection from page 41)	15
Science with Laboratory** (selection from page 40)	12
Science/Math/Computer Science (selection from page 40)	3
Electives (Only 12 career and technical credits—selection from pages 41-44)	32
TOTAL CREDITS REQUIRED	90

*Students must choose courses from at least two disciplines (different prefixes), with no more than nine credits from one discipline (prefix).

**Students must take 12 credits in biological or physical science classes with laboratory components. Courses that meet the laboratory requirement are identified by a plus symbol on page 40 and in the Course Description section on pages 67-96 of this catalog.

***These courses must be completed with a grade of "C" or better.

- Required grade for transfer may vary by course and by accepting institution.
- Elective courses that are considered college-level transfer courses are listed on pages 41-42 and are designated by a bullet (^) in the Course Description section of this catalog.
- A maximum of 12 credits of college-level career and technical courses may be used as electives in the A.A.O.T. degree. Approved career and technical courses are listed on pages 42-44 and are designated by a bullet (>) in the Course Description section of this catalog.
- A maximum of 12 physical education activity (PE 185) credits may be counted as electives in the A.A.O.T. degree.
- A maximum of 12 pass (P) program or elective credits may count toward an A.A.O.T. degree.
- A cumulative grade point average of 2.00 or better in program required for graduation. Students transferring to a four-year college or university should check the grade point average requirement at that institution.
- Students must attend Blue Mountain Community College at least two terms and complete a minimum of 24 BMCC credits in order for BMCC to award an A.A.O.T. degree.

Associate of Science (A.S.) Degree

The associate of science degree (A.S.) is a two-year college transfer program. Students enrolled in this program must successfully complete a minimum of 90 credit hours. The A.S. will transfer to any Oregon University System (OUS) institution but does not always “block transfer,” nor will it necessarily complete the general education requirements of that university.

The A.S. is a non-designated degree. Students planning to transfer to a four-year institution may want to choose a focus of study with the A.S. in order to meet the lower division requirements of their chosen major at the four-year institution. In that case, students should consult with their advisors to determine the additional classes recommended by that department as part or all of the 44 credits of electives indicated below. General education requirements are designed to meet the core competencies outlined by the Statement of Student Outcomes on page 34.

The following A.S. degree requirements are based on information available as this catalog goes to press and are subject to change. Before enrolling, students should review a current catalog of the college to which they plan to transfer to ensure course and program compatibility.

General Education Requirements	CREDITS
WR121 English Composition*	3
WR122 English Composition*	3
SP111 Fundamentals of Speech*	3
MTH105 Introduction to Contemporary Mathematics (or above)*	4
CS 120 Introduction to Computers (or above)*	4
HLTH/PE Health/Fitness Courses*	3
Arts and Letters (selection from page 40).....	9
<i>Sequence highly recommended. First-year foreign language courses may not be used to meet this requirement.</i>	
Social Science (selection from page 41).....	9
<i>Sequence highly recommended.</i>	
Science with Laboratory (selection from page 40)	4
Science/Math/Computer Science (selection from page 40).....	4
Electives (Only 12 Career and Technical Credits/selection from pages 42-44) ...	44
TOTAL CREDITS REQUIRED	90

* These courses must be completed with a grade of “C” or higher.

The above **arts and letters** course requirements are in addition to the writing requirements.

Required grade for transfer may vary by course and by accepting institution.

- A maximum of 12 physical education activity (PE 185) credits may be counted as electives in the A.S. degree.
- A maximum of 12 pass (P) program or elective credits may count toward an A.S. degree.
- A cumulative grade point average of 2.00 or better in program required for graduation. Students transferring to a four-year college or university should check the grade point average requirement at that institution.
- Students must attend Blue Mountain Community College at least two terms and complete a minimum of 24 BMCC credits in order for BMCC to award an A.S. degree.

Oregon Transfer Module

The Oregon transfer module (OTM) is a one-year module designed for transfer to any college or university in the Oregon University System. Upon transfer, the receiving institution may specify additional coursework that is required to complete major or degree requirements or to make up the difference between the OTM and the institution's total general education requirements.

The module is 45 credits, the equivalent of three academic quarters. The course work must be chosen from courses approved for the A.A.O.T. degree. All courses must be passed with a grade of C or better and must be courses of 3 or more credits (quarter system). Students must have a minimum cumulative GPA of 2.00 at the time the module is posted.

This module is an excellent choice for the student who is planning to transfer to a four-year institution and either is undecided on a major or will be majoring in a program of study with specific lower division requirements that are not offered at BMCC. With the one-year module, a student can complete the majority of his or her general education requirements and then transfer to the four-year institution to complete the remaining lower division requirements.

Foundation Skills:	CREDITS
WR 121 English Composition.....	3
WR 122 English Composition.....	3
SP 111 Fundamentals of Speech.....	3
MTH 105 Introduction to Contemporary Math (or above).....	4
Introduction to Disciplines:	
Arts and Letters (Humanities).....	9
Social Sciences	9
Science/Math/Computer Science	10-12
Electives.....	2-4
TOTAL CREDITS	45

Science/Math/Computer Science must include at least one biological or physical science with a lab. Electives must be chosen from the "Introduction to Discipline" areas.

NOTE: Students indicating the O.T.M. as their only degree intent are not eligible for financial aid.

Transfer courses parallel freshman and sophomore courses offered by four-year colleges and universities. Students normally transfer at the end of the sophomore year to junior standing at the school of their choice.

BMCC offers credits transferable to four-year colleges and universities. Students planning to seek a degree at a specific four-year college or university should familiarize themselves with the requirements of the proposed major program at that college or university. BMCC advisors are available to assist students in this planning process.

In addition to the requirement of the major, OUS institutions require that the student earn credit hours in each of the major academic divisions: arts and letters (language, literature, and the arts), the social sciences, sciences and mathematics, and writing. These are typically referred to as general education requirements, or general university requirements. Students at BMCC who complete the A.A.O.T. as outlined will meet these OUS lower division general education requirements. Specific departmental requirements at OUS institutions can be found in the catalog of the college or university to which the student intends to transfer. OUS institutions generally will accept up to 120 credit hours of lower division course work from Oregon's community colleges.

College Transfer Courses

Arts and Letters (Humanities)

Art	Credits
ART 101, 102, 103 Introduction to Visual Arts	3 each
ART 115, 116, 117 Basic Design	3 each
ART 131, 132, 133 Beginning Drawing	3 each
ART 154, 155, 156 Beginning Ceramics	3 each
ART 184, 185, 186 Watercolor	3 each
ART 204, 205, 206 History of Western Art	3 each
ART 222, 223 Graphic Design	3 each
ART 231, 232, 233 Intermediate Drawing	3 each
ART 254, 255, 256 Intermediate Ceramics	3 each
ART 261, 263 Beginning Photography	3 each
ART 262 Digital Photo Imaging	3
ART 264, 265, 266 Intermediate Photography	3 each
ART 276, 277, 278 Beginning Sculpture	3 each
ART 281, 282, 283 Beginning Painting	3 each
ART 284, 285, 286 Intermediate Painting	3 each
ART 291, 292, 293 Intermediate Sculpture	3 each

English	Credits
ENG 104, 105, 106 Introduction to Literature	3 each
ENG 107, 108, 109 World Literature	3 each
ENG 195, 196, 197 Film as Literature	3 each
ENG 201, 202, 203 Shakespeare	3 each
ENG 204, 205, 206 Survey of English Literature	3 each
ENG 214 Myth in Oregon Literature	3
ENG 240 Native American Literature	3
ENG 253, 254, 255 Survey of American Lit	3 each
ENG 260 Introduction to Women Writers	3
ENG 263, 264 Detective Fiction	3 each
WR 121, 122, 123 English Composition	3 each
WR 227 Technical Report Writing	3
WR 241, 242, 243 Introduction to Imaginative Writing	3 each

Foreign Languages	Credits
SPAN 201, 202, 203 Second-Year Spanish	4 each

Music	Credits
MUS 105 Music Appreciation	3
MUS 111, 112, 113 Music Theory	4 each
MUS 201, 202, 203 Intro to Music and Its Literature	3 each
MUS 205 Introduction to Jazz History	3
MUS 206 History of Rock Music	3
MUS 207 History of Folk Music	3
MUS 211, 212, 213 Music Theory	3 each

Philosophy	Credits
PHL 101, 102, 103 Introduction to Philosophy	3 each

Speech	Credits
SP 111, 112, 113 Fundamentals of Speech	3 each
SP 115 Intercultural Communication	3
SP 237 Gender and Communication	3

Theater	Credits
TA 101 Introduction to the Theater	3
TA 141, 142, 143 Fund of Acting Techniques	3 each

Science/Mathematics/ Computer Science

Science	Credits
<i>(+ = courses meeting the laboratory science requirement)</i>	
+ BI 101, 102, 103 General Biology	4 each
+ BI 124 Global Ecology and Conservation Biology	4
BI 149 Human Genetics	3
+ BI 162 Selected Topics in Natural History	4
+ BI 163 Natural History of Oregon	4
+ BI 211, 212, 213 General Biology	5 each
+ BI 231, 232, 233 Human Anat and Physiology	4 each
+ BI 234 Microbiology	4
+ BOT 221 Systematic Botany	4
+ CH 104, 105, 106 Elementary Chemistry	5 each
+ CH 121, 122, 123 College Chemistry	5 each
+ CH 221, 222, 223 General Chemistry	5 each
+ CH 241, 242, 243 Organic Chemistry	5 each
+ G 101, 102, 103 Introduction to Geology	4 each
G 145 Geology of the Pacific Northwest	3
G 146 Rocks and Minerals	3
G 147 Basic Geology	3
+ G 201, 202 Physical Geology	4 each
+ G 203 Historical Geology	4
GEOG 101 Physical Geography	3
+ GS 104 Physical Science/Physics	4
+ GS 105 Physical Science/Chemical Concepts	4
+ GS 107 Physical Science/Astronomy	4
+ GS 110 Physical Science/Energy	4
+ GS 111 Physical Science/Forensic Science	4
+ GS 142 Physical Geology/Earth Revealed	4
+ PHY 101 Essentials of Physics	4
+ PHY 201, 202, 203 General Physics	5 each
+ PHY 211, 212, 213 Gen. Physics with Calculus	5 each

Mathematics	Credits
MTH 105 Introduction to Contemporary Math	4
MTH 111 College Algebra	4
MTH 112 Elementary Functions	4
MTH 211, 212, 213 Foundations of Elementary Math	4 each
MTH 231 Discrete Mathematics*	4
MTH 241 Calculus for Management/Social Science	4
MTH 243 Introduction to Probability and Statistics	4
MTH 251, 252, 253 Calculus	4 each
MTH 254, 255 Vector Calculus*	4 each
MTH 256 Differential Equations*	4
MTH 261 Linear Algebra*	4

Computer Science	Credits
CS 120, Concepts of Computing	4 each
CS 133B Programming with Visual BASIC	4
CS 133U Programming with C++	4
CS 161, 162 Computer Science	4 each
CS 195 Web Development	4
CS 260 Data Structures*	4
CS 295 Web Development	4

Social Science

Anthropology

	Credits
ANTH 101 Introduction to Physical Anthropology	3
ANTH 102 Introduction to Archaeology and Prehistory	3
ANTH 103 Introduction to Cultural Anthropology	3

Economics

	Credits
EC 201 Principles of Economics/Microeconomics	3
EC 202 Principles of Economics/Macroeconomics	3
EC 203 Principles of Economics/Theory	3

Geography

	Credits
GEOG 103 Human Geography	3
GEOG 106, 107 Human and Cultural Geography	3 each
GEOG 120 World/Regional Geography	3
GEOG 140 Map Reading and Interpretation	3
GEOG 206 Geography of Oregon	3

History

	Credits
HST 101, 102, 103 History of Western Civilization	3 each
HST 104, 105, 106 World Civilizations	3 each
HST 201, 202, 203 History of the United States	3 each
HST 205 Women of the West	3
HST 258, 259 History of Latin America	3 each

Political Science

	Credits
PS 201, 202 American Government and Politics	3 each
PS 203 American Government/State and Local	3
PS 206 Politics of Western Europe and Russia	3

Psychology

	Credits
PSY 201, 202, 203 General Psychology	3 each
PSY 231 Human Sexuality	3
PSY 237 Human Development	3

Sociology

	Credits
*ES 211 Chicano/Latino Historical Experience	3
*ES 212 Chicano/Latino Political, Econ and Soc Issues	3
SOC 204, 205 General Sociology	3 each
SOC 206 General Sociology/Problems and Issues	3
SOC 213 Minorities	3
SOC 217 Family and Society	3
SOC 221 Juvenile Delinquency	3

* Course offered irregularly.

A.A.O.T. Electives

All courses listed above and those listed below satisfy the A.A.O.T. degree elective requirements.

All courses numbered 198,298 Special Studies and 199,299 Experimental Courses will be accepted as AAOT electives.

	Credits
ART 154, 155, 156 Beginning Ceramics	3 each
ART 184, 185, 186 Watercolor	3 each
BA 101 Introduction to Business	4
BA 131 Introduction to Business Computing	4
BA 206 Principles of Management	4

BA 207 E-Commerce	4
BA 211, 212, 213 Principles of Accounting	4 each
BA 214 Business Communications	3
BA 226 Business Law	4
BA 280 Cooperative Work Experience	1 - 8
CJ 100 Survey of Criminal Justice	3
CJ 101 Introduction to Criminology	3
CJ 107 Criminal Justice Seminar	3
CJ 110 Introduction to Law Enforcement	3
CJ 111 Concepts of Enforcement Services	3
CJ 114 Gender, Race, Class and Crime	3
CJ 115 Culture of Guns and Violence in America	3
CJ 120 Judicial Process	3
CJ 122 Oregon Law	3
CJ 130 Introduction to Corrections	3
CJ 132 Introduction to Probation and Parole	3
CJ 200 Police and Public Policy	3
CJ 201 Juvenile Delinquency	3
CJ 204 Behavioral Cognitive Processes in Corrections	4
CJ 207 Community Policing	3
CJ 210 Criminal Investigation	3
CJ 215 Criminal Justice Administration	3
CJ 220 Criminal Law	3
CJ 222 Criminal Procedure & Evidence	3
CJ 225 Correctional Law	3
CJ 226 Constitutional Law	3
CJ 232 Introduction to Correctional Casework	3
CJ 243 Narcotics and Dangerous Drugs	3
CJ 280 Cooperative Work Experience	1 - 8
CS 125 Software Applications	1 - 3
CS 280 Cooperative Work Experience	1 - 8
ECE 245 Challenging Behavior in Young Children	3
ED 100 Introduction to Education	1
ED 125 Tutor Certification	1
ED 200 Foundations in Education	3
ED 280 Cooperative Work Experience	1 - 8
ENG 280 Cooperative Work Experience	1 - 8
FN 225 Nutrition	4
GS 160 Observational Astronomy	3
HD 100 College Survival and Success	3
HD 109 Academic Planning	1
HD 110 Career Planning	2
HD 151, 152, 153 Service Leadership	1 each
HD 154, 254 Ambassadorship	1 each
HD 204 Self-Motivation and Personal Potential	3
HD 206 Coping Skills for Stress	3
HE 115 Body Composition Assessment	1
HE 250 Personal Health	3
HE 252 First Aid	3
HE 253 Personal Nutrition	3
HPE 295 Health and Fitness for Life	3
MS 101 Intro to Leadership & Personal Development	2
MTH 103 Problem Solving with Technology*	1
MTH 280 Cooperative Work Experience	1 - 8
MUP 105, 205 Jazz Ensemble	2 each quarter
MUP 115, 215 General Ensemble	2 each quarter
MUP 122, 222 Concert Choir	2 each quarter
MUP 125, 225 Vocal Jazz Ensemble	2 each quarter
MUP 141, 241 Symphony Orchestra	1 each
MUP 168, 169, 170, 171, 173, 174, 191, 192, 268, 269, 270, 271, 273, 274, 291, 292 Applied Woodwinds, Brass, Strings, Piano, Organ, Voice, Percussion	1 each

MUS 101 Fundamentals of Music	2	ANS 220 Beef Production	4
MUS 107, 108, 109 Studio Recording Technician	2 each	ANS 221 Horses and Horsemanship	3
MUS 131, 132, 133 Class Piano	2 each	ANS 222 Sheep and Swine Production	4
MUS 135 Class Voice	2	ANS 231 Livestock Evaluation	3
PE 131 Introduction to Physical Education	3	ANS 232 Livestock Evaluation	3
PE 185 All PE 185 courses. (Max. of 12 credits)	1 each	ANS 233 Livestock Evaluation/Oral Reasons	1
PE 280 Cooperative Work Experience	1 - 8	ANS 240 Animal Health	5
PE 290 Lifeguard Training Review	1 - 8	APR110A Plumbing Apprenticeship Fundamentals	4
PE 291 Lifeguard Training	2	APR110B Plumbing App Math & Basic Installations	4
PE 292 Water Safety Instructor/WSI	2	APR110C Plumbing Apprenticeship Print Reading	4
PE 293 Lifeguard Instructor Training/LGI	2	APR110D Plumbing Apprenticeship Installation	4
PS 222 Public Policy	3	APR110E Plumbing Apprenticeship Occupancy	4
PSY 101 Psychology and Human Relations	3	APR110F Plumbing Apprenticeship Advanced Water Sys	4
PSY 119 Process in Living	3	APR111A LMPE Apprenticeship Fundamentals	4
RD 120 Critical Reading & Thinking	3	APR111B LMPE Apprenticeship AC/DC CIRCUITS	4
SOC 243 Narcotics & Dangerous Drugs	3	APR111C LMPE Apprenticeship Measurements	4
SP 100 Human Communications	3	APR111D LMPE Apprenticeship Theory	4
SP 229 Oral Interpretation	3	APR111E LMPE Apprenticeship Wiring & Print	4
SPAN 101, 102, 103 First-Year Spanish	4 each	APR111F LMPE Apprenticeship Installation	4
SPAN 211, 212, 213 Spanish Conver and Comp	3 each	APR112A Inside Electrical App Fundamentals	4
TA 165 Technical Theater Workshop	1 - 3	APR112B Inside Electrical App AC/DC Circuits	4
TA 180 Theater Rehearsal and Performance	3	APR112C Inside Electrical Apprenticeship Measure	4
TA 241, 242, 243 Intermediate Acting Techniques	3 each	APR112D Inside Electrical Apprenticeship Theory	4
WR 115 Introduction to College Writing	3	APR112E Inside Electrical App Wiring & Print	4
		APR112F Inside Electrical App. Installation	4
		APR114A PLC Apprenticeship Hardware/Numbering System	4
		APR114B PLC Apprenticeship Programming Fundamentals	4
		APR114C PLC Apprenticeship Timers/Counters/Controls	4
		APR115A LME Apprenticeship Fundamentals	4
		APR115B LME Apprenticeship AC/DC Circuits	4
		APR115C LME Apprenticeship Measurement Blueprint	4
		APR210G Plumbing Apprenticeship Residential Installation	4
		APR210H Plumbing Apprenticeship Commercial Installation	4
		APR210I Plumbing Apprenticeship Code	4
		APR210J Plumbing Apprenticeship Industrial Installation	4
		APR210K Plumbing Apprenticeship Basic Waste Water	4
		APR210L Plumbing Apprenticeship Code & Test Prep	4
		APR211G LMPE Apprenticeship Safety & Code	4
		APR211H LMPE Apprenticeship Motors & Controls	4
		APR211I LMPE Apprenticeship FIBER OPTICS	4
		APR211J LMPE Apprenticeship Math & Test	4
		APR211K LMPE Apprenticeship Voltage	4
		APR211L LMPE Apprenticeship Math & Test Prep	4
		APR212G Inside Electrical App Safety & Code	4
		APR212H Inside Electrical Apprenticeship Motor/Col	4
		APR212I Inside Electrical Apprenticeship Fiber Ops	4
		APR212J Inside Electrical Apprenticeship Math/Test	4
		APR212K Inside Electrical Apprenticeship Voltage	4
		APR212L Inside Electrical App Code & Test Prep	4
		APR214D PLC Apprenticeship Sequences	4
		APR214E PLC Apprenticeship Troubleshooting	4
		APR214F PLC Apprenticeship Practical Application	4
		APR215D LME Apprenticeship Safety & Code	4

•Course offered irregularly.

A.A.O.T. Career and Technical Electives

A maximum of 12 credits of the career and technical courses listed below may also be used to satisfy the A.A.O.T. degree elective requirements.

All courses numbered 198,298 Special Studies and 199,299 Experimental Courses will be accepted as career and technical electives.

	Credits		
AGM 131 Agriculture Safety	3		
AGM 140 Agriculture Engines	3		
AGM 211 Agriculture Business Management	4		
AGM 221 Metals and Welding	3		
AGM 241 Agriculture Machinery	3		
AGM 249 Advanced Agricultural Shop	2		
AGM 250 Irrigation Systems Design	3		
AGM 251 Irrigation Systems	3		
AGR 101 Agriculture Orientation	1		
AGR 111 Agriculture Computers	3		
AGR 200 Pre-Employment	1		
AGR 210 Agriculture Accounting	4		
AGR 211 Agriculture Business Management	3		
AGR 221 Agriculture Marketing	3		
AGR 226 Agriculture Issues	3		
AGR 280 Cooperative Work Experience	1 - 8		
AGR 296 Production Problems	4		
ANS 121, 122 Animal Science	3 each		
ANS 198 Animal Science Reproduction Clinic	1		
ANS 201 Introduction to Equine Science	3		
ANS 211 Animal Nutrition	4		
ANS 212 Animal Nutrition Recitation	1		
ANS 216 Pregnancy Testing/Bovine	1		
ANS 217 Artificial Insemination	3		
ANS 218 Advanced Artificial Insemination	1		

APR215E LME Apprenticeship Motors & Controls	4	CET 235 Structures	4
APR215F LME Apprenticeship Code & Test Prep	4	CET 242 Structures	4
BA 104, 105 Business Mathematics	4 each	CET 251 Estimating Construction Costs	4
BA 110A Business Computer Applications/MS Access	3	CET 261 Hydraulics	4
BA 110X Business Computer Applications/MS Excel	3	CET 263 3-D Computer Aided Drafting	3
BA 111 Basic Accounting	4	CET 280 Cooperative Work Experience	1 - 8
BA 131 Introduction to Business Computing	4	CSS 100 Soils and Fertilizers	3
BA 155 Introduction to Fraud Examination	3	CSS 201 Principles of Crop Science	3
BA 177 Payroll Accounting	4	CSS 210 Forage Crops	3
BA 207 E-Commerce	4	CSS 240 Pest Management	4
BA 209A Accounting Applications	3	DA141 Dental Radiology	4
BA 209P Accounting Applications/Payroll	3	DA142 Dental Radiology	3
BA 209Q Accounting Applications/QuickBooks	3	DA143 Dental Radiology	1
BA 210 Microcomputer Applications/Advanced Excel	3	DA151 Chairside Procedures	3
BA 215 Cost Accounting	3	DA152 Chairside Procedures	3
BA 220 Tax Accounting	3	DA153 Chairside Procedures	2
BA 221 Accounting Problems/Tax	4	DA154 Dental Specialties	2
BA 223 Principles of Marketing	4	DA161 Clinical Practice	2
BA 224 Human Resources Management	3	DA162 Clinical Practice	4
BA 249 Retail Selling	3	DA163 Clinical Practice	8
BA 261 Intermediate Accounting	4	DA166 Clinical Practice Seminar	1
BA 262 Intermediate Accounting	4	DA170 Basic Dental Science	3
BA 263 Intermediate Accounting	4	DA172 Dental Anatomy	4
BA 265 Accounting Problems	4	DA174 Dental Pathology	1
BA 268 Introduction to Auditing	3	DA176 Dental Pharmacology	1
BA 284 Pre-Employment Seminar	1	DA180 Dental Materials	3
BA 285 Human Relations in Business	3	DA182 Dental Materials & Procedures	2
BT 116 Office Procedures	3	DA190 Dental Health Education	2
BT 120 Computer Keyboarding	2	DA192 Dental Law & Ethics	1
BT 121, 122, 123 Keyboarding	3 each	DA194 Dental Business Office	3
BT 124 Keyboarding	3	DA196 Medical Emergencies in the Dental Office	1
BT 131 Legal Office Procedures	3	DSL141 Heavy Duty Steering & Suspension	4
BT 140 Business Document Editing	3	DSL151 Heavy Duty Brakes	3
BT 201M Word Processing/MS Word	3	DSL152 Manual Drive Transmission I	3
BT 202M Word Processing/MS Word	3	DSL153 Manual Drive Transmission II	3
BT 206 Desktop Publishing	3	DSL161 Diesel Engines	3
BT 220 Calculating Machines	3	DSL162 Engine Repair I	3
BT 225 Machine Transcription	2	DSL175 Heavy Equipment	3
BT 230 Legal Terminology	3	DSL176 Mobile Air Conditioning & Heating	3
BT 251 Medical Terminology	3	DSL181 Shop Practices	3
BT 252 Medical Terminology	3	DSL184 Applied Fluid Mechanics	4
BT 253 Medical Transcription	3	DSL191 Electrical Systems I	4
BT 254 Medical Transcription	3	DSL192 Electrical Systems II	4
BT 257 Medical Office Procedures	3	DSL193 Electrical Systems III	4
BT 258 Medical Insurance Procedures and Coding	3	DSL196 Diesel Electronics Electron Diagnostics	3
BT 280 Cooperative Work Experience	1 - 8	DSL241 Frames, Couplings & Trailers	3
BT 290 Integrated Office Systems	3	DSL251 Heavy Duty Brakes II	3
CET 111 Introduction to Engineering Technology	3	DSL262 Engine Repair II	3
CET 112 Computer Aided Drafting	3	DSL280 CWE: Diesel	1 - 8
CET 113 Advanced Computer Aided Drafting	3	ECE 100 Developmentally Appropriate Practice	3
CET 114 Intro to Geographic Information Systems	3	ECE 101 Family and Community Relations	3
CET 145 Engineering Graphics	3	ECE 111 Introduction to ECE/Environments	3
CET 152 Materials of Construction	2	ECE 112 Introduction to ECE/Professionalism	1
CET 162 Engineering Materials	3	ECE 113 Introduction to ECE/Child Advocacy	1
CET 205 Structural Drafting	3	ECE 150 Observation/Assessment and Recording	3
CET 215 Contract Documents	4	ECE 151 Guidance and Classroom Management	3
CET 222 Concrete Practices	4	ECE 152 Creativity for Young Children	3
CET 222A Concrete Field Testing	1	ECE 153 Music and Movement for Young Children	3
CET 222B Concrete Control Technician	2	ECE 154 Literature and Literacy	3
CET 222C Concrete Strength Testing Technician	1	ECE 161 Infant/Toddler Practicum	4
CET 223 Soil Mechanics	3	ECE 163 Preschool/ Practicum	4
CET 231 Structures	4	ECE 175A Infant/Toddler Care giving: Soc Emotional	1

ECE 175B Infant/Toddler Care giving: Group Care	1	PHC 212 Pharmacology	2
ECE 175C Infant/Toddler Care giving: Cognitive Dev.	1	RNG 241 Range Management	3
ECE 175D Infant/Toddler Care giving: Culture/Family	1	SUR 161 Plant Surveying	5
ECE 226 Child Development	3	SUR 162 Surveying & Mapping	5
ECE 227 Enhancing Social-Emotional Development	3	SUR 166 Highway Fundamentals	3
ECE 240 Curriculum/Planning	3	SUR 167 Surveying Seminar	3
ECE 245 Challenging Behavior in Young Children	3	WLD 111 Basic Gas & Arc Welding	3
ECE 248 Overview of Special Services	3	WLD 112 Advanced Arc Welding	3
ECE 249 Inclusion of Children with Special Needs	3	WLD 221 TIG Welding	3
ECE 258 Multicultural Education	3	WLD 253 Welding Practices for Certification	3
ECE 280 Cooperative Work Experience	1 - 8	WLD 256 Pipe Welding for Certification	3
ECE 295 Child Care Administration	3		
ECE 296 Issues and Trends in ECE	3		
ED 101 Introduction to Observation and Experience	3		
ED 113 Instructional Strategies in Language Arts	3		
ED 114 Instructional Strategies in Math and Science	3		
ED 130 Comprehensive Classroom Management	3		
ED 131 Instructional Strategies	3		
ED 169 Overview of Students with Special Needs	3		
ED 229 Learning and Development	3		
ED 235 Educational Technology	3		
ED 254 Instructional Strategies for ELL	3		
ED 258 Multicultural Education	3		
ED 266 Current Issues in Special Education	3		
ED 268 Educating Mildly and Severely Handicapped	3		
ED 285 Signing Exact English	3		
ED 286 Signing Exact English	3		
ED 287 Signing Exact English	3		
FN 230 Children, Families and Nutrition	3		
GAM225 Introduction to Gaming Management	4		
GEOG 140 Map Reading and Interpretation	3		
HORT 100 Plant Science	3		
HORT 111 Alternative Crop Production	3		
HTM 100 Introduction to the Hospitality Industry	3		
HTM 101 Customer Service Management	3		
HTM 102 Hotel, Restaurant and Travel Law	3		
HTM 103 Marketing in the Hospitality Industry	3		
HTM 104 Travel and Tourism Industry	3		
HTM 105 Intro to the Food and Beverage Industry	3		
HTM 107 Food Sanitation and Cost Control	3		
HTM 109 Introduction to the Lodging Industry	3		
HTM 112 Bed and Breakfast Management	3		
HTM 124 Catering and Banquet Operations	3		
HTM 126 Meeting and Convention Management	3		
HTM 127 Selling in the Hospitality Industry	3		
HTM 130 Beverage Management	3		
HTM 132 Menu Engineering	3		
NUR 101 Fundamentals of Nursing	9		
NUR 102 Medical-Surgical Nursing	9		
NUR 103 Medical-Surgical Nursing	13		
NUR 115 Nursing Skills Laboratory	1		
NUR 161 Nursing Skills Laboratory	1		
NUR 171 Nursing Skills Laboratory	1		
NUR 201 Advanced Medical Surgical Nursing	11		
NUR 202 Maternal, Neonatal and Women's Health	11		
NUR 203 Psychiatric/Community Health	11		
NUR 254 Health Assessment	3		
NUR 296 RN Review	1		
NUR 280 Cooperative Work Experience	1 - 8		
PHC 211 Pharmacology	2		

Computer Literacy approved course list

(Refer to page 15 for more information)

AGR 111 Agriculture Computers	3
BA131 Introduction to Business Computing	4
CS120 Concepts of Computing	3
ED235 Education Technology	3

Writing Progression Chart

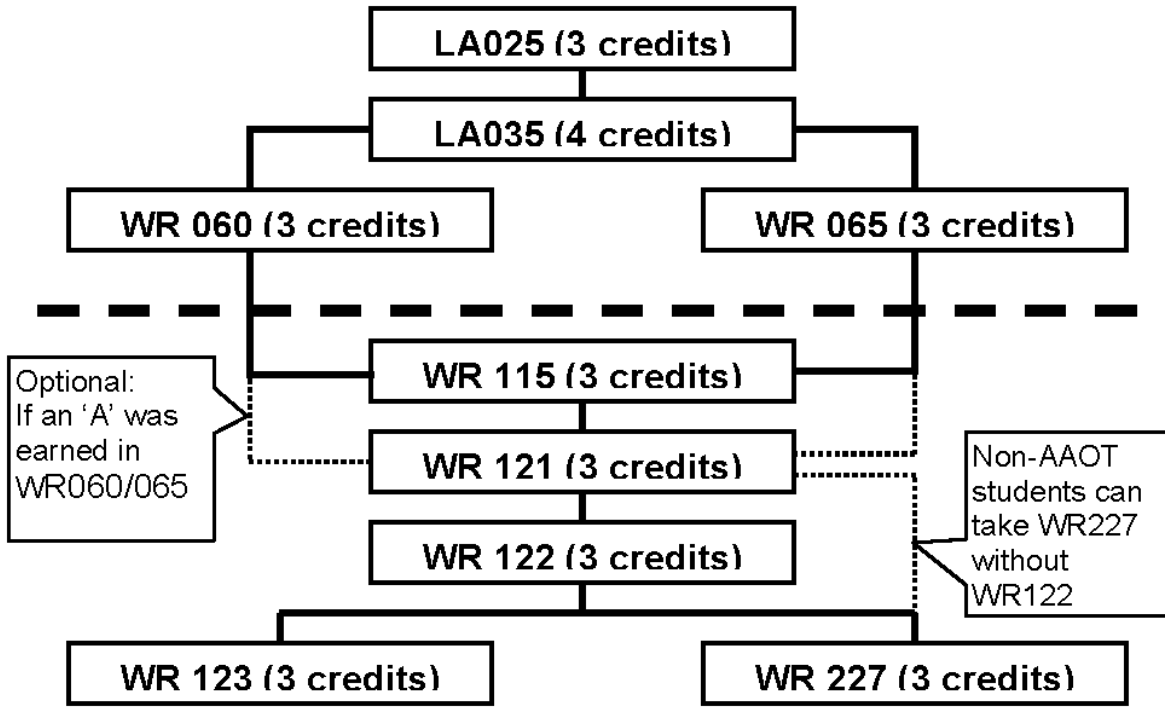

Math Progression Chart

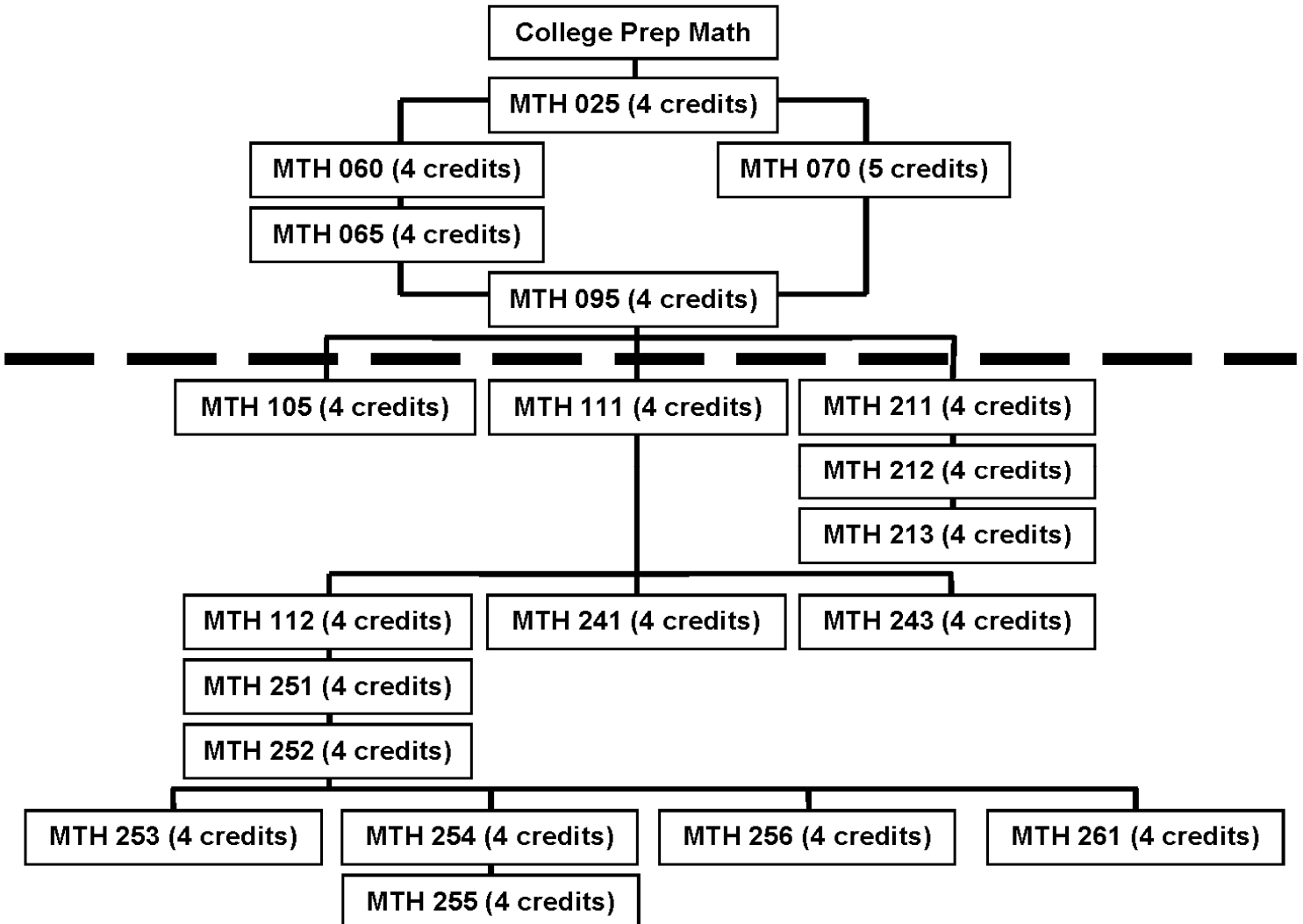

Degree and Certificate Options

Associate of Applied Science (A.A.S.) Degrees

These degrees are two-year designated career and technical programs requiring a minimum of 93 credits. Each degree listed on the following pages includes program requirements and general education requirements designed to meet core competencies that meet state requirements for writing, speech, mathematics/computer science, human relations, and general education.

General A.A.S requirements include:

Communications:

Writing (WR 060—WR 227 or BA214)..... 3 - 9 Credits

Speech (SP 100—SP 115) 3 - 9 Credits

Computation:

Mathematics/Computer Science..... 3 - 9 Credits

MTH 025 or higher or BA104, BA105

CS 120 or above or BA131

Human Relations: 3 - 9 Credits

Arts and Letters (except Speech) or Social Science

Courses selected from page 40 and 41 and/or BA 285, HD 100, RD 120

MINIMUM GENERAL EDUCATION REQUIREMENTS..... 18 Credits

Degree Program Requirements

Refer to specific program descriptions in the catalog for course selection and minimum requirements.

TOTAL MINIMUM CREDIT REQUIREMENT **93 Credits**

- A maximum of 12 pass (P) program or elective credits may count toward an A.A.S. degree.
- A cumulative grade point average of 2.00 or better in program required for graduation.
- Students must attend Blue Mountain Community College at least two terms and complete a minimum of 24 BMCC credits in order for BMCC to award an A.A.S. degree.

See the degree descriptions on the following pages for program specific recommendations. Program requirements are subject to change, so please consult an advisor.



A.A.S./Accounting



Business and Management

Intended Program Outcomes:

This two-year program leading to an A.A.S. degree in accounting offers students the opportunity to develop an advanced understanding of accounting principles. Learning experiences in this program are designed to assist the student in realizing the following outcomes:

- Use of current computer technologies, especially spreadsheet and accounting software, to perform the duties within a business setting.
- Balance and reconcile financial information to ensure accuracy of information.
- Analyze financial data in order to understand it and to use the data to make decisions.
- Use reconciliation processes when working with data to identify and correct errors
- Prepare professional financial statements and other reporting documents.
- Preparation for licensure process within the state of Oregon to prepare tax returns.
- Ability to effectively seek and respond to accounting-related opportunities for increased responsibilities and professional advancement.
- Understand the various business functions as they contribute to the success of an organization

Employment possibilities include bookkeeper, accounting clerk, payroll clerk, accounting associate, cost accountant, financial accountant or tax accountant. Jobs are available in business, industry, government agencies, service industries and banks.

At least 99 credit hours of course work must be satisfactorily completed in order to receive this degree.

CREDITS

BA 101 Introduction to Business	4
BA 104 Business Mathematics	4 OR
MTH095 Intermediate Algebra or higher	4
BA 105 Business Mathematics	4 OR
MTH095 Intermediate Algebra or higher	4
BA 110X Business Computer Apps/MS Excel	3
BA 131 Introduction to Business Computing	4
BA 177 Payroll Accounting	4
BA 155 Introduction to Fraud.....	3
BA 206 Principles of Management.....	4
BA 209A Computerized Accounting Applications	3 OR
BA 209Q Accounting Apps/QuickBooks	3
BA 210 Business Computer Applications /Adv Excel	3
BA 211 Principles of Accounting	4
BA 212 Principles of Accounting	4
BA 213 Principles of Accounting	4
BA 215 Cost Accounting	4
BA 220 Tax Accounting	4
BA 221 Accounting Problems/Tax	4
BA 226 Business Law	4
BA 261 Intermediate Accounting	4
BA 262 Intermediate Accounting	4
BA 263 Intermediate Accounting	4
BA 265 Accounting Problems	4
BA 268 Introduction to Auditing	3
BA 284 Pre-Employment Seminar	1
BA 285 Human Relations in Business	3
BT 220 Calculating Machines	3
HTM 101 Customer Service	3
SP 111 Fundamentals of Speech	3
WR 121 English Composition	3

Note: Students enrolled in this curriculum should contact their business advisor for approved electives.

A.A.S./Administrative Assistant



Business and Management

Intended Program Outcomes:

This program leading to an A.A.S. degree in administrative assistant offers students the opportunity to develop top-level office skills. Learning experiences in this program are designed to assist the student in realizing the following outcomes:

- Use current and emerging word processing technologies to produce organizational documents and presentation materials.
- Meet or exceed the current speed and accuracy requirements for typing and 10-key operation in the industry.
- Individually and collaboratively manage multiple office tasks, prioritizing and reprioritizing in response to changing demands.
- Assess the image that is expected of office personnel in a specific industry group; reflect those expectations in personal appearance, professional, conduct, and personal hygiene.
- Produce clear, concise, and mechanically correct written documents.
- Model effective customer service interactions.
- Seek and respond to opportunities for increased responsibilities and professional advancement.
- Understand office functions as they contribute to sound business practices and procedures.
- Perform the general office procedures of filing, equipment operation, mail distribution, phone calls, and tasks requiring basic math calculations (like inventory).

At least 99 credit hours of course work must be satisfactorily completed in order to receive this degree.

CREDITS

BA 101 Introduction to Business	4
BA 104 Business Mathematics.....	4OR
MTH095 Intermediate Algebra or higher	4
BA 110A Business Computer Applications/Access.....	3
BA 110X Business Computer Apps/MS Excel	3
BA 131 Introduction to Business Computing	4
BA 177 Payroll Accounting	4
BA 206 Principles of Management	4
BA 207 E-Commerce.....	4
BA 209Q Accounting Applications/QuickBooks	3
BA 210 Advanced Excel	3
BA 211 Principles of Accounting	4
BA 214 Business Communications	3
BA 277 Business Ethics	3
BA 284 Pre-Employment Seminar	1
BA 285 Human Relations in Business	3
HTM 101 Customer Service.....	3
HTM 126 Meeting & Convention Management.....	3
BT 116 Office Procedures.....	3
BT 121 Keyboarding	3
BT 122 Keyboarding	3
BT 123 Keyboarding	3
BT 124 Applied Keyboarding	3
BT 140 Business Document Editing	3
BT 201M Word Processing Procedures/Word	3
BT 202M Word Processing Procedures/Word	3
BT 206 Desktop Publishing	3
BT 220 Calculating Machines.....	3
BT 225 Machine Transcription	2
BT 280 Cooperative Work Experience	2
BT 290 Integrated Office Systems	3
SP 111 Fundamentals of Speech	3
WR 121 English Composition.....	3

Note: Students enrolled in this curriculum should contact their business advisor for approved electives.

A.A.S./Administrative Assistant: Legal Option



Business and Management

Intended Program Outcomes:

This two-year program leading to an A.A.S. in administrative office assistant, legal option, provides students with the specialized skills necessary for employment as legal administrative assistants.

Students will be effective in the workplace in the following areas:

- Use of appropriate legal terminology with written and oral accuracy,
- Use of transcription machines effectively to produce legal documents,
- Office bookkeeping and general accounting tasks,
- Effective use of database and spreadsheet software,
- Understanding of the legal system.

Students have the opportunity to develop top-level office skills in various computer applications, formatting specialized legal documents, dictation using word processing equipment, as well as the ability to prioritize. Employment possibilities include private and public legal and criminal justice offices, courtrooms, and various criminal justice facilities.

At least 100 credit hours of course work must be satisfactorily completed in order to receive this degree.

BA 101 Introduction to Business.....	4
BA 104 Business Mathematics	4 OR
MTH095 Intermediate Algebra or higher	4
BA 110X Business Computer Apps/MS Excel	3
BA 131 Introduction to Business Computing	4
BA 177 Payroll Accounting	4
BA 206 Principles of Management.....	4
BA 209Q Accounting Applications/QuickBooks	3
BA 211 Principles of Accounting	4
BA 214 Business Communications.....	3 OR
WR 227 Technical Report Writing.....	3
BA226 Business Law.....	4 OR
CJ220 Criminal Law.....	3
BA 280 Cooperative Work Experience/Business.....	3
BA 284 Pre-Employment Seminar	1
BA 285 Human Relations in Business	3
BT 121 Keyboarding	3
BT 122 Keyboarding	3
BT 123 Keyboarding	3
BT 124 Applied Keyboarding.....	3
BT 131 Legal Office Procedures.....	3 OR
BT 116 Office Procedures.....	3
BT 140 Business Document Editing	3
BT 201M Word Processing /MS Word	3
BT 202M Word Processing /MS Word	3
BT 206 Desktop Publishing.....	3
BT 220 Calculating Machines.....	3
BT 225 Machine Transcription.....	2
BT 230 Legal Terminology	3
BT 231 Legal Transcription	3
CJ Elective	9
HTM 101 Customer Service.....	3
SP 111 Fundamentals of Speech.....	3
WR 121 English Composition.....	3

Note: Students enrolled in this curriculum should contact their business advisor for approved electives. Some criminal justice courses may not be offered every year. Consult your business advisor for available courses.

A.A.S./Administrative Assistant: Medical Option



Business and Management



Health Services

Intended Program Outcomes:

This two-year program leading to an A.A.S. in administrative office assistant, medical option, provides students with the specialized skills necessary for employment as medical administrative assistants. Students will be effective in the workplace in the following areas:

- Use of appropriate medical terminology with written and oral accuracy.
- Use of transcription machines effectively to produce medical documents.
- Office bookkeeping and general accounting tasks.
- Effective use of database and spreadsheet software.

Employment possibilities include hospitals, medical laboratories, and doctors' offices.

At least 96 credit hours of course work must be satisfactorily completed in order to receive this degree.

CREDITS

BA 104 Business Mathematics	4 OR
MTH095 Intermediate Algebra or higher.....	4
BA 110A Business Computer Applications/MS Access	3
BA 110X Business Computer Applications/MS Excel.....	3
BA 131 Introduction to Business Computing	4
BA 177 Payroll Accounting	4
BA 209Q Accounting Applications/	3
BA 211 Principles of Accounting	4
BA 214 Business Communications	3
BA 277 Business Ethics	3
BA 284 Pre-Employment Seminar	1
BA 285 Human Relations in Business	3
BT 116 Office Procedures.....	3
BT 121 Keyboarding.....	3
BT 122 Keyboarding	3
BT 123 Keyboarding	3
BT 124 Applied Keyboarding	3
BT 140 Business Document Editing	3
BT 201M Word Processing/ MSWord	3
BT 202M Word Processing/ MSWord.....	3
BT 206 Desktop Publishing.....	3
BT 220 Calculating Machines	3
BT 225 Machine Transcription	2
BT 251 Medical Terminology	3
BT 252 Medical Terminology	3
BT 253 Medical Transcription	3
BT 254 Medical Transcription	3
BT 257 Medical Office Procedures	3
BT 258 Medical Insurance Procedures	3
BT 280 Cooperative Work Experience	2
HTM 101 Customer Service.....	3
SP 111 Fundamentals of Speech	3
WR 121 English Composition	3

Note: Students enrolled in this curriculum should contact their business advisor for approved electives.

A.A.S./Agriculture Business



Business and Management



Agriculture, Food, and Natural Resources Systems

Intended Program Outcomes:

This two-year program leading to an A.A.S. in agriculture business will prepare the student for a career in the broad field of agri-business or in support areas of production agriculture by providing the necessary knowledge in the following areas:

- Industry-related employment skills
- Animal science (techniques, issues, technology, trends)
- Crop science (techniques, issues, technology, trends)
- Agriculture-related business practices
- Agricultural operations (safety, mechanical technology)

Opportunities are available in sales of equipment, fertilizer and chemicals, agricultural credit, record-keeping and other areas. Many of the business and agriculture courses may be transferred to other four-year colleges. Students wishing to transfer to a four-year institution should review with their advisor the transferability of their courses and should review the program requirements of that school. The following schedule is illustrative only; an individual student's schedule may be different.

At least 94 credit hours of course work must be satisfactorily completed in order to receive this degree.

CREDITS

AGM 131 Agriculture Safety	3
AGM 140 Agriculture Engines	3
AGM 211 Agriculture Construction & Surveying	3
AGM 221 Metals & Welding	3
AGR 101 Agriculture Orientation	1
AGR 111 Agriculture Computers	3
AGR 200 Pre-Employment Seminar	1
AGR 210 Agriculture Accounting	4
AGR 211 Agriculture Business Management	3
AGR 221 Agriculture Marketing	3
AGR 226 Agriculture Issues	3
AGR 280 Cooperative Work Experience	2
AGR 296 Production Problems	4
ANS 121 Animal Science	3
ANS 122 Animal Science	3
Business Electives*	21
CSS 100 Soils & Fertilizers	3
CSS 210 Forage Crops	3
EC 201 Principles of Economics/Microeconomics	3
EC 202 Principles of Economics/Macroeconomics	3
HE 252 First Aid	3 OR
HPE 295 Health & Fitness for Life	3
HORT 100 Plant Science	3
MTH 095 Intermediate Algebra (or higher)	4
SP 111 Fundamentals of Speech (or higher)	3
WR 121 English Composition	3
WR 227 Technical Report Writing	3

A.A.S./Agriculture Production



Agriculture, Food, and Natural Resources Systems

Intended Program Outcomes:

This two-year program leading to an A.A.S. degree in agriculture/production will prepare the student concerned with the raising of an agriculture crop commodity by providing the necessary knowledge in the following areas:

- Industry-related employment skills
- Animal science (techniques, issues, technology, trends)
- Crop science (techniques, issues, technology, trends)
- Agriculture-related business practices
- Agricultural operations (safety, mechanical technology)

The curriculum includes a balanced selection of courses in the areas of crops, mechanics, and business. Students wishing to specialize in a particular area should consult their advisor to develop an academic plan. The following schedule is illustrative only; an individual student's schedule may be different.

At least 100 credit hours of course work must be satisfactorily completed in order to receive this degree.

CREDITS

AGM 131 Agriculture Safety	3
AGM 140 Agriculture Engines	3
AGM 211 Agriculture Construction & Surveying	3
AGM 221 Metals and Welding	3
AGM 240 Tractors	2
AGM 241 Agriculture Machinery	3
AGR 101 Agriculture Orientation	1
AGR 111 Agriculture Computers	3
AGR 200 Pre-Employment Seminar	1
AGR 210 Agriculture Accounting	4
AGR 211 Agriculture Business Management	3
AGR 221 Agriculture Marketing	3
AGR 226 Agriculture Issues	3
AGR 280 Cooperative Work Experience	3
AGR 296 Production Problems	4
Agriculture Elective*	15
ANS 121 Animal Science	3
ANS 122 Animal Science	3
CSS 100 Soils and Fertilizers	3
CSS 201 Principles of Crop Science	3
CSS 210 Forage Crops	3
General Education Requirement*	6
HE 250 Personal Health	3 OR
HE 252 First Aid	3
HORT 100 Plant Science	3
Human Relations Requirement*	3
MTH 060 Elementary Algebra (or higher)	4
RNG 241 Range Management	3
SP 100 Human Communication (or higher)	3
WR 065 Introduction to Technical Writing (or higher)	3

Students should contact their agriculture advisor for approved electives, general education requirements, and human relations requirements.

A.A.S./Agriculture Production: Crops Option



Agriculture, Food, and Natural Resources Systems

Intended Program Outcomes:

This two-year program leading to an A.A.S. in agriculture/production: crops will prepare the student concerned with the raising of an agriculture crop commodity by providing the necessary knowledge in the following areas:

- Industry-related employment skills
- Animal science (techniques, issues, technology, trends)
- Crop science (techniques, issues, technology, trends)
- Agriculture-related business practices
- Agricultural operations (safety, mechanical technology)

The curriculum includes a balanced selection of courses in the areas of crops, mechanics, and business. Students wishing to specialize in a particular area should consult their advisor to develop an academic plan. The following schedule is illustrative only; an individual student's schedule may be different.

At least 100 credit hours of course work must be satisfactorily completed in order to receive this degree.

CREDITS

AGM 131 Agriculture Safety	3
AGM 140 Agriculture Engines	3
AGM 211 Agriculture Construction & Surveying	3
AGM 221 Metals and Welding	3
AGM 240 Tractors	2
AGM 241 Agriculture Machinery	3
AGM 250 Irrigation Systems Design	3
AGM 251 Irrigation Systems	3
AGR 101 Agriculture Orientation	1
AGR 111 Agriculture Computers	3
AGR 200 Pre-Employment Seminar	1
AGR 210 Agriculture Accounting	4
AGR 211 Agriculture Business Management	3
AGR 221 Agriculture Marketing	3
AGR 226 Agriculture Issues	3
AGR 280 Cooperative Work Experience	5
AGR 296 Production Problems	4
ANS 121 Animal Science	3
ANS 122 Animal Science	3
ANS 211 Animal Nutrition	4
ANS 217 Artificial Insemination	3
ANS 220 Beef Production	4
ANS 221 Horses and Horsemanship	3
ANS 231 Livestock Evaluation	3
ANS 232 Livestock Evaluation	3
ANS 240 Animal Health	5
CSS 100 Soils and Fertilizers	3
CSS 201 Principles of Crop Science	3
CSS 210 Forage Crops	3
CSS 240 Pest Management	4
General Education Requirement*	6
HE 252 First Aid	3
HORT 100 Plant Science	3
HORT 111 Alternative Crop Production	3
Human Relations Requirement*	3
MTH 060 Elementary Algebra (or higher).....	4
RNG 241 Range Management	3
SP 100 Human Communication (or higher).....	3
WR 065 Introduction to Technical Writing (or higher)	3

NOTE: *Students should contact their agriculture advisor for approved electives, general education requirements, and human relations requirements for all Agriculture programs.

A.A.S./Agriculture Production: Livestock Option



Agriculture, Food, and Natural Resources Systems

Intended Program Outcomes:

This two-year program leading to an A.A.S. degree in agriculture/production: livestock will prepare the student concerned with the raising of an agriculture livestock commodity by providing the necessary knowledge in the following areas:

- Industry-related employment skills
- Animal science (techniques, issues, technology, trends)
- Crop science (techniques, issues, technology, trends)
- Agriculture-related business practices
- Agricultural operations (safety, mechanical technology)

The curriculum includes a balanced selection of courses in the areas of crops, livestock, mechanics, and business. Students wishing to specialize in a particular area should consult their advisor to develop an academic plan. The following schedule is illustrative only; an individual student's schedule may be different. At least 108 credit hours of course work must be satisfactorily completed in order to receive this degree.

CREDITS

AGM 131 Agriculture Safety	3
AGM 140 Agriculture Engines	3
AGM 221 Metals and Welding	3
AGM 241 Agriculture Machinery	3
AGM 240 Tractors	2
AGR 101 Agriculture Orientation	1
AGR 111 Agriculture Computers	3
AGR 200 Pre-Employment Seminar	1
AGR 210 Agriculture Accounting	4
AGR 211 Agriculture Business Management	3
AGR 221 Agriculture Marketing	3
AGR 226 Agriculture Issues	3
AGR 280 Cooperative Work Experience	4
AGR 296 Production Problems	4
ANS 121 Animal Science	3
ANS 122 Animal Science	3
ANS 211 Animal Nutrition	4
ANS 217 Artificial Insemination	3
ANS 220 Beef Production	4
ANS 221 Horses and Horsemanship	3
ANS 231 Livestock Evaluation	3
ANS 232 Livestock Evaluation	3
ANS 240 Animal Health	5
CSS 100 Soils and Fertilizers	3
CSS 201 Principles of Crop Science	3
CSS 210 Forage Crops	3
General Education Requirement*	6
HE 250 Personal Health	3 OR
HE 252 First Aid	3
HORT 100 Plant Science	3
Human Relations Requirement*	3
MTH 060 Elementary Algebra (or higher).....	4
RNG 241 Range Management	3
SP 100 Human Communications (or higher).....	3
WR 065 Introduction to Technical Writing (or higher)	3

APPRENTICESHIP DEGREES

A.A.S./Construction Trades, General Apprenticeship



Industrial and Engineering Systems

(Limited entry Program)

Intended Program Outcomes:

- Complete a minimum of 6000-8000 hours State of Oregon-approved on-the-job training (OJT).
- Repair, install, and maintain a variety of building construction projects using trade specific tools and techniques in compliance with building codes and OSHA regulations.
- Seventy-five percent of applicants have documented trade-specific skills listed on the Construction Trades, General Apprenticeship Outcomes Assessment Tool
- Complete required related training with a grade “C” or better

6000-8000-Hr BOLI-ATD Trades: asbestos removal, carpenter, HVAC/R, interior/exterior finisher, painter, pile driver, plumber, scaffold erector, and sheet metal.

At least 93 credit hours of course work must be satisfactorily completed in order to receive this certificate.

CREDITS

Apprenticeship Courses—24 credits required

APR 110A Plumbing App. Fundamentals.....	4
APR 110B Plumbing App. Math & Basic Installations	4
APR 110C Plumbing App. Print Reading	4
APR 110D Plumbing App. Installation.....	4
APR 110E Plumbing App. Occupancy	4
APR 110F Plumbing App. Advanced Waster System	4
APR 210G Plumbing App. Residential Installation.....	4
APR 210H Plumbing App. Commercial Installation.....	4
APR 210I Plumbing App. Code	4
APR 210J Plumbing App. Industrial Installation.....	4
APR 210K Plumbing App. Basic Waster Water System	4
APR 210L Plumbing App. Code & Test Prep.....	4

General Education courses -18 credits required

WR 060 Elements of the Essay (or higher)	3
SP 100 Human Communications (or higher)	3
MTH 060 Elementary Algebra (or higher)	4
CS120 Concepts of Computing	4 OR
BA 104 Business Mathematics	4 OR
BA 105 Business Mathematics	4
BA 285 Human Relations in Business.....	3
PSY 201 General Psychology	3
Journeyman Certification.....	27

(This degree does not guarantee licensure).

A.A.S./Electrician Apprenticeship Technologies



Industrial and Engineering Systems

(Limited– Entry Program)

Intended Program Outcomes:

- Complete 6000-8000 hours State of Oregon-approved on-the-job-training. Apply theory to electrical wiring
- Repair & install electrical wire devises according to licensure regulations to meet NEC and OSC for inside electrician, limited energy technician-license A, limited manufacturing plant electrician, sign assembler/fabricator, sign maker/erector, and stationary engineer
- Seventy-five percent of applicants have documented trade-specific skills listed on the Electrician Apprenticeship Trades Outcomes Assessment Tool

- Complete all required related-training with a grade of “C” or better

6000 Hour BOLI-ATD Trades: limited energy technician-license A and sign maker/fabricator.

8000 Hour BOLI-ATD Trades: inside electrician, manufacturing plant electrician, sign assembler/fabricator, sign maker/erector and stationary engineer. At least 93 credit hours of course work must be satisfactorily completed in order to receive this certificate.

Apprenticeship Courses —24 credits required CREDITS Inside Electrician

APR 112-A Inside Electrical App. Fundamentals.....	4
APR 112-B Inside Electrical App. AC/DC Circuits	4
APR 112-C Inside Electrical App. Measurements	4
APR 112-D Inside Electrical App. Theory	4
APR 112-E Inside Electrical App. Wiring & Print Reading.....	4
APR 112-F Inside Electrical App. Installation	4
APR 212-G Inside Electrical App. Safety & Code.....	4
APR 212-H Inside Electrical App. Motors & Controls.....	4
APR 212-I Inside Electrical App. Fiber Optics	4
APR 212-J Inside Electrical App. Math/Test Equipment	4
APR 212-K Inside Electrical App. Voltage.....	4
APR 212-L Inside Electrical App. Code & Test Prep	4
OR Limited Manufacture Plant Electrician	
APR 111-A LMPE App. Fundamentals	4
APR 111-B LMPE App. AC/DC Circuits	4
APR 111-C LMPE App. Measurement.....	4
APR 111-D LMPE App. Theory.....	4
APR 111-E LMPE App. Wiring & Print Reading	4
APR 111-F LMPE App. Installation.....	4
APR 211-G LMPE App. Safety & Code	4
APR 211-H LMPE App. Motors & Controls	4
APR 211-I LMPE App. Fiber Optics.....	4
APR 211-J LMPE App. Math/Test Equipment.....	4
APR 211-K LMPE App. Voltage	4
APR 211-L LMPE App. Code & Test Prep	4

Intended Program Outcomes:

- Complete 4000 hours State of Oregon-approved on-the-job training (OJT)
- Repair or install electrical wire devices according to limited licensure regulations to meet NEC and OSC code for limited energy technician-license B, limited maintenance electrician, limited renewable energy technician, and limited residential electrician
- **4000 Hour BOLI-ATD Trades:** limited energy Technician-license B, limited maintenance electrician, limited renewable energy technician, and limited residential electrician. At least 93 credit hours of course work must be satisfactorily completed in order to receive this certificate.

OR Limited Maintenance Electrical

APR 115-A LME App. Fundamentals/Theory.....	4
APR 115-B LME App. AC/DC Circuits	4
APR 115-C LME Measurement & Blueprint Reading.....	4
APR 215-D LME App. Safety & Code.....	4
APR 215-E LME App. Motors & Control	4
APR 215-F LME App. Code & Test Prep	4
Electives	29

(Any AAS general education electives ; including up to 12 Career and Technical electives)

General Education courses -18 credits required

WR 060 Elements of the Essay (or higher)	3
SP 100 Human Communications (or higher)	3
MTH 060 Elementary Algebra (or higher)	4
CS120 Concepts of Computing	4 OR
BA 104 Business Mathematics.....	4 OR
BA 105 Business Mathematics.....	4

BA 285 Human Relations in Business	3
PSY 201 General Psychology	3
Journeyman Certification	22-27

(This 93-credit certificate does not guarantee licensure)

A.A.S./Business Administration



Business and Management

A.A.S./Industrial Mechanics and Maintenance Technology Apprenticeship



Industrial and Engineering Systems

(Limited-Entry Program)

Intended Program Outcomes:

- Complete a minimum of 4000 hours State of Oregon approved on-the job training (OJT)
- Repair, install, and maintain a variety of industrial equipment using trade specific tools and techniques in compliance with state regulations

CREDITS

APR 114A PLC App. Hardware/Number Systems.....	4
APR 114B PLC App. Programming Fundamentals.....	4
APR 114C PLC App. Timers, Counters, Controls.....	4
APR 114D PLC App. Operation.....	4
APR 114E PLC App. Troubleshooting	4
APR 214F PLC App. Practical Applications	4

General Education courses -18 credits required

WR 060 Elements of the Essay (or higher)	3
SP 100 Human Communications (or higher)	3
MTH 060 Elementary Algebra (or higher)	4
CS120 Concepts of Computing	4 OR
BA 104 Business Mathematics.....	4 OR
BA 105 Business Mathematics.....	4
BA 285 Human Relations in Business	3
PSY 201 General Psychology	3
Electives	29

(Any A.A.S. general education electives ; including up to 12 Career and Technical electives)

Journeyman Certification	27
--------------------------------	----

(This degree does not guarantee licensure)

Intended Program Outcomes:

This two-year A.A.S. degree program will prepare the student to either to transfer to an Oregon University System institutions on a course-by-course basis or be effective in the workplace in the following areas:

- Establish and promote a collaborative work environment where all voices are heard and valued as they contribute to shared goal
- Work within the ethical, legal, and regulatory parameters of the industry
- Calculate, compile, and analyze financial records to make practical business decisions
- Attract, screen, hire, train, and supervise personnel
- Select and integrate appropriate current and emerging technologies to support business functions
- Use verbal, non-verbal, and written communication skills effectively in the business context
- Interact effectively with clients and customers
- Use critical thinking skills to solve business problems
- Exhibit work behaviors that maximize opportunity for continued employment, increased responsibilities, and business success
- Assist in the design, implementation, and continuous assessment of business strategies based on consumer needs and market changes
- Lead a work unit in a direction that aligns with stated organizational vision, mission, and values

The program offers a combination of online and on-campus instruction along with cooperative work experience to give students a look at day-to-day experiences and decisions in the business world. For students also interested in an A.A.O.T. degree, see the information on general electives below. Program requirements are subject to change; please consult with an advisor.

At least 97 credit hours of course work must be satisfactorily completed in order to receive this degree.

CREDITS

BA 101 Introduction to Business	4
BA 104 Business Mathematics.....	4 OR
MTH095 Intermediate Algebra or higher.....	4
BA 105 Business Mathematics	4 OR
MTH095 Intermediate Algebra or higher.....	4
BA 110A Business Computer Applications/MS Access	3
BA 110X Business Computer Applications/MS Excel	3
BA 131 Introduction to Business Computing	4
BA 155 Introduction to Fraud	3
BA 206 Principles of Management	4
BA 210 Business Computer Applications/Adv Excel	3
BA 211 Principles of Accounting	4
BA 212 Principles of Accounting	4
BA 213 Principles of Accounting	4
BA 214 Business Communications	3
BA 215 Cost Accounting	4
BA 223 Principles of Marketing	4
BA 224 Human Resources Management	3
BA 226 Business Law	4
BA 249 Retail Selling.....	3
BA 265 Accounting Problems	4
BA 277 Business Ethics.....	3
BA 284 Pre-Employment Seminar	1
BA 285 Human Relations in Business	3
BT 121 Keyboarding	3
BT 201M Word Processing/MS Word	3
BT 220 Calculating Machines	3
HTM 101 Customer Service Management	3
HTM 126 Meeting and Convention Management	3
SP 111 Fundamentals of Speech	3
WR 121 English Composition	3

A.A.S./Civil Engineering Technology



Industrial and Engineering Systems

Intended Program Outcomes:

This two-year program will prepare the student either to transfer to a four-year degree program in Construction Management or be effective as a technician on a civil engineering team in the workplace in the following areas:

- Concrete design
- Applied structural design methods
- Applied technology (production software, CAD, GIS)
- Communication skills (writing, presentation techniques)
- Property surveying
- Professional skills (estimating, proposal development)

Students with appropriate math/science aptitude can complete the civil engineering/construction technology curriculum in two years at BMCC. Students desiring to transfer to four-year engineering programs are encouraged to complete the engineering transfer program requirements.

At least 95 credit hours of course work must be satisfactorily completed in order to receive this degree.

CREDITS

CET 111 Introduction to Engineering Technology	3
CET 112 Computer Aided Drafting	3
CET 114 Introduction to Geographic Info Systems	3
CET 145 Engineering Graphics	3
CET 152 Materials of Construction	2 OR
CET 162 Engineering Materials	3
CET 215 Contract Documents*	3
CET 222 Concrete Practices	4
CET 223 Soil Mechanics*	3
CET 231 Structures *	4
CET 235 Structures *	4
CET 242 Structures *	4
CET 251 Estimating Construction Costs*	4
CET 261 Hydraulics	4
CS 120 Concepts of Computing	4
EC 201 Principles of Economics/Micro*	3
GEOG 206 Geography of Oregon	3
GS 104 Physical Science/Physics	4 OR
PHY 201 General Physics*	5
Human Relations Requirement*	3
MTH 111 College Algebra	4
MTH 112 Elementary Functions	4
SP 100 Human Communications* (or higher)	3
SUR 161 Plane Surveying*	5
SUR 162 Surveying and Mapping	5
SUR 166 Highway Fundamentals	3
SUR 167 Surveying Seminar	3
WR 115 Introduction to College Writing* (or higher)	3
WR 227 Technical Report Writing*	3

* Items noted with an asterisk satisfy Boise State University articulation requirements.

Note: Students completing this degree program must meet the general education requirements listed for the associate of applied science degree in this catalog. Electives must be approved by a program advisor.

A.A.S./Diesel Technology



Industrial and Engineering Systems

Intended Program Outcomes:

This two-year A.A.S. degree will prepare graduates with the necessary skills and knowledge to enter the diesel technology field with the following capabilities:

- Service, diagnose and repair diesel engines
- Service and repair suspension and steering
- Service and replace brakes
- Diagnose and repair electrical/electronic systems
- Safe shop practices
- Written and oral communication skills in dealing with customer service and report writing
- Ability to use math in problem solving
- Ability to effectively use the computer to find information, create documents and send correspondence
- Understand and service basic hydraulic systems
- Ability to perform basic arc and oxy-acetylene welding

This two-year program leads to an A.A.S. Degree and is designed to prepare graduates to meet job entry requirements for a variety of jobs in the field. The curriculum provides classroom work and practical experience in the lab. In addition to heavy truck this program offers training in agricultural and heavy equipment.

At least 94 credit hours of course work must be satisfactorily completed in order to receive this degree.

CREDITS

BA284 Pre-employment Seminar	1 OR
AGR200 Pre-employment Seminar	1
BT120 Keyboarding.....	2
CS120 Concepts of Computing.....	4 OR
BA131 Intro to Business Computing.....	4
BT120 Keyboarding.....	2
DSL 141 Heavy Duty Steering & Suspension	4
DSL 151 Heavy Duty Brakes	3
DSL 152 Manual Drive Trains I	3
DSL 153 Manual Drive Trains II	3
DSL 161 Diesel Engines.....	3
DSL 162 Engine Repair I	3
DSL 175 Heavy Equipment.....	3
DSL 176 Mobile Air-conditioning & Heating	3
DSL 181 Shop Practices.....	3
DSL 184 Applied Fluid Mechanics.....	4
DSL 191 Electrical Systems I	4
DSL 192 Electrical Systems II	4
DSL 193 Electrical Systems III	4
DSL 196 Diesel Electronics (Electronic Diagnostics).....	3
DSL 241 Frames, Couplings & Trailers.....	3
DSL 251 Heavy Duty Brakes II.....	3
DSL 262 Engine Repair II	3
DSL280 Cooperative Work Experience	6
General Education Elective*	3
HD 100 College Survival & Success.....	3
HE 252 First Aid.....	3
MTH 042 Technical Mathematics	4
SP100 Human Communications (or higher).....	3
WLD 111 Basic Gas & Arc Welding.....	3
WLD 112 Advanced Arc Welding	3
WR065 Technical Report Writing (or higher).....	3

**This project was funded in part by a grant awarded under the Community Based Job Training Grants, as implemented by the U.S. Department of Labor's Employment and Training Administration; the grant requires that veterans receive preference among applicants meeting program requirements.*

A.A.S./Drafting Technology



Industrial and Engineering Systems

Intended Program Outcomes:

This two-year A.A.S. degree program in drafting technology will prepare the student to be effective as a drafting/CAD (computer-aided drafting) technician in the workplace in the following areas:

- Applied structural detailing
- Applied construction monitoring
- Applied technology (production software, CAD, geographical information systems/GIS)
- Communication skills (writing, presentation techniques)
- Property surveying
- Contract documents, estimating

Students with appropriate math and visualization skills and good attention to detail can complete the drafting technology curriculum in two years at BMCC.

At least 96 credit hours of course work must be satisfactorily completed in order to receive this degree.

CREDITS

CET 111 Introduction to Engineering Technology	3
CET 112 Computer-Aided Drafting	3
CET 113 Advanced Computer Aided Drafting	3
CET 114 Introduction to Geographic Info Systems	3
CET 145 Engineering Graphics	3
CET 152 Materials of Construction	2 OR
CET 162 Engineering Materials	3
CET 205 Structural Drafting	3
CET 215 Contract Documents	4
CET 222 Concrete Practices	4
CET 223 Soil Mechanics	3
CET 251 Estimating Construction Costs	4
CET 263 3-D Computer Aided Drafting	3
CET 280 Cooperative Work Experience	9
Computer Science Elective*	4
GEOG 101 Physical Geography	3 OR
Science Elective*	3/4
GEOG 206 Geography of Oregon	3 OR
Social Science Elective*	3/4
GS 104 Physical Science/Physics	4
Human Relations Requirement*	3
MTH 060 Elementary Algebra (or higher)	4
SP 100 Human Communications (or higher)	3
SUR 161 Plane Surveying	5
SUR 162 Surveying and Mapping	5
SUR 166 Highway Fundamentals	3
SUR 167 Surveying Seminar	3
AAOT Elective*	3
WR 060 Elements of the Essay	3
WR 065 Introduction to Technical Writing	3

* All electives should be selected with associate of arts degree requirements in mind.

A.A.S./Early Childhood Education



Human Resources

Intended Program Outcomes:

This two-year A.A.S. degree program in early childhood education (ECE) will prepare students to work with young children from birth through eight years of age and with their families in a variety of settings including child care centers, family child care settings,

preschools, Head Start programs, school age programs, and home visiting and parent education programs. This program will prepare students with the requisite knowledge and skills in the following areas:

- Organization
- Critical thinking
- Regulatory systems
- Community resources
- Special needs
- Assessment and observation
- Guidance and classroom management
- Child development
- Cultural diversity
- Environments
- Curriculum
- Developmentally appropriate practices

This degree is based on the Guidelines for Preparation of Early Childhood Professionals from the National Association for the Education of Young Children (NAEYC), which qualifies the student to become, among other professional roles, a lead teacher in a child care facility licensed by the Oregon Child Care Division, a teacher in a Head Start program, and a home visitor in the human services field. Some courses in the program may not transfer to other institutions. Students intending to transfer should select electives that meet the A.A.O.T. requirements. It is strongly recommended that students seek advisor assistance prior to and throughout their BMCC educational experience.

A minimum of 93 credits is required for this degree. The student is required to complete a criminal history check prior to enrollment in ECE 161/ECE 163: Practicum or ECE 280: Cooperative Work Experience (CWE).

Required core courses (26 credits):

	CREDITS
ECE 101 Family and Community Relations	3
ECE 150 Observation/Assessment and Recording	3
ECE 151 Guidance and Classroom Management	3
ECE 280 Cooperative Work Experience	8
ECE 226 Child Development	3
ECE 240 Curriculum/Planning	3
ECE 248 Overview of Special Services	3

ECE Electives (15 credits):

ECE 100 Developmentally Appropriate Practice in ECE	3
ECE 111 Introduction to Environments	3
ECE 152 Creativity for Young Children	3
ECE 153 Music and Movement	3
ECE 154 Literature and Literacy	3
ECE 198 Special Studies	3
ECE 227 Enhancing Social Emotional Development	3
ECE 249 Inclusion of Children with Special Needs	3
ECE 295 Child Care Administration	3
ECE 296 Issues and Trends	3
ECE 298 Special Studies: Professional Development	3
ED 258 Multicultural Education	3

General Education Requirements (22 credits):

MTH 060 Elementary Algebra (or higher)	4 OR
CS 120 Concepts of Computing	4
Health Elective	3/4
Human Relations Electives	9
SP 100 Human Communications (or higher)	3
WR 060 Elements of the Essay (or higher)	3

General Electives (34 credits)

Total Credits	93
---------------	----

A.A.S./Hospitality Management



Business and Management



Human Resources

Intended Program Outcomes:

This two-year program will prepare the student either to transfer to an Oregon University System institution on a course-by-course basis, or be effective in a career as manager in the hospitality and tourism industries by having the requisite knowledge in the following areas:

- Identify, understand, and apply market-appropriate professional guest service standards to deliver competitive guest experiences to diverse cultural groups
- Identify specific hospitality industry functions and their required procedures and legal techniques
- Identify techniques for successfully managing human resources and human relations in business
- Analyze financial statements, isolate potential problems, and identify appropriate corrective action to control and manage the critical revenue and cost centers
- Demonstrate the ability to solve mathematical problems commonly encountered in hospitality related business setting
- Utilize the technical/computer skills for keeping business records and preparing financial statements
- Develop skills for human relations activities for day-to-day business operations
- Write effective routine, routing, and persuasive styles of written communication
- Employ effective verbal communications in a variety of settings
- Develop skills for social/professional aspects of conducting business with individuals and groups
- Prepare marketing and presentation documents for marketing of business

This degree is an instructional program that prepares individuals to manage operations and facilities that provide food and/or lodging services to the traveling public or the communities around them.

Students who complete this degree may have a competitive advantage in applying for management positions. In addition, this program helps students gain the confidence and necessary business skills to develop tourism/hospitality entrepreneurship opportunities.

At least 95 credits are required to complete this degree program.

CREDITS

BA 104 Business Math.....	4 OR
MTH095 Intermediate Algebra or higher	4
BA 131 Introduction to Business Computing	4
BA 206 Principles of Management.....	4
BA 211 Principles of Accounting.....	4
BA 212 Principles of Accounting.....	4
BA 223 Principles of Marketing.....	4
BA 280 Cooperative Work Experience (Hospitality).....	3
BA 284 Pre-Employment Seminar	1
BA 285 Human Relations in Business.....	3
BT 206 Desktop Publishing	3
FN 225 Nutrition	4
GEOG 206 Geography of Oregon	3 OR
GEOG 120 World/Regional Geography	3
HTM 100 Introduction to the Hospitality Industry	3
HTM 101 Customer Service Management	3
HTM 102 Hotel Restaurant and Travel Law	3
HTM 104 Travel and Tourism Industry	3
HTM 105 Introduction to the Food/Beverage Industry.....	3
HTM 107 Food and Cost Control.....	3
HTM 109 Front Desk Operations	3
HTM 124 Catering/Banquet Operations	3

HTM 126 Meeting and Convention Management	3
HTM 127 Selling in the Hospitality Industry.....	3
HTM 130 Beverage Management.....	3
HTM 132 Menu Engineering	3
PSY 201 General Psychology	3
SOC 204 General Sociology	3
SP 111 Fundamentals of Speech.....	3
SP 115 Intercultural Communication	3
WR 121 English Composition	3
WR 227 Technical Writing.....	3

Note: Students enrolled in this curriculum should contact their business advisor for approved electives.

A.A.S./Nursing



Health Services

Intended Program Outcomes:

This two-year applied science program will prepare the student to sit for testing and licensure as a registered nurse and to be effective in the workplace in the following areas:

- Basing nursing activities on practice as dictated by the theories and concepts from nursing and the natural and behavioral sciences, thereby effectively employing assessment and intervention skills, caring and relational skills for client advocacy, and teaching skills for health promotion and restoration
- Working dependently and interdependently with qualified health professionals and members of the health team in defining, planning, implementing, and evaluating the total health plan for individuals consistent with their graduating scope of practice and skills in communication, cultural respect, management, leadership, and teaching
- Being accountable for his/her own decisions, judgments, and nursing practice by using critical thinking skills, moral and ethical responsibility, and responsibilities management skills
- Exhibiting personal and professional growth by using critical thinking and knowledge integration skills to acquire new knowledge and new experiences with the continual expansion of scientific knowledge and technology

Registered nurses (RNs) use their knowledge, skills, and problem-solving abilities to help individuals, families, and groups with health needs. RNs care for and work with people to help them become healthier or to regain health after illness or surgery. Nurses teach health practices to clients and other health care providers and frequently supervise the work of nursing assistants and practical nurses. RNs also administer medications and perform treatments for patients. Nurses work in a variety of settings, including hospitals, long-term care, schools, industry, clinics, and patients' homes.

Nursing Program Admission Requirements

Students must complete the prerequisites and general education requirements before applying for admission to the program. Please refer to the nursing department pages on our Website for current admission requirements and to access the admission application packets. Success in a nursing program requires that students be computer-literate, including the use of word-processing programs, spreadsheets, and Web searches.

This program is approved by the Oregon State Board of Nursing. The goal of the nursing department is to help students develop into competent nurses through a general education at the associate degree level in the natural and behavioral sciences. Students are provided an opportunity to learn and to practice nursing in a variety of health-care settings. Graduates of this program are eligible to take National Council Licensing Examinations (NCLEX-RN*).

Pre-Nursing Requirements (must be taken before admission to the nursing program; must be completed with a C or better grade and a GPA of 3.0 or higher)

Course	Title	Credits
BI 231	Anatomy & Physiology	4 credits
BI 232	Anatomy & Physiology	4 credits
BI 233	Anatomy & Physiology	4 credits
CH 104	Chemistry	5 credits
FN 225	Nutrition	4 credits
BI 234	Microbiology	4 credits
WR121, WR 122	English Composition	6 credits
SP 100 or 111	Speech	3 credits
MTH 095 or higher	Intermediate Algebra	4 credits
PSY 201	General Psychology	3 credits
PSY 237	Human Development	3 credits
SOC 204	Sociology	3 credits
Total Pre-Nursing Credits:		47 credits

Nursing Requirements (taken after admission to the nursing program; must be completed with a C or better grade)

Fall – First Year (PN-Practical Nurse)

Course	Title	Credits
NUR 101	Fundamentals of Nursing	9 credits
NUR 254	Physical Assessment	3 credits
		12 credits

Winter

NUR 102	Med-Surg Nursing I	9 credits
NUR 151	Nursing Skills Lab	1 credit
PHC 211	Pharmacology	2 credits
		12 credits

Spring

NUR 103	Med-Surg Nursing II	13 credits
PHC 212	Pharmacology	2 credits
		15 credits

Fall – Second Year (RN-Registered Nurse)

NUR 203	Psychiatric/Community Nursing	11 credits
NUR 161	Nursing Skills Lab	1 credit
		12 credits

Winter

NUR 202	Maternal, Neonatal & Women's Health	11 credits
NUR 171	Nursing Skills Lab	1 credit
		12 credits

Spring

NUR 201	Advanced Med-Surg Nursing	11 credits
NUR 296	RN Review	1 credit
		12 credits

Total Nursing Credits: 75 credits

Total General Education Credits: 22 credits

Total Nursing Program Credits: 97 credits

(does not include prerequisites)

* To sit for NCLEX-RN students must take RN exit exam spring term (during the third term of the RN program).

Admission criteria are subject to change from year to year. It is the responsibility of the student to be informed. The nursing program is in transition, and program admission and pre-requisites will be different after Fall 2008. You should meet with a nursing advisor if you have questions regarding proposed changes.

A.A.S./Paraeducator



Human Resources

Intended Program Outcomes:

Students who complete this degree program will be prepared to enter the K-12 school system successfully as a paraeducator and will demonstrate the following outcomes:

- Demonstrate appropriate strategies and techniques to provide instructional support to students of diverse populations, including but not limited to students with special needs, students from poverty, and English-language learner (ELL) students
- Demonstrate attitudes and behaviors that are appropriate to meeting the needs of diverse populations
- Apply best practices in classroom management to optimize the potential for student learning
- Practice ethical and legal standards of conduct
- Apply technology effectively to support teaching and learning
- Demonstrate competence in core skill area and in written and oral communication, problem-solving, critical thinking, reading, and mathematics

This curriculum is an Oregon Department of Education-approved statewide program that meets the requirements of the No Child Left Behind Federal Legislation for “Highly Qualified” status. The paraeducator degree offers coursework designed for anyone interested in teaching and learning techniques in or working as an educational assistant in the K-12 school system. The core curriculum offers instruction in: basic teaching strategies in language arts/math/science; working with diverse, special-needs populations; technology; classroom management; and practicum experience. In addition, general education courses in human relations, communication, and computation are incorporated. The curriculum is available through distance education courses as well as face-to-face courses. This degree also satisfies the program-specific course requirements for the paraeducator certificate.

Core Career and Technical Paraeducator Requirements

CREDITS

ED 100 Introduction to Education	1
ED 113 Instructional Strategies in Language Arts.....	3
ED 114 Instructional Strategies in Math/Science	3
ED 130 Classroom Management.....	3
ED 131 Instructional Strategies	3
ED 169 Overview of Student with Special Needs	3
ED 200 Foundation of Education	3
ED 229 Learning and Development.....	3
ED 235 Educational Technology.....	3
ED 254 Instructional Strategies in ELL Students	3
ED 258 Multicultural Education.....	3
ED 280 Cooperative Work Experience Practicum.....	8

General Education Requirements:

General education requirements must total 18 credits. If competency in WR 115 and MTH 60 is met with the placement test or other means, students must take other general education courses for a total of 18 credits.

WR 115 or higher.....	6
MTH 60 or higher.....	4
SP 100 or above.....	3
Humans Relation Elective	3
General education electives (may include speech, writing, math, computer science, or human relations classes).....	15

A.A.S. computer literacy requirements are met with ED 235 Educational Technology. A.A.S. human relations requirements are met with ED 258 Multicultural Education. ED 235 and 258 cannot count as general education courses.

Lower Division Collegiate Requirements:

Health and Fitness	3
Arts and Letters	6
Social Science.....	9
Science with Laboratory.....	8

Electives: Electives include any lower division credit or career and technical course that meets A.A.O.T. transfer requirements. Students should take enough electives to meet the 93 total credits required.

Other Requirements: Students must have RD 35 or higher or competence as determined by the BMCC Education Department or the placement test.

Associate of General Studies (A.G.S.) Degree

The associate of general studies (A.G.S.) degree is a non-designated degree that requires a minimum of 90 credit hours. The candidate for the A.G.S. must understand that the degree is not a transfer degree, although some or possibly all of the courses may be accepted by another institution. General education requirements are designed to meet the core competencies outlined by the Statement of Student Outcomes on page 34.

General Education Requirements	CREDITS
Writing (WR 060 or above).....	3
Speech (SP 100 or SP 111)	3
Arts and Letters (selection from page 40).....	6
Social Science (selection from page 41)	6
Mathematics (MTH 060 or above).....	4
Science/Computer Science	4
<i>Science with laboratory</i> <i>Selection from page 40 or CS 120, CS 121, or CS 122.</i>	
Career and Technical Courses	24
<i>Twelve (12) of these credits must be achieved from one concentration.</i>	
Electives (selection from courses on pages 41-42)	40
TOTAL CREDIT REQUIREMENT	90

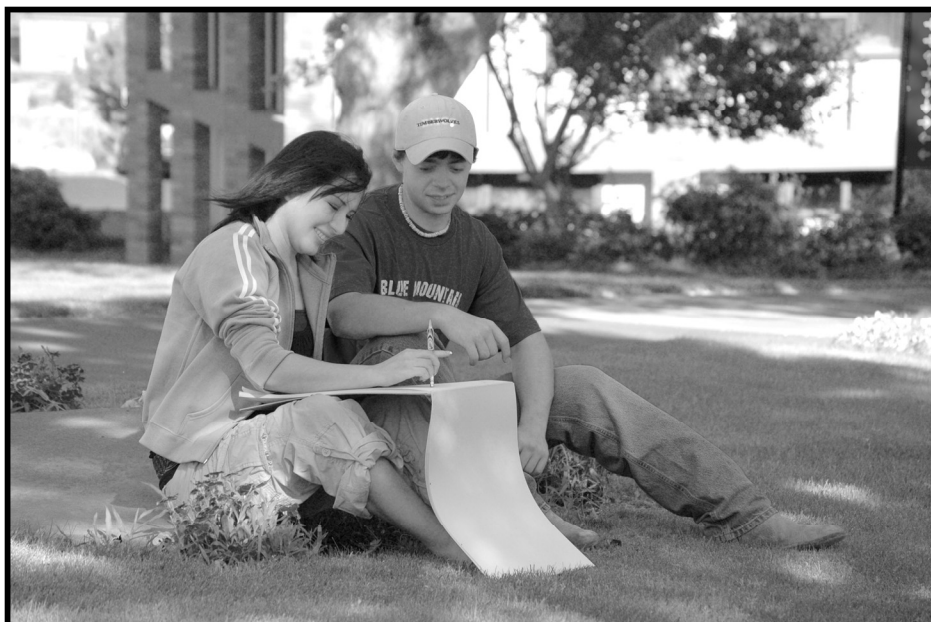

Certificates

The certificate of completion is awarded to those students who complete the requirements of a specific curriculum of less than two academic years and have a grade point average of at least 2.00 (C average).

The curriculum for a certificate of completion must include at least 9 credit hours of general education courses in the areas of communication, computation, and human relations. For specific program requirements, see the Program Description section of this catalog. Program requirements are subject to change. Please consult with an advisor for the most up-to-date information. Questions regarding suitability of any course should be directed to the Office of Enrollment Management at 541-278-5759 or by email at getinfo@bluecc.edu.

Accounting Technician Certificate



Business and Management

Intended Program Outcomes:

This one-year program leading to a certificate in accounting offers students the opportunity to develop a foundational understanding of accounting principles with an emphasis in applying that understanding to bookkeeping tasks. Learning experiences in this program are designed to assist the student in realizing the following outcomes:

- Use current computer technologies, especially spreadsheet and accounting software, to perform the duties within an accounting department
- Balance and reconcile financial information to ensure accuracy of information
- Use reconciliation processes when working with data to identify and correct errors
- Prepare professional financial statements and other reporting documents
- Model effective customer-service interactions
- Ability to effectively seek and respond to accounting-related opportunities for increased responsibilities and professional advancement
- Understand various business functions as they contribute to the success of an organization

Employment possibilities include bookkeeper, accounting clerk, and payroll clerk. Jobs are available in business, industry, government agencies, service industries, and banks.

At least 54 credit hours of course work must be satisfactorily completed in order to receive this certificate.

CREDITS

BA 101 Introduction to Business	4
BA 104 Business Mathematics.....	4 OR
MTH095 Intermediate Algebra or higher.....	4
BA 105 Business Mathematics.....	4 OR
MTH095 Intermediate Algebra or higher.....	4
BA 110X Business Computer Applications/MS Excel	3
BA 131 Introduction to Business Computing	4
BA 177 Payroll Accounting	4
BA 209Q Quick Books	3
BA 210 Business Computer Applications/Excel	3
BA 211 Principles of Accounting	4
BA 212 Principles of Accounting	4
BA 213 Principles of Accounting	4
BA 284 Pre-Employment Seminar	1
BA 285 Human Relations in Business	3
BT 220 Calculating Machines	3
SP 111 Fundamentals of Speech	3
WR 121 English Composition.....	3

APPRENTICESHIP CERTIFICATES

Construction Trades, General Apprenticeship Certificate (Plumbing)



Industrial and Engineering Systems

(Limited-Entry Program)

Intended Program Outcomes:

- Complete a minimum of 6000 to 8000 hours State of Oregon-approved on-the-job training (OJT)
- Repair, install, and maintain a variety of building construction projects using trade specific tools and techniques in compliance with building codes and OSHA regulations
- Seventy-five per cent of applicants have documented trade-specific skills listed on the Construction Trades, General Apprenticeship Outcomes Assessment Tool
- Complete required related training with a grade "C" or better

6000-8000-Hr BOLI-ATD Trades: asbestos removal, carpenter, HVAC/R, interior/exterior finisher, painter, pile driver, plumber, scaffold erector, and sheet metal.

At least 48 credit hours of course work must be satisfactorily completed in order to receive this certificate.

CREDITS

APR 110A Plumbing App. Fundamentals	4
APR 110B Plumbing App. Math & Basic Installations	4
APR 110C Plumbing App. Print Reading.....	4
APR 110D Plumbing App. Installation	4
APR 110E Plumbing App. Occupancy.....	4
APR 110F Plumbing App. Advanced Waster System	4
APR 210G Plumbing App. Residential Installation.....	4
APR 210H Plumbing App. Commercial Installation.....	4
APR 210I Plumbing App. Code	4
APR 210J Plumbing App. Industrial Installation.....	4
APR 210K Plumbing App. Basic Waster Water System .	4
APR 210L Plumbing App. Code & Test Prep.....	4

(This certificate does not guarantee licensure.)

Electrical Apprenticeship Technologies Certificate



Industrial and Engineering Systems

(Limited-Entry Program)

Intended Program Outcomes:

- Complete a minimum of 6000 to 8000 hours State of Oregon-approved on-the-job training (OJT)
- Repair, install, and maintain a variety of building construction projects using trade specific tools and techniques in compliance with building codes and OSHA regulations
- Seventy-five per cent of applicants have documented trade-specific skills listed on the Construction Trades, General Apprenticeship Outcomes Assessment Tool
- Complete required related training with a grade "C" or better

6000 Hour BOLI-ATD Trades: limited energy technician-license A and sign maker/fabricator.

8000 Hour BOLI-ATD Trades: inside electrician, manufacturing plant electrician, sign assembler/fabricator, sign maker/erector and stationary engineer.

At least 48 credit hours of course work must be satisfactorily completed in order to receive this certificate.

CREDITS

Apprenticeship Courses—48 credits required

Inside Electrician

APR 112-A Inside Electrical App. Fundamentals.....	4
APR 112-B Inside Electrical App. AC/DC Circuits	4
APR 112-C Inside Electrical App. Measurements	4
APR 112-D Inside Electrical App. Theory.....	4
APR 112-E Inside Electrical App. Wiring & Print Reading4	
APR 112-F Inside Electrical App. Installation	4
APR 212-G Inside Electrical App. Safety & Code.....	4
APR 212-H Inside Electrical App. Motors & Controls.....	4
APR 212-I Inside Electrical App. Fiber Optics	4
APR 212-J Inside Electrical App. Math/Test Equipment4	
APR 212-K Inside Electrical App. Voltage.....	4
APR 212-L Inside Electrical App. Code & Test Prep	4

OR Limited Manufacture Plant Electrician

APR 111-A LMPE App. Fundamentals	4
APR 111-B LMPE App. AC/DC Circuits	4
APR 111-C LMPE App. Measurement.....	4
APR 111-D LMPE App. Theory	4
APR 111-E LMPE App. Wiring & Print Reading	4
APR 111-F LMPE App. Installation	4
APR 211-G LMPE App. Safety & Code.....	4
APR 211-H LMPE App. Motors & Controls	4
APR 211-I LMPE App. Fiber Optics	4
APR 211-J LMPE App. Math/Test Equipment.....	4
APR 211-K LMPE App. Voltage.....	4
APR 211-L LMPE App. Code & Test Prep	4

(This certificate does not guarantee licensure.)

Limited Electrician Apprenticeship Technologies Certificate



Industrial and Engineering Systems

(Limited-Entry Program)

Intended Program Outcomes:

- Complete 4000 hours State of Oregon-approved on-the-job-training (OJT)
- Repair or install electrical wire devices according to limited licensure regulations to meet NEC and OSC code for limited energy technician– license B, limited maintenance electrician, limited renewable energy technician, and limited residential electrician

4000 Hour BOLI-ATD Trades: limited energy technician-license B, limited maintenance electrician, limited renewable energy technician, and limited residential electrician.

At least 24 credit hours of course work must be satisfactorily completed in order to receive this certificate.

APR 115-A LME App. Fundamentals/Theory.....	4
APR 115-B LME App. AC/DC Circuits.....	4
APR 115-C LME Measurement & Blueprint Reading	4
APR 215-D LME App. Safety & Code.....	4
APR 215-E LME App. Motors & Control	4
APR 215-F LME App. Code & Test Prep.....	4

(This certificate does not guarantee licensure.)

Mechanical Maintenance Apprenticeship Certificate



Industrial and Engineering Systems

(Limited-Entry Program)

Intended Program Outcomes:

- Complete a minimum of 4000 hours State of Oregon approved on-the job training (OJT)
- Repair, install, and maintain a variety of industrial equipment using trade specific tools and techniques in compliance with state regulations
- Seventy-five percent of applicants have documented trade-specific skills listed on the Industrial Mechanics and Maintenance Technology Apprenticeship Trades Outcomes Assessment Tool
- Complete required related training with a grade "C" or better

4000-Hour BOLI-ATD Trades: air frame and power plant technician, boiler operator, and programmable logic controller.

At least 24 credit hours of course work must be satisfactorily completed in order to receive this certificate.

CREDITS

Apprenticeship Courses—24 credits required

APR 114A PLC App. Hardware/Number Systems	4
APR 114B PLC App. Programming Fundamentals	4
APR 114C PLC App. Timers, Counters, Controls	4
APR 114D PLC App. Operation	4
APR 114E PLC App. Troubleshooting.....	4
APR 214F PLC App. Practical Applications.....	4

(This certificate does not guarantee licensure.)

Dental Assisting Technician Certificate



Health Services

(Limited-Entry Program)

Intended Program Outcomes:

This one-year certificate program will prepare the student to be effective in the workplace in the following areas:

- Assist dentist with patient treatment
- Radiographic proficiency (exposure, processing, mounting, and evaluation)
- Material manipulation (selection, classification, safe handling, and disposal)
- Infection control (instrument and room processing to prevent disease transmission, OSHA compliance)
- Business office procedures (computer data entry, scheduling, and records management)
- Employment readiness (professionalism, writing skills, ethics, legal and HIPAA procedures)

Students must receive a “C” grade or above in all prerequisite dental coursework to be considered as having successfully completed the program. The program is accredited by the American Dental Association’s Commission on Accreditation of Dental and Auxiliary Education Programs and by the Oregon Board of Dentistry. Graduating students are eligible to take the Dental Assisting National Board Examination.

Admission Requirements

Enrollment information is available from the Office of Enrollment Management in Morrow Hall on the BMCC Pendleton campus or online at BMCC’s Website. Completed enrollment application materials will be accepted January 1 through the last Friday in April for admission for the following fall term. (Applications will not be held over for subsequent years’ admission.) Students must have completed or be enrolled in the prerequisite courses before applying for admission to the program.

Dental Assisting Technician Curriculum

Before Fall Term Entry:

The following courses must be completed with a C grade or higher by the end of the spring term:

COURSE	CREDITS
Human Relations Elective	3
MTH 025 Pre-Algebra (or higher)	3
SP 100 Human Communications (or higher)	3
WR 060 Elements of the Essay (or higher).....	3

Students must present proof of two MMR (measles, mumps, rubella) vaccinations, a negative tuberculin skin test or chest x-ray, initiation of the Hepatitis B vaccination series, and tetanus vaccination, as well as a current Health Care Provider level “C” CPR card that expires after completion of the program.

Courses within the dental assisting curriculum can be used as the career and technical credits for the associate degree in general studies.

	CREDITS
DA 141 Dental Radiology	4
DA 142 Dental Radiology	3

DA 143 Dental Radiology	1
DA 151 Chairside Procedures	3
DA 152 Chairside Procedures	3
DA 153 Chairside Procedures.....	2
DA 154 Dental Specialties	2
DA 161 Clinical Practice.....	2
DA 162 Clinical Practice	4
DA 163 Clinical Practice	8
DA 166 Clinical Practice Seminar.....	1
DA 170 Basic Dental Science	3
DA 172 Dental Anatomy	4
DA 174 Dental Pathology	1
DA 176 Dental Pharmacology	1
DA 180 Dental Materials	3
DA 182 Dental Laboratory Materials and Procedures	2
DA 190 Dental Health Education	2
DA 192 Dental Law and Ethics	1
DA 194 Dental Business Office	3
DA 196 Medical Emergencies in the Dental Office	1

Hospitality, Tourism, and Management Certificate



Business and Management



Human Resources

Intended Program Outcomes:

This one-year program introduces students to the field of the hospitality industry, including tourism, travel, and management. Online and classroom instruction and cooperative work experience offer students a look into the day-to-day experiences at hospitality and tourism sites.

Learning experiences in this program are designed to assist the student in realizing the following outcomes:

- Identify specific hospitality industry functions and their required procedures and legal techniques
- Understand and apply market-appropriate professional guest service standards to deliver competitive guest experiences to diverse cultural groups and throughout business and industry
- Identify general business functions to maintain day-to-day operations
- Demonstrate the ability to solve mathematical problems commonly encountered in hospitality-related business setting
- Utilize the technical/computer skills for keeping business records and preparing basic financial statements
- Identify techniques for successfully managing human resources and human relations in business
- Utilize various techniques for effect verbal and written communications
- Prepare general documents related to career searches and job applications

This certificate helps prepare students for entry-level positions in management and helps students develop the professionalism necessary for business success and upward mobility in the hospitality and tourism industry.

At least 46 credit hours of course work must be satisfactorily completed in order to receive this certificate.

Employment Opportunities:

Graduates of this program may enter the hospitality industry working in such areas as hotel marketing, sales and operations, bed and breakfast operations, meeting and convention planning, special occasion planning, restaurant management, catering and banquet operations, and casino supervision.

CREDITS

BA 104 Business Math	4 OR
MTH095 Intermediate Algebra or higher	4
BA 131 Introduction to Business Computing	4
BA 223 Principles of Marketing	4
BA 280 Cooperative Work Experience.....	3
BA 285 Human Relations in Business	3
BT 121 Keyboarding	3
GAM 225 Introduction to Gaming Management	4
HTM 100 Introduction to Hospitality Industry	3
HTM 101 Customer Service Management	3
HTM 102 Hotel, Restaurant and Travel Law	3
HTM 104 Intro to Travel & Tourism.....	3
HTM 126 Meeting and Convention Management	3
SP 111 Fundamentals of Speech	3
WR 121 English Composition	3

Note: Students may need to meet prerequisites for specific classes, requiring additional coursework. Students should consult their business advisor each term for courses before registering for classes.

Office Assistant Certificate



Business and Management

Intended Program Outcomes:

This one-year certificate program is designed to provide specialized training and skills for work as an office assistant. Emphasis is placed on the study of general office skills, including practical experience on current equipment and software. The course work lays the foundation for a two-year A.A.S. degree program for those students who want to continue their education.

- Use current and emerging word-processing technologies to produce documents
- Meet or exceed the current speed and accuracy requirements for typing and 10-key operation in the industry
- Model effective customer service interactions
- Perform the general office procedures of filing, equipment operation, mail distribution, phone calls, and tasks requiring basic math calculations

At least 45 credit hours of course work must be satisfactorily completed in order to receive this certificate.

CREDITS

BA 101 Intro to Business	4
BA 104 Business Math	4 OR
MTH095 Intermediate Algebra or higher.....	4
BA 110X Business Computer Applications-Excel.....	3
BA 131 Introduction to Business Computing	4
BA 284 Pre-Employment Seminar	1
BA 285 Human Relations in Business	3
BT 116 Office Procedures	3
BT 121 Keyboarding	3
BT 122 Keyboarding	3
BT 123 Keyboarding	3
BT 140 Business Document Editing	3
BT 220 Calculating Machines	3
BT 225 Machine Transcription	2
SP 100 Human Communications	3 OR
SP 111 Fundamentals of Speech.....	3
WR 121 English Composition	3

Note: Students enrolled in this curriculum should contact their business advisor for approved electives.

Office Assistant: Medical Option Certificate



Business and Management



Health Services

Intended Program Outcomes:

This one-year certificate program is designed to provide specialized training and skills for entry-level positions as receptionists and/or records clerks in medical offices. Emphasis is placed on the study of general office skills as well as medical office theories and policies, including practical experience on current equipment and software. The course work lays the foundation for a two-year A.A.S. degree program for those students who want to continue their education.

- Use current and emerging work processing technologies to produce documents
- Meet or exceed the current speed and accuracy requirements for typing and 10-key operation in the industry
- Model effective customer service interactions
- Perform the general office procedures of filing, equipment operation, mail distribution, phone calls, and tasks requiring basic math calculations
- Use appropriate medical terminology with written and oral accuracy

At least 47 credit hours of course work must be satisfactorily completed in order to receive this certificate.

CREDITS

BA 104 Business Math	4 OR
MTH 095 Intermediate Algebra or higher	4
BA 110X Business Computer Applications- Excel	3
BA 131 Introduction to Business Computing	4
BA 284 Pre-Employment Seminar	1
BA 285 Human Relations in Business.....	3
BT 116 Office Procedures	3
BT 121 Keyboarding	3
BT 122 Keyboarding	3
BT 123 Keyboarding	3
BT 140 Business Document Editing	3
BT 220 Calculating Machines	3
BT 225 Machine Transcription.....	2
BT 251 Medical Terminology	3
BT 252 Medical Terminology	3
BT 257 Medical Office Procedures	3
WR 121 English Composition.....	3

Note: Students enrolled in this curriculum should contact their business advisor for approved electives.

Paraeducator Certificate



Human Resources

Intended Program Outcomes:

Students who complete this one-year certificate program will be prepared to enter the K-12 school system successfully as paraeducators and will demonstrate the following outcomes:

- Demonstrate appropriate strategies and techniques to provide instructional support to students of diverse populations, including but not limited to students with special needs, students from poverty, and English-language learner (ELL) students
- Demonstrate attitudes and behaviors that are appropriate to meeting the needs of diverse populations
- Apply best practices in classroom management to optimize the potential for student learning
- Practice ethical and legal standards of conduct
- Apply technology effectively to support teaching and learning
- Demonstrate competence in the core skill area and in written and oral communication, problem-solving, critical thinking, reading, and mathematics

This curriculum is an Oregon Department of Education-approved statewide program that meets the requirements of the No Child Left Behind Federal Legislation for "Highly Qualified" status. The core curriculum offers instruction in; basic teaching strategies in language arts/math/science, working with diverse, special-needs populations, technology, classroom management; and practicum experience. In addition, general education courses in human relations, communication, and computation are incorporated. The curriculum is available through distance education courses as well as face-to-face courses. The paraeducator certificate also satisfies some of the program-specific course requirements for the paraeducator A.A.S. degree.

CREDITS

ED 100 Introduction to Education.....	1
ED 113 Instructional Strategies in Lang. Arts.....	3
ED 114 Instructional Strategies in Math/Science.....	3
ED 130 Classroom Management	3
ED 131 Instructional Strategies	3
ED 169 Overview of Student w/ Special Needs.....	3
ED 200 Foundation of Education.....	3
ED 229 Learning and Development.....	3
ED 235 Educational Technology	3
ED 254 Instructional Strategies for ELL Students.....	3
ED 258 Multicultural Education	3
ED 280 Cooperative Work Experience Practicum	3

General education requirements must total 9 credits. If competency in WR 115 and MTH 60 is met with the placement test or other means, students must take other general education courses to total 9 total credits.

WR 115 or higher	3
MTH 60 or higher	4
General education elective (may include speech, writing, math, computer science, or human relations classes).....	3

The computer literacy requirement may be met with the ED 235 Educational Technology. Human relations requirements are met with ED 258 Multicultural Education. ED 235 and 258 cannot count as general education courses.

Other Requirements: Students must have RD 35 or higher or competence as determined by the BMCC Education Department or the placement test.

Total credits needed for the certificate are 50.

Practical Nursing (PN) Certificate



Health Services

Intended Program Outcomes:

This one-year certificate program will prepare the student to sit for testing and licensure as a licensed practical nurse, and to be effective in the workplace in the following areas:

- Basing nursing activities on practice as dictated by the theories and concepts from nursing and the natural and behavioral sciences, thereby effectively employing assessment and intervention skills and caring and relational skills for client advocacy
- Working dependently and interdependently with qualified health professionals and members of the health team in defining, planning, implementing, and evaluating the total health plan for individuals consistent with their graduating scope of practice, employing skills in communication and cultural respect
- Being accountable for his/her own decisions, judgments, and nursing practice through the use of critical thinking skills and moral and ethical responsibility
- Exhibiting personal and professional growth by using critical thinking and knowledge integration skills to acquire new knowledge and new experiences with the continual expansion of scientific knowledge and technology

Licensed practical nurses (LPNs) care for patients under the direction of a registered nurse (RN), physician or dentist. LPNs collect information about the patient's health, contribute to the plan of care, and administer medications and other treatments. Practical nurses work primarily in hospitals and long-term care facilities. They may also work in medical or dental offices, in clinics, and for stable patients in the community under supervision of an RN.

Practical Nursing Program Admission Requirements

Students must complete prerequisites and general education requirements before applying for admission to the program. Please refer to the nursing department pages on our Website for current admission requirements and to access the admission application packet. Success in a nursing program requires that students be computer-literate, including the use of word-processing programs, spreadsheets, and Web searches.

The practical nursing program is approved by the Oregon State Board of Nursing. The goal of the nursing department is to help students develop into competent nurses through a general education including courses at the practical-nursing level and in the natural and behavioral sciences. Students are provided an opportunity to learn and to practice nursing in a variety of health care settings. Graduates of this certificate program are eligible to take National Council Licensing Examinations (NCLEX-PN*).

Pre-Nursing Requirements (must be taken before admission to the nursing program; must be completed with a B or better grade and a GPA of 3.0 or higher)

CREDITS

Prerequisites

BI 231 Anatomy & Physiology	4
BI 232 Anatomy & Physiology	4
BI 233 Anatomy & Physiology	4
BI 234 Microbiology	4
CH 104 Chemistry	5
FN 225 Nutrition	4
Total Prerequisites	25

General Education Requirements

MTH 095 Intermediate Algebra	4
PSY 201 General Psychology	3
PSY 237 Human Development.....	3
SOC 204 Sociology	3
SP 100 Speech or higher	3
WR121, WR 122 English Composition	6
Total	22

Nursing Requirements (taken after admission to the nursing program; must be completed with a C or better grade.)

Fall – First Year (PN- Practical Nurse)

NUR 101 Fundamentals of Nursing.....	9
NUR 254 Physical Assessment.....	3
Total Fall.....	12

Winter

NUR 102 Med-Surg Nursing I	9
NUR 151 Nursing Skills Lab	1
PHC 211 Pharmacology	2
Total Winter	12

Spring

NUR 103 Med-Surg Nursing II	13
PHC 212 Pharmacology	2
Total Spring.....	15

Total General Education Credits..... 22

Total Nursing Credits: 39

Total PN Nursing Program Credits: 61

* To sit for NCLEX-PN, students must take PN exit exam (4-5 hours) and the 12 hour PN review class spring term, the third term of the PN.

Retail Management Certificate



Business and Management



Human Resources

Intended Program Outcomes:

In this one-year certificate program are designed to assist the student in realizing the following outcomes:

- Define the different types of retail outlets and related principles for successful businesses
- Illustrate unique, competitive marketing strategies for retailers including advertising, public relations, and sales promotion packages
- Demonstrate the ability to use the computer and information services for business-related activities
- Understand the principles and methods for human resource/human relations management
- Demonstrate the ability to solve mathematical problems commonly encountered in hospitality-related business settings
- Utilize the technical skills for keeping business records and preparing financial statements
- Write effective routine, routing, and persuasive styles of written communication
- Employ successful verbal communication in a variety of settings

Employment Opportunities

This certificate program focuses on developing core skills needed for entry-level sales or management positions in the retail industry.

At least 45 credit hours of coursework are required to complete this program.

	CREDITS
BA 104 Business Mathematics.....	4 OR
MTH095 Intermediate Algebra or higher	4
BA 131 Introduction to Business Computing	4
BA 206 Principles of Marketing.....	4
BA 211 Principles of Accounting.....	4
BA 214 Business Communications.....	3
BA 223 Principles of Marketing	4
BA 224 Human Resource Management.....	3
BA 249 Retail Selling	3
BA 285 Human Relations in Business	3
Retail Management Electives.....	7
SP 111 Fundamentals of Speech.....	3
WR121 English Composition.....	3

Note: Students may need to meet prerequisites for specific classes, requiring additional coursework. Students should contact their business advisor each term for approved electives before registering for classes.

Western Alliance of Food Chains (WAFC) Retail Management Certificate (less than one year)



Business and Management



Human Resources

Intended Program Outcomes:

Learning experiences in this program are designed to assist the student in realizing the following outcomes:

- Define the different types of retail outlets and related principles for successful businesses
- Illustrate unique, competitive marketing strategies for retailers including advertising, public relations, and sales promotion packages

- Demonstrate the ability to use the computer and information services for business-related activities
- Understand the principles and methods for human resource/human relations management
- Demonstrate the ability to solve mathematical problems commonly encountered in hospitality-related business settings
- Utilize the technical skills for keeping business records and preparing financial statements
- Write effective routine, routing, and persuasive styles of written communication
- Employ successful verbal communication in a variety of settings

This less-than-one-year certificate program is for current retail employees and for students who would like to become retail employees. This program is recognized by WAFC retail employers and identifies skills that lead to professional growth, hiring, and advancement opportunities. The program prepares the student for retail sales and management responsibilities; those who complete the program may be given preference in hiring, may be eligible for promotions, and may receive compensation to recognize their educational achievement.

At least 35 credit hours of coursework are required to complete this program.

	CREDITS
BA 104 Business Mathematics.....	4 OR
MTH095 Intermediate Algebra or higher	4
BA 131 Introduction to Business Computing	4
BA 206 Principles of Management	4
BA 211 Principles of Accounting	4
BA 214 Business Communications.....	3
BA 223 Principles of Marketing	4
BA 224 Human Resource Management.....	3
BA 249 Retail Selling	3
BA 285 Human Relations in Business	3
SP 111 Fundamentals of Speech	3

Note: Students enrolled in this curriculum should contact their business advisor for approved electives. This program is not currently eligible for federal financial assistance.

Welding Certificate (less than one year)



Industrial and Engineering Systems

This 12-credit-hour certificate of completion program is designed to prepare students for entry-level jobs in welding and related trades and to prepare students to pursue a certificate of completion or A.A.S. degree in welding technology from another community college. The program consists of the following courses:

	CREDITS
WLD 112 Advanced Arc Welding	3
WLD 253 Welding Practices for Certification.....	3
AGM 221 Metals and Welding.....	3 OR
WLD 111 Basic Gas and Arc Welding	3
WLD 256 Pipe Welding for Certification.....	3 OR
WLD 221 TIG Welding.....	3

This is not an industrial certification.

NOTE: This project was funded in part by a grant awarded under the Community Based Job Training Grants, as implemented by the U.S. Department of Labor's Employment and Training Administration; the grant requires that veterans receive preference among applicants meeting program requirements.

NOTE: This program is not currently eligible for federal title IV financial assistance.

Course Descriptions

Courses offered at BMCC are listed in this section of the catalog. Not every course is offered every term. Use the schedule of classes to determine quarterly course offerings. Students who plan to transfer should consult with their program advisor to ensure course transferability.

HOW TO READ A COURSE DESCRIPTION

COURSE LISTING

EXPLANATION

AGM 131 AGRICULTURE SAFETY Courses are grouped by area of study and listed alphabetically by **letter prefix** and **course number**. Courses numbered 100 and above are designed for transfer to other colleges for degree credit.
Credits - 3 Lecture - 2 Lab - 1
A basic course in agricultural safety covering hand and power tools, equipment, chemical and environmental safety. Students will develop safe working habits and identify and correct safety hazards.

AGRICULTURE SAFETY The **title of the course** is listed in all capital letters.

A basic course in agricultural safety The **course description** briefly summarizes the course content.
Covering hand and power tools

Credits - 3 Lecture - 2 Lab - 1 The **number of credits** earned by taking the course is noted. Each lecture credit corresponds to one hour of instruction per week. Each lab credit equals 3 hours per week. Each other credit generally refers to 2 hours of class time per credit.

Prerequisite or **Prerequisites** are listed below course descriptions. A prerequisite is a course that must be completed before enrolling in the selected course. It is important to note prerequisites before registering.

Corequisite **Corequisite** is a course that should be completed either before or while attending the selected course.

Explanation of Course Designations:

Symbols designate how courses fulfill various degrees as defined below.

(^) – A transferable course that can be used to fulfill undesignated **elective** requirements in the associate degree programs.

(*) – A transferable course that meets **distribution** (group) requirements in the:

Associate of arts Oregon transfer (A.A.O.T.) degree

Associate of science (A.S.) degree

Note: Courses meeting distribution requirements may always be used as electives in the transfer degrees.

(+) – Courses that meet the **laboratory** requirement.

(>) – A maximum of **12 credits** of college-level career and technical courses may be used as **electives** in the A.A.O.T. and the A.A.S. degrees.

Questions regarding suitability of courses should be directed to the program advisor, Associate Vice President of Enrollment Management, or Vice President of Instruction.

Non-Designated Courses

Courses numbered 100 and above listed in this section of the catalog that have not received a designation mark as outlined above may or may not meet degree requirements or be transferable to other institutions. Questions regarding transferability of courses should be directed to the program advisor, Associate Vice President of Enrollment Management, or Vice President of Instruction.

Non-Transfer Courses

Courses with numerical designations less than 100 are not transferable to four-year institutions.

Course Descriptions

>AGM131 - Agriculture Safety

Credits -3 Lecture - 2 Lab -1

A basic course in agricultural safety covering hand and power tools, equipment, chemical and environmental safety. Students will develop safe working habits and identify and correct safety hazards.

>AGM140 - Agriculture Engines

Credits -3 Lecture - 2 Lab -1

Students develop a practical understanding of the functioning, operation, and maintenance of the internal combustion engine particularly as it is used in agricultural operations.

>AGM211 - Agriculture Construction and Surveying

Credits -3 Lecture - 2 Lab -1

Surveying, leveling and construction in agricultural applications. No Prerequisite.

>AGM221 - Metals and Welding

Credits -3 Lecture - 2 Lab -1

A basic course in welding using oxyacetylene torches and electric arc welding equipment emphasizing the development of skills and knowledge to safely and effectively accomplish practical repairs and fabrication in agricultural applications.

>AGM240 - Tractors

Credits -2 Lecture - 1 Lab -1

This course will acquaint students with agricultural tractors and their systems. Labs will be used extensively to develop student skills in operation and maintenance of tractors. Maneuvering, attaching, detaching, and using implements will be stressed.

>AGM241 - Agriculture Machinery

Credits -3 Lecture - 2 Lab -1

Tillage, planting, and harvest equipment used in Eastern Oregon agriculture covering economic factors, operation principles, adjustments, and maintenance of commonly used machines.

>AGM249 - Advanced Agricultural Shop

Credits -2 Other - 2

Designed to build student skills in metalworking, woodworking, and agricultural mechanics with a laboratory element to allow time for in-depth practice as well as provide time for individual projects.

>AGM250 - Irrigation Systems Design

Credits -3 Lecture - 2 Lab -1

Designing drip, low pressure, and sprinkler irrigation systems with an emphasis on horticultural and field crop applications from pump to output nozzle.

>AGM251 - Irrigation Systems

Credits - 3 Lecture - 2 Lab - 1

Application of design skills learned in Irrigation Systems Design to actual in-field situations. Field trips will explore different applications of irrigation. Contemporary water issues will be discussed.

Recommended preparation: AGM250

>AGR101 - Agriculture Orientation

Credits - 1 Lecture - 1

The study of social, educational, and economic opportunities that are available on campus, in the community and in the agricultural industry. The student will plan his/her educational future and learn of different employment areas available upon graduation.

>AGR111 - Agriculture Computers

Credits - 3 Lecture - 2 Lab - 1

Application of personal microcomputers to farm and ranch situations. Use and evaluation of spread sheets, data bases, and word processing software are covered.

>AGR200 - Pre-Employment Seminar

Credits - 1 Lecture - 1

A class designed to assist the student in securing employment. Job-hunting techniques, interviewing skills, and the study of job related responsibilities and problems while advancing in a chosen career are major topics covered. A seminar format is used to encourage student participation.
Instructor approval required.

>AGR210 - Agriculture Accounting

Credits - 4 Lecture - 4

Simulation of ranch and farm record keeping including maintaining payroll, depreciation, cash flow and inventory records. Computer spreadsheets are used to assist in analysis of various farm/ranch enterprises.

>AGR211 - Agriculture Business Management

Credits - 3 Lecture - 2 Lab - 1

The study of the four basic assets needed to begin any farm or ranch business. Land, labor, capital, and management are evaluated to ascertain each component's ability to produce maximum economic returns.

>AGR221 - Agriculture Marketing

Credits - 3 Lecture - 3

The complex agriculture marketing process including study of the marketing system, marketing a specific farm commodity, and the importance of organization in marketing agricultural products.

>AGR226 - Agriculture Issues

Credits - 3 Lecture -2 Lab -1

Students will study current topics causing change in the agricultural industry. Students may research and report on trends as diverse as animal rights, chemicals and foods, land use, water rights, government subsidies, and others.

>AGR280 - Cooperative Work Experience

Credits - 1-8

Offered to agriculture students to work on-the-job in various agricultural fields to gain elective credits from BMCC. Also required in conjunction with several courses in our program.
Instructor approval required.

>AGR296 - Production Problems

Credits - 4 Lecture -4

Students will select an area related to agriculture and do a feasibility study or an economic analysis. Currently published figures will be used. The report will contain all information needed to make a justifiable and cost beneficial decision.
Instructor approval required.

ANS031 - Basics of Horse Trimming and Shoeing

Credits - 1 Lab - 1

A course emphasizing horse hoof trimming, hoof care and basic shoeing. The course will be taught with hands-on experience for private horse owners and horse enthusiasts.

>ANS121 - Animal Science

Credits - 3 Lecture -2 Lab -1

Designed to familiarize students with the various phases of animal science and the modern livestock industry. Major subject areas discussed are: the livestock industry, livestock breeds, animal products, grading, and nutrition fundamentals. Labs involve students in hands-on experience and field trips.

>ANS122 - Animal Science

Credits - 3 Lecture -2 Lab -1

Approved practices in the modern livestock industry. Students gain technical knowledge in livestock reproduction, genetics, and modern breeds. Emphasis is placed upon performing skills commonly used by successful ranchers. Completion of ANS 121 preferred but not required.

>ANS198 - Special Studies

Credits - 1-3

Designed to provide interested and capable students with the opportunity to study special topics in the animal sciences.

>ANS201 - Introduction to Equine Science

Credits -3 Lecture - 2 Lab -1

This course is an introductory course in equine science. The course emphasizes the effects of natural selection on natural and domesticated horses, selection of horses by breed and evaluation of conformation, tack selection and care, nutrition and feed rations, basic handling of horses from the ground, and general health care. Labs will parallel topics in lecture and provide students with practical applications of techniques discussed.

>ANS211 - Animal Nutrition

Credits -4 Lecture - 3 Lab -1

Designed to develop an understanding of applied animal nutrition. This course will cover proteins, carbohydrates, lipids, vitamins, minerals, and the use of these nutrients by livestock. Rations will be balanced during the laboratory sessions. AGR 280 Cooperative Work Experience is required when enrolling in ANS 211.
Recommended preparation: ANS121
Corequisite: AGR280

>ANS212 - Animal Nutrition Recitation

Credits -1 Lecture - 1

This class functions as a help session and a supplement for ANS 211 to enable students to become more proficient in balancing livestock rations. While many students can balance rations quickly and efficiently from the knowledge and skills gained in lecture and labs, others need additional instruction.
Corequisite: ANS211

Symbols: ^ - Elective	+ - Lab Science
* - Group Distribution	> - C/T Elective

Course Descriptions

>ANS216 - Pregnancy Testing/Bovine

Credits - 1 Lab - 1

This course is a "hands-in" course requiring students to pregnancy check a minimum of fifty cows to become proficient. This class has an open lab to accommodate students and give all adequate time to develop a high level of proficiency.

Recommended preparation: ANS121, ANS122 and instructor approval.

>ANS217 - Artificial Insemination

Credits -3 Lecture - 2 Lab -1

Basic considerations of reproductive physiology and artificial insemination of livestock. Emphasis in the lab is placed on the application of lecture material and developing proficiency in the artificial insemination of cattle.

Recommended preparation: ANS121 and ANS122

>ANS218 - Advanced Artificial Insemination

Credits - 1 Lab - 1

A course where students act as teaching assistants in the class to assure that this "hands-in" activity proceeds properly and safely. A.I. is a technical, difficult task requiring a great deal of practice and supervision to be done properly.
Prerequisite: ANS217

>ANS220 - Beef Production

Credits - 4 Lecture - 3 Lab - 1

Designed to enable students to learn proven practices in modern beef production. Students will develop skills which can lead to a successful cattle operation. Offered in even numbered years.

Completion of ANS121 and ANS122 recommended but not required.

>ANS221 - Horses and Horsemanship

Credits - 3 Lecture - 3 Lab - 1

Horse training, behavior, reproduction, nutrition, and diseases. The laboratory portion of the class will involve students in basic horsemanship techniques for breaking, training, evaluating, and caring properly for horses.

>ANS222 - Sheep and Swine Production

Credits - 4 Lecture - 3 Lab - 1

Fundamentals of modern sheep and swine production. Students develop skills and learn up to-date, practical information. Offered in odd numbered years.

Completion of ANS121 and ANS122 recommended but not required.

>ANS231 - Livestock Evaluation

Credits - 3 Lecture - 2 Lab - 1

The subject of livestock judging and evaluation is presented in a practical and direct manner.

Classroom study of current type and market demand is combined with actual livestock judging experience. Classes of cattle, sheep, swine, and horses will be judged.

Instructor approval required.

>ANS232 - Livestock Evaluation

Credits - 3 Lecture - 2 Lab - 1

More fully develops the principles emphasized in the first quarter. More time is spent in actual judging.

Oral reasons for many of the classes are required. Students from this class participate on our intercollegiate livestock judging team.

Recommended preparation: AGM231 or instructor approval.

>ANS233 - Livestock Evaluation/Oral Reasons

Credits - 1 Lab - 1

Oral reasons are given by Livestock Evaluation students to enhance their public speaking ability and to clearly define and justify their placements. This skill is critical to members of the Livestock Judging Team at BMCC. This training is recommended for other students who wish to improve their communication skills.

Completion of or concurrent enrollment in ANS 231 required.

>ANS240 - Animal Health

Credits - 5 Lecture - 4 Other - 1

Disease control as it relates to today's modern livestock operation, including detailed study of health problems in beef cattle and study of horse, sheep and swine diseases. The lab develops student competency in practical and useful animal health skills.

Instructor approval required.

*ANTH101 - Introduction to Physical Anthropology

Credits - 3 Lecture -3

Principles of evolution applied to evidence for human physical change and development; study of fossil humans and human variation. Satisfies science group requirements at some four-year colleges.

Recommended preparation: WR060

*ANTH102 - Introduction to Archaeology and Prehistory

Credits - 3 Lecture -3

Study of archaeological methods and evidence for the evolution of human cultures and an understanding of how and why cultures change.

Recommended preparation: CS080, WR060

*ANTH103 - Introduction to Cultural Anthropology

Credits - 3 Lecture -3

Study of the organization and functioning of selected world cultures, both Western and non-Western groups.

Recommended preparation: WR060

^ANTH298 - Special Studies

Credits - 1-3

Special topics in anthropology.

Recommended preparation: WR060

>APR110A - Plumbing Apprenticeship Fundamentals

Credits - 4 Lecture -4

This course will familiarize the apprentice with a brief history of plumbing laws governing the plumbing trade; materials and methods for installation and maintenance of potable water systems, waste and sewage disposal; the definitions, fundamentals rules, purpose and scope of the Uniform Plumbing Code (UPC).

>APR110B - Plumbing Apprenticeship Math and Basic Installation

Credits - 4 Lecture -4

This course covers the practical application of basic math to plumbing calculations and familiarize the apprentice with basic installation practices utilizing the fundamental rules of the Uniform Plumbing Code and on-the-job Occupational Health and Safety requirements.

>APR110C - Plumbing Apprenticeship Print Reading

Credits -4 Lecture - 4

This course covers installation practices for potable water, piping materials and methods for installation and maintenance of potable water systems, waste and sewage disposal, the definitions, fundamental rules, purpose and scope of the Uniform Plumbing Code (UPC).

>APR110D - Plumbing Apprenticeship Basic Installation

Credits -4 Lecture - 4

This course the apprentice will become familiar with the proper techniques for installing sanitary drainage systems, gas and electric tank type water heaters and tankless water heaters, Uniform Plumbing Code and Occupational Safety and Health Association (OSHA) requirements.

>APR110E - Plumbing Apprenticeship Occupancy

Credits -4 Lecture - 4

In this course, the plumbing apprentice will become familiar with advanced levels of blueprint reading and specialty drawings; installation of sewage and drainage systems and further study of installation and safety practices.

>APR110F - Plumbing Apprenticeship Advanced Waste System

Credits -4 Lecture - 4

This course will introduce the apprentice to several aspects of the plumbing trade, including the range of materials approved for venting purposes, the raising or lifting of waste materials to the elevation of the building drain by means of sump pumps, sewage pumps and sewage ejectors; the use of traps to prevent dangerous gases from escaping into building; and further study of installation and safety practices. Chapters 9 & 10 of the UPC.

>APR111A - LMPE Apprenticeship Fundamentals

Credits -4 Lecture - 4

Related training for the LMPE Electrical Apprentice. Subject area will enable the apprentice to receive the technical knowledge of the skills required of an LMPE Electrician. Context will include trade history and concepts, trade math, basic electrical DC theory, and introduction to National Electrical Code.

>APR111B - LMPE Apprenticeship AC/DC Circuits

Credits -4 Lecture - 4

Related training for LMPE Electrical Apprentice. The student will receive the technical knowledge of the skills required of an LMPE Electrician. Content will cover mathematical formulas of equations, basic AC theory, use of test equipment and applicable National Electrical Code.

>APR111C - LMPE Apprenticeship Measurement

Credits - 4 Lecture - 4

This course is designed to familiarize the LMPE Electrical apprentice with advanced aspects of electrical theory, math and power distribution along with practical residential wiring and the National Electrical Code.

**Symbols: ^ - Elective + - Lab Science
* - Group Distribution > - C/T Elective**

Course Descriptions

>APR111D - LMPE Apprenticeship Theory

Credits - 4 Lecture - 4

This course covers related training for the LMPE Electrical Apprentice. The student will receive the technical knowledge of the skills required of an LMPE Electrician. Course content includes the requirements for wiring and installation of electrical devices, transformers, over-current devices, wire devices, hazardous locations, residential calculation and application of the National Electrical Code.

>APR111E - LMPE Apprenticeship Wiring and Print Reading

Credits - 4 Lecture - 4

This course covers related training for LMPE Apprentice. The apprentice will receive the technical knowledge of the skills required of an LMPE Electrician. The content will include requirements for wiring and installation of electrical devices, auxiliary gutters, raceways, fuses and over-current devices, wire devices, hazardous locations, busways, residential calculation and applicable national electrical code.

>APR111F - LMPE Apprenticeship Installation

Credits - 4 Lecture - 4

This course covers the requirements for wiring and installation of electrical devices, auxiliary gutters, raceways, fuses and over-current devices, hazardous locations, busways, residential calculation and applicable National Electrical Code for LMPE electrician apprentices.

>APR112A - Inside Electrical Apprenticeship Fundamentals

Credits - 4 Lecture - 4

Related training for Inside Wire Electrician Apprentice. Subject area will enable the apprentice to receive the technical knowledge of the skills required of an Inside Wire Electrician. Context will include trade history and concepts, trade math, basic electrical DC theory, and introduction to National Electrical Code.

>APR112B - Inside Electrician Apprenticeship AC/DC Circuits

Credits - 4 Lecture - 4

Related training for Inside Wire Electrician Apprentice. The student will receive the technical knowledge of the skills required of an Inside Wire Electrician. Content will cover mathematical formulas of equations, basic AC theory, use of test equipment and applicable National Electrical Code.

>APR112C - Inside Electrical Apprenticeship Measurement

Credits - 4 Lecture - 4

This course is designed to familiarize the Inside Electrical apprentice with advanced aspects of electrical theory, math and power distribution along with practical residential wiring and the National Electrical Code.

>APR112D - Inside Electrical Apprenticeship Theory

Credits - 4 Lecture - 4

This course covers related training for the Inside Wire Electrical Apprentice. The student will receive the technical knowledge of the skills required of an Inside Wire Electrician. Course content includes the requirements for wiring and installation of electrical devices, transformers, over-current devices, wire devices, hazardous locations, residential calculation and application of the National Electrical Code.

>APR112E - Inside Electrical Apprenticeship Wiring and Print Reading

Credits - 4 Lecture - 4

This course covers related training for Inside Wire Electrical Apprentice. The apprentice will receive the technical knowledge of the skills required of an Inside Wire Electrician. The content will include requirements for wiring and installation of electrical devices, auxiliary gutters, raceways, fuses and over-current devices, wire devices, hazardous locations, busways, residential calculation and applicable national electrical code.

>APR112F - Inside Electrician Apprenticeship Installation

Credits - 4 Lecture - 4

This course covers the requirements for wiring and installation of electrical devices, auxiliary gutters, raceways, fuses and over-current devices, hazardous locations, busways, residential calculation and applicable National Electrical Code for Inside Wire Electrician apprentices.

>APR114A - PLC Apprenticeship Hardware/ Number Systems

Credits - 4 Lecture - 4

This course covers related training for the Programmable Logic Controller (PLC) apprentice to study theory and trade practices. Content includes an introduction to the trade, application, scope requirements, design, development, documentation, troubleshooting, programming, analog interface, and Input/Output concepts needed for understanding PLC's in the workplace.

>APR114B - PLC Apprenticeship Programming Fundamentals

Credits - 4 Lecture - 4

This course covers related training for Programmable Logic Controller (PLC) apprentices to study theory and trade practices with content focused on input and output modules, creating a modular PLC, processors, introduction to ControlNet/DeviceNet, data organization, and basic relay instructions.

>APR114C - PLC Apprenticeship Timers, Counters, Controls

Credits - 4 Lecture - 4

This course covers related training for Programmable Logic Controller (PLC) apprentices to study theory and trade practices, the course includes relay instructions, programmable controller input modules, system documenting, timer and counter instructions, comparison, data-handling, sequencer, and program flow instructions.

>APR115A - LME Apprenticeship Fundamentals

Credits - 4 Lecture - 4

Related training for the LME Electrical Apprentice. Subject area will enable the apprentice to receive the technical knowledge of the skills required of an LME Electrician. Context will include trade history and concepts, trade math, basic electrical DC theory, and introduction to National Electrical Code.

>APR115B - LME Apprenticeship AC/DC Circuits

Credits - 4 Lecture - 4

Related training for LME Electrical Apprentice. The student will receive the technical knowledge of the skills required of an LME Electrician. Content will cover mathematical formulas of equations, basic AC theory, use of test equipment and applicable National Electrical Code.

>APR115C - LME Apprenticeship Blueprint Reading

Credits - 4 Lecture - 4

This course covers related training for LME Apprentice. The apprentice will receive the technical knowledge of the skills required of an LME Electrician. The content will include requirements for wiring and installation of electrical devices, auxiliary gutters, raceways, fuses and over-current devices, wire devices, hazardous locations, busways, residential calculation and applicable national electrical code.

>APR210G - Plumbing Apprenticeship Residential Installation

Credits - 4 Lecture - 4

This course will introduce the plumbing apprentice to the broad variety of fixtures (tubs, showers, toilets, water heaters etc.) and fixture fittings (faucets, valves, trim, regulators, gauges) found in residential, commercial and industrial building and instruct the apprentice in the Code requirements and industry practices for proper use and installation.

>APR210H - Plumbing Apprenticeship Commercial Installation

Credits - 4 Lecture - 4

This course will allow the apprentice to master more complex mathematical calculations encountered in the trade; understand the principles of heat transfer and heat retention in connection with water heaters; and understand methods of water treatment as it applies to the Plumbing trade.

>APR210I - Plumbing Apprenticeship Code

Credits - 4 Lecture - 4

This course the Plumbing apprentice will master the concepts and procedures of reading a complete set of plans; basic electricity; installation of storm drains; and the Uniform Plumbing Code as it relates to the Plumbing industry.

>APR210J - Plumbing Apprenticeship Industrial Installation

Credits - 4 Lecture - 4

This course the Plumbing Apprentice will gain proficiency in; service and maintenance of residential, commercial and industrial plumbing primarily focusing on industrial plumbing installation and repair; and associated Uniform Plumbing Codes for industrial installations.

>APR210K - Plumbing Apprenticeship Basic Waste Water System

Credits - 4 Lecture - 4

This course will enable the Plumbing Apprentice to gain proficiency in isometric drawings to depict sizing in water, drainage and gas piping systems; direct, indirect and special waste system; protection of water supply - sources of possible contamination, prevention devices and practices; principles of hydraulics and pneumatic related to plumbing; pump theory - installation and maintenance; developing shop drawings and figuring materials for a job.

>APR210L - Plumbing Apprenticeship Code and Test Prep

Credits - 4 Lecture - 4

This course covers the review of the Uniform Plumbing Code designed to assist the apprentice with various aspects of taking and passing the Oregon Plumbing License exam.

Course Descriptions

>APR211G - LMPE Apprenticeship Safety and Code

Credits - 4 Lecture -4

This course covers the technical knowledge of the skills required of an LMPE Electrician. Content will cover applied electrical theory, residential and commercial wiring practices, busways, motor fundamental application National Electrical Code.

>APR211H - LMPE Apprenticeship Motors and Controls

Credits - 4 Lecture -4

This course will allow the LMPE Electrical apprentice to understand the technical knowledge of the skills required including motors, generators, controls, and applicable National Electrical Code.

>APR211I - LMPE Apprenticeship Fiber Optics

Credits - 4 Lecture -4

This course covers applied electrical theory, fiber optics, specialty applications, residential and commercial wiring practices, busways, motor fundamentals, and applicable National Electrical Code for electrical installations.

>APR211J - LMPE Apprenticeship Math/Test Equipment

Credits - 4 Lecture -4

This course covers related training for LMPE Electrician apprentice. Content includes trade history, safety and first aid, blueprint reading, commercial and residential calculations, wiring methods, related theory and National Electrical Code.

>APR211K - LMPE Apprenticeship Voltage

Credits - 4 Lecture -4

This course covers a thorough review of the National Electrical Code book. Theory and application of motor controls, solid state fundamentals, special termination, layout, hazardous locations and transformer locations.

>APR211L - LMPE Apprenticeship Code and Test Prep

Credits - 4 Lecture -4

This course covers the review of the National Electrical Code designed to assist the apprentice with various aspects of taking and passing the Oregon State Limited Manufacture Plant Electrical License exam.

>APR212G - Inside Electrical Apprenticeship Safety and Code

Credits - 4 Lecture -4

This course covers the technical knowledge of the skills required of an Inside Wire Electrician. Content will cover applied electrical theory, residential and commercial wiring practices, busways, motor fundamental application National Electrical Code.

>APR212H - Inside Electrical Apprenticeship Motors and Controls

Credits -4 Lecture - 4

This course will allow the apprentice to understand the technical knowledge of the skills required including motors, generators, controls, and applicable National Electrical Code.

>APR212I - Inside Electrical Apprenticeship Fiber Optics

Credits -4 Lecture - 4

This course covers applied electrical theory, fiber optics, specialty applications, residential and commercial wiring practices, busways, motor fundamentals, and applicable National Electrical Code for electrical installations.

>APR212J - Inside Electrical Apprenticeship Math/Test Equipment

Credits -4 Lecture - 4

This course covers related training for Inside Wire Electrician apprentice. Content includes trade history, safety and first aid, blueprint reading, commercial and residential calculations, wiring methods, related theory and National Electrical Code.

>APR212K - Inside Electrical Apprenticeship Voltage

Credits -4 Lecture - 4

This course covers a thorough review of the National Electrical Code book. Theory and application of motor controls, solid state fundamentals, special termination, layout, hazardous locations and transformer locations.

>APR212L - Inside Electrical Apprenticeship Code and Test Prep

Credits -4 Lecture - 4

This course covers the review of the National Electrical Code designed to assist the apprentice with various aspects of taking and passing the Oregon State Electrical License exam.

>APR214D - PLC Apprenticeship Operation

Credits -4 Lecture - 4

This course covers related training for Programmable Logic Controller (PLC) apprentices to study theory and trade practices content focused on automatic control systems, accuracy, errors, pressure measurement and measurement principles.

>APR214E - PLC Apprenticeship Troubleshooting

Credits -4 Lecture - 4

This course covers related training for Programmable Logic Controller (PLC) apprentice to study theory and trade practices with content focused on compensation, temperature measurement, pneumatic principles, and control, valves, automatic control, and troubleshooting the system.

>APR214F - PLC Apprenticeship Practical Applications

Credits - 4 Lecture - 4

This course covers related training for Programmable Logic Controller (PLC) apprentices to study theory and trade practices with content focused on calibration, errors, control valves, and special programmable controller functions.

>APR215D - LME Apprenticeship Safety and Code

Credits - 4 Lecture - 4

This course covers the technical knowledge of the skills required of an LME Electrician. Content will cover applied electrical Theory, residential and commercial wiring practices, busways, motor fundamental application National Electrical Code.

>APR215E - LMPE Apprenticeship Motors and Controls

Credits - 4 Lecture - 4

This course will allow the LME Electrical apprentice to understand the technical knowledge of the skills required including motors, generators, controls, and applicable National Electrical Code.

>APR215F - LME Apprenticeship Code and Test Prep

Credits - 4 Lecture - 4

This course covers the review of the National Electrical Code designed to assist the LME Electrical apprentice with various aspects of taking and passing the Oregon State Limited Maintenance Electrical License exam.

*ART101 - Introduction to Visual Arts

Credits - 3 Lecture - 3

Addresses seeing, experiencing, and appreciating the world through architecture, gardens, fountains, and public spaces. Examines how communities express the values, technology, geography, and economic structure of many different cultures in the light of aesthetic, historic, and critical factors.

*ART102 - Introduction to Visual Arts

Credits - 3 Lecture - 3

Addresses painting and sculpture in terms of experiencing, appreciating, and understanding their role in our lives. Art is examined in the light of aesthetic, historic, and critical issues.

*ART103 - Introduction to Visual Arts

Credits - 3 Lecture - 3

Addresses issues relating to design in our daily lives including commercial, industrial, crafts, and product design. Examines how design expresses the values, technology, economy, and taste of our culture in light of aesthetic, historic, and critical factors.

*ART115 - Basic Design

Credits - 3 Lecture -2 Lab -1

The hands-on study of composition, structure and arrangements of various components for all aesthetic creation. An important foundation class for any designer. Emphasis given to the elements and principles of design learned by practical applications through experimentation in a variety of medium and art forms.

*ART116 - Basic Design

Credits - 3 Lecture -2 Lab -1

A non-sequential course exploring more medium and art forms in learning the fundamentals of arrangements for art and design creations, this course features hands-on study of composition, structure and arrangements of various components for all aesthetic creation. An important foundation class for any designer. Emphasis given to the elements and principles of design learned by practical applications through experimentation in a variety of medium and art forms.

*ART117 - Basic Design

Credits - 3 Lecture -2 Lab -1

A non-sequential course exploring more medium and art forms in learning the fundamentals of arrangements for art and design creations, this course features hands-on study of composition, structure and arrangements of various components for all aesthetic creation. Emphasis on the elements and principles of design learned by practical applications through experimentation in a variety of medium and art forms.

Symbols: ^ - Elective + - Lab Science
* - Group Distribution > - C/T Elective

Course Descriptions

***ART131 - Beginning Drawing**

Credits - 3 Lecture -2 Lab -1

A studio hands-on experience introducing basic procedures, media, and styles in drawing. Subject matter including people, animals, still life, and landscape will be experienced. Guidelines and steps on how to draw an image including shading, establishing perspective, and accurate portions are presented.

***ART132 - Beginning Drawing**

Credits - 3 Lecture -2 Lab -1

A non-sequential course featuring hands-on experience introducing basic procedures, media, and styles in drawing. Subject matter including people, animals, still life, and landscape will be experienced. Guidelines and steps on how to draw an image including shading, establishing perspective, and accurate portions are presented.
Prerequisite: ART131

***ART133 - Beginning Drawing**

Credits -3 Lecture - 2 Lab -1

A non-sequential course featuring hands-on experience introducing basic procedures, media, and styles in drawing. Subject matter including people, animals, still life, and landscape will be experienced. Guidelines and steps on how to draw an image including shading, establishing perspective, and accurate portions are presented.
Prerequisite: ART131, 132

***ART154 - Beginning Ceramics**

Credits -3 Lecture - 2 Lab -1

Introduction to the materials, methods and techniques of pottery design and construction.

***ART155 - Beginning Ceramics**

Credits -3 Lecture - 2 Lab -1

A non-sequential course that is an introduction to the materials, methods and techniques of pottery design and construction.

***ART156 - Beginning Ceramics**

Credits -3 Lecture - 2 Lab -1

A non-sequential course that is an introduction to the materials, methods and techniques of pottery design and construction.

***ART184 - Beginning Watercolor**

Credits -3 Lecture - 2 Lab -1

Methods, materials, composition, and techniques using aqueous media.

***ART185 - Watercolor**

Credits -3 Lecture - 2 Lab -1

A non-sequential course featuring methods, materials, composition, and techniques using aqueous media.

***ART186 - Watercolor**

Credits -3 Lecture - 2 Lab -1

A non-sequential course featuring methods, materials, composition, and techniques using aqueous media.

^ART198 - Special Studies

Credits -1-3

Individualized study in areas not considered in other courses to meet special interest or program requirements. Complete a term project approved by the instructor. Course is repeatable up to 2 times.(2-6 credits total.)

Recommended preparation: Prior study and instructor approval.

***ART204 - History of Western Art**

Credits -3 Lecture - 3

A history of the visual arts in the Western world. This course surveys developments in painting, sculpture, and architecture from the Prehistoric period through the Byzantine era.

***ART205 - History of Western Art**

Credits - 3 Lecture - 3

A history of visual arts in the Western world. This course surveys developments in painting, sculpture, and architecture from Romanesque period through the Renaissance up to the Baroque and Rococo.

***ART206 - History of Western Art**

Credits - 3 Lecture - 3

A history of visual arts in the Western world. This course surveys developments in painting, sculpture and architecture from the Neoclassical period through the developments of the 20th Century.

***ART222 - Graphic Design**

Credits - 3 Lecture - 2 Lab - 1

Typography, layout design, computer graphics. Offers study and practice in the principles and processes of graphic communication and production concept design to camera-ready art.

***ART223 - Graphic Design**

Credits - 3 Lecture - 2 Lab - 1

Intermediate course in principles and process of graphic design communication. Offered periodically.

***ART231 - Intermediate Drawing**

Credits - 3 Lecture - 2 Lab - 1

A studio hands-on experience extending basic procedures, media, and styles in drawing from that learned in ART 131. Subject matter including people, animals, still life, and landscape will be experienced. Guidelines and steps on how to draw an image including shading, establishing perspective, and accurate portions are presented.
Prerequisite: ART131

***ART232 - Intermediate Drawing**

Credits - 3 Lecture - 2 Lab - 1

A studio hands-on experience extending basic procedures, media, and styles in drawing from that learned in ART 132. Subject matter including people, animals, still life, and landscape will be experienced. Guidelines and steps on how to draw an image including shading, establishing perspective, and accurate portions are presented.
Prerequisite: ART132, ART231

***ART233 - Intermediate Drawing**

Credits - 3 Lecture - 2 Lab - 1

A studio hands-on experience extending basic procedures, media, and styles in drawing from that learned in ART 133. Subject matter including people, animals, still life, and landscape will be experienced. Guidelines and steps on how to draw an image including shading, establishing perspective, and accurate portions are presented.
Prerequisite: Art133, ART232

***ART254 - Intermediate Ceramics**

Credits - 3 Lecture -2 Lab -1

A continuation of ART 154 in the introduction to the materials, methods and techniques of pottery design and construction at the intermediate level.

Prerequisite: ART154

***ART255 - Intermediate Ceramics**

Credits - 3 Lecture -2 Lab -1

A non-sequential continuation of ART 155 in the introduction to the materials, methods and techniques of pottery design and construction at the intermediate level.

Recommended preparation: ART155

***ART256 - Intermediate Ceramics**

Credits - 3 Lecture -2 Lab -1

A non-sequential continuation of ART 156 in the introduction to the materials, methods and techniques of pottery design and construction at the intermediate level.

Recommended preparation: ART156

***ART261 - Beginning Photography**

Credits - 3 Lecture -2 Lab -1

Black and white photographic processes and techniques; development of camera and darkroom skills; seeing photographically.

***ART262 - Digital Photo Imaging**

Credits - 3 Lecture -2 Lab -1

Studio course introducing the concepts, techniques, practices, aesthetics, and ethics of photographic imaging and image making with digital technologies. Includes experimentation with the camera and the digital darkroom. Methods include capturing, color correcting and balancing, retouching, layering, masking, composition, and output for printing or digital media presentation.

***ART263 - Beginning Photography**

Credits - 3 Lecture -2 Lab -1

A non-sequential course continuing to introduce and reinforce the concepts, techniques, practices, aesthetics, and ethics of photographic imaging and image making with digital technologies. Includes experimentation with the camera and the digital darkroom. Methods include capturing, color correcting and balancing, retouching, layering, masking, composition, and output for printing or digital media presentation.

***ART264 - Intermediate Photography**

Credits - 3 Lecture -2 Lab -1

Intermediate black and white photographic processes and techniques; further development of camera and darkroom skills; seeing photographically.

Instructor approval required.

***ART265 - Intermediate Photography**

Credits -3 Lecture - 2 Lab -1

A non-sequential course continuing the intermediate black and white photographic processes and techniques; further development of camera and darkroom skills; seeing photographically.

Instructor approval required.

***ART266 - Intermediate Photography**

Credits -3 Lecture - 2 Lab -1

A non-sequential course continuing the intermediate black and white photographic processes and techniques; further development of camera and darkroom skills; seeing photographically.

Instructor approval required.

***ART276 - Beginning Sculpture**

Credits -3 Lecture - 2 Lab -1

A hands-on introduction to studio sculpture through exploring various styles, techniques, and materials of three-dimensional artistic creation. Experiences also include mold making and casting.

Course Descriptions

***ART277 - Beginning Sculpture**

Credits -3 Lecture - 2 Lab -1

A non-sequential course featuring the hands-on introduction to studio sculpture through exploring various styles, techniques, and materials of three-dimensional artistic creation. Experiences also include mold making and casting.

***ART278 - Beginning Sculpture**

Credits -3 Lecture - 2 Lab -1

A non-sequential course featuring the hands-on introduction to studio sculpture through exploring various styles, techniques, and materials of three-dimensional artistic creation. Experiences also include mold making and casting.

***ART281 - Beginning Painting**

Credits -3 Lecture - 2 Lab -1

A hands-on studio introduction to painting in either oils or acrylic. Exploration in many techniques, styles, and subjects. Includes information on color theory and beginning paint mixing procedures.

***ART282 - Beginning Painting**

Credits -3 Lecture - 2 Lab -1

A non-sequential course featuring hands-on studio introduction to painting in either oils or acrylic. Exploration in many techniques, styles, and subjects. Includes information on color theory and beginning paint mixing procedures.

***ART283 - Beginning Painting**

Credits -3 Lecture - 2 Lab -1

A non-sequential course featuring hands-on studio introduction to painting in either oils or acrylic. Exploration in many techniques, styles, and subjects. Includes information on color theory and beginning paint mixing procedures.

***ART284 - Intermediate Painting**

Credits - 3 Lecture - 2 Lab - 1

A non-sequential course featuring hands-on studio introduction to painting in either oils or acrylic. Exploration in many techniques, styles, and subjects. Includes information on color theory and beginning paint mixing procedures.
Prerequisite: ART281,282, 283

***ART285 - Intermediate Painting**

Credits - 3 Lecture - 2 Lab - 1

A non-sequential course featuring hands-on studio introduction to painting in either oils or acrylic. Exploration in many techniques, styles, and subjects. Includes information on color theory and beginning paint mixing procedures.

***ART286 - Intermediate Painting**

Credits - 3 Lecture - 2 Lab - 1

A non-sequential course featuring hands-on studio introduction to painting in either oils or acrylic. Exploration in many techniques, styles, and subjects. Includes information on color theory and beginning paint mixing procedures.

***ART291 - Intermediate Sculpture**

Credits - 3 Lecture - 2 Lab - 1

A non-sequential course continuing the ART 278 skills at the intermediate level featuring the hands-on introduction to studio sculpture through exploring various styles, techniques, and materials of three-dimensional artistic creation. Experiences also include mold making and casting.

***ART292 - Intermediate Sculpture**

Credits - 3 Lecture - 2 Lab - 1

A non-sequential course continuing the ART 278 skills at the intermediate level featuring the hands-on introduction to studio sculpture through exploring various styles, techniques, and materials of three-dimensional artistic creation. Experiences also include mold making and casting.

***ART293 - Intermediate Sculpture**

Credits - 3 Lecture - 2 Lab - 1

A non-sequential course continuing the ART 278 skills at the intermediate level featuring the hands-on introduction to studio sculpture through exploring various styles, techniques, and materials of three-dimensional artistic creation. Experiences also include mold making and casting.

^ART298 - Special Studies

Credits - 1-3

Advanced, individualized study in areas not considered in other courses to meet special interests or program requirements. Complete a term project approved by the instructor. Course is repeatable up to 2 times.(2-6 credits total.)
Instructor approval required.

^BA101 - Introduction to Business

Credits - 4 Lecture -4

Introduction to business organization, operation, marketing, management, and finance. Course is designed to help students choose their field of major concentration.

>BA104 - Business Mathematics

Credits - 4 Lecture -4

A study of banking applications, fractions, percentages, payrolls, commissions, trade and cash discounts, markup, simple interest, notes and interest variables, and charges for credit.
Recommended preparation: MTH025

>BA105 - Business Mathematics

Credits - 4 Lecture -4

A study of inventories, depreciation, financial statement analysis, stocks and bonds, compound interest, present and future value.
Recommended preparation: BA104

>BA110A - Business Computer Application/MS Access

Credits - 3 Lecture - 2 Other - 1

Basic application and utilization of MS Access database software to solve business computing problems. Focus will include designing and building a database, applying queries, creating reports, using forms, and advanced printing.
Recommended preparation: BA131 and OA120

>BA110X - Business Computer Applications/MS Excel

Credits - 3 Lecture -2 Lab -1

Basic application and utilization of MS Excel spreadsheet software to solve business computing problems. Focus will include developing a worksheet, changing formats/appearance, using formulas, creating charts, and advanced printing.
Recommended preparation: BA131 and MTH025

>BA111 - Basic Accounting

Credits - 4 Lecture - 3 Other - 1

Provides a basic understanding of debits and credits and financial statements for service enterprises and merchandising businesses.

>BA113 - Credit Procedures

Credits - 3 Lecture -3

Principles of consumer and commercial credit management. Covers types of credit instruments, sources of information, collection. and control.

>BA116 -Bookkeeping Practice

Credits - 2 Other - 2

A hands-on practice set designed to give the student experience with current accounting software.

^BA131 - Introduction to Business Computing

Credits -4 Lecture - 3 Lab -1

General orientation to computer operations and literacy, along with an insight into the broad impact of computers and their uses in today's society. The fundamentals of using the Microsoft Windows operating system, email, web browsers, word processing, spreadsheets, and databases will be developed through hands-on use in the computer lab.

Recommended preparation: OA120 or instructor approval

>BA155 - Introduction to Fraud Examination

Credits -3 Lecture - 3

An introduction to how and why occupational fraud is committed, how fraudulent conduct can be deterred, and how allegations of fraud should be investigated and resolved.

>BA177 - Payroll Accounting

Credits -4 Lecture - 3 Other - 1

Introduction to personnel and payroll records, including all current Federal and State payroll taxes. Provides ample practice in preparation of payroll records by hand and by using a computerized payroll accounting software.
Recommended preparation: Accounting class

^BA198 -Special Studies

Credits -1-3

Designed to provide interested and capable students with the opportunity to study special topics in business areas.
Instructor approval required.

^BA206 - Principles of Management

Credits -4 Lecture - 4

Principles of management and their applications in organization, administration, and production in the business environment.

>BA207 -E-Commerce

Credits -4 Lecture - 4

This is a comprehensive 4-credit course designed to prepare the business professional for a challenging role in today's national and international online markets.

>BA209A - Accounting Applications

Credits -3 Lecture - 2 Other - 1

Completion of accounting practice sets varying from simple to complex on the computer using Peachtree software.

>BA209P - Accounting Applications/Payroll

Credits -4 Lecture - 2 Other - 2

Completion of payroll accounting practice sets varying from simple to complex on the computer using Peachtree and/or QuickBooks software.
Recommended preparation: Accounting class with a C or better.

Symbols: ^ - Elective	+ - Lab Science
* - Group Distribution	> - C/T Elective

Course Descriptions

>BA209Q - Accounting Applications/ QuickBooks

Credits - 3 Lecture - 2 Other - 1

Computerized accounting using QuickBooks software, an integrated computerized accounting package relating to service and merchandising businesses.

Recommended preparation: Accounting class with a C or better.

>BA210 - Microcomputer Applications - Advanced Excel

Credits - 3 Lecture - 2 Lab - 1

Advanced application and utilization of MS Excel program software to solve business problems by modeling advanced spreadsheets commonly used in the business world.

Prerequisite: BA110X

^BA211 - Principles of Accounting

Credits - 4 Lecture - 3 Other - 1

Introduction to accounting including techniques of account construction, preparation of financial statements, application of accounting principles to practical business problems, and proprietorship studies.

^BA212 - Principles of Accounting

Credits - 4 Lecture - 3 Other - 1

A continuation of BA 211. Emphasis is on corporations and managerial accounting.

Prerequisite: BA211 with C grade or better.

^BA213 - Principles of Accounting

Credits - 4 Lecture - 3 Other - 1

A continuation of BA 212 with emphasis on managerial accounting.

Prerequisite: BA211 and BA212 with C grade or better.

^BA214 - Business Communications

Credits - 3 Lecture - 3

Concepts and skills necessary to write clean, concise business prose including letters, memos, and reports for standard business uses. Some time is also devoted to oral communications relevant to the business community. The purpose of this course is to help students develop skills to write clean, concise business correspondence and to enter the job market with the appropriate skills knowledge. The course will emphasize skills applicable to both the job search and on-the-job skills. Prerequisite: WR121 (typing or word processing skills strongly recommended)

Recommended preparation: OA121 and WR121

>BA215 - Cost Accounting

Credits - 4 Lecture - 3 Other - 1

The design and development of cost systems, cost analysis, and management use of cost information.

>BA220 -Tax Accounting

Credits - 4 Lecture - 3 Other - 1

Designed to assist students in becoming proficient in preparing federal and State of Oregon individual tax returns. Upon successful completion of this course and BA 221, students will meet the state educational requirements for the Oregon Licensed Tax Preparer's test.

>BA221 - Accounting Problems/Tax

Credits - 4 Lecture - 3 Other - 1

A continuation of BA 220. Combined with BA 220, this class prepares the student to sit for the Oregon Licensed Tax Preparer's test.

>BA222 -Finance

Credits - 3 Lecture - 4

This course covers an introduction to financial markets in which funds are traded, the institutions which participate in and facilitate these flows of funds and principles, and concepts of financial management which guide the student in making sound financial decisions.

>BA223 - Principles of Marketing

Credits - 4 Lecture - 4

General survey of the nature and role of marketing with emphasis on products, pricing, distribution, and promotion.

>BA224 - Human Resources Management

Credits - 3 Lecture - 3

Introduction to the field of human resources management covering staffing, wage and salary administration, fringe benefits, training and orientation, testing and evaluation, labor relations and unions, and personnel research.

Prerequisite: BA206 or instructor approval.

^BA226 - Business Law

Credits - 4 Lecture - 4

The origins of law; the relations of business to society and the law; the evolution of business within the framework of the law, and the development and present-day applications of the law to contracts, sales, and agencies.

>BA238 - Personal Selling

Credits - 3 Lecture - 3

General sales techniques involving successful personal selling of goods, services, or ideas which includes discussion of motives, sales psychology, prospecting for customers, and sales techniques.

>BA239 - Retail Promotion

Credits - 3 Lecture - 3

A general survey of the field of retail promotion including the study of retail advertising, display, layout, and the selection of appropriate media.

>BA249 - Retail Selling

Credits -3 Lecture - 3

General sales techniques involving the factors of successful selling of retail goods and services including retail buying motives, sales psychology, customer approach, and retail sales techniques.

>BA251 - Office Management

Credits -3 Lecture - 3

Introduction to the field of office management covering problems in staffing, training, work standards, layout of offices, supervision, pay and benefits, working conditions, and staff motivation.

>BA261 - Intermediate Accounting

Credits -4 Lecture - 3 Other - 1

Continues the study of accounting principles, the theory underlying the determination of income, and the presentation of financial statements.

>BA262 - Intermediate Accounting

Credits -4 Lecture - 3 Other - 1

Continues the study of accounting principles, the theory underlying the determination of income, and the presentation of financial statements.

>BA263 - Intermediate Accounting

Credits -4 Lecture - 3 Other - 1

Continues the study of accounting principles, the theory underlying the determination of income, and the presentation of financial statements.

>BA265 - Accounting Problems

Credits -4 Lecture - 3 Other - 1

An advanced course dealing with accounting problems in the areas of partnership, branch offices, and governmental accounting.

>BA268 - Introduction to Auditing

Credits -3 Lecture - 3

Basic principles and procedures of the examination of financial statements as well as the principles involved in obtaining audit proofs applicable to any audit functions.

>BA271 - Analyzing Financial Statements

Credits -3 Lecture - 3

Includes accounting characteristics of financial statements and the analysis of each component.

>BA277 -Business Ethics

Credits -3 Lecture - 3

Ethical aspects and practices of business and professional organizations and their employees including a brief introduction to traditional theories of ethics.

^BA280 - Cooperative Work Experience

Credits - 1-8

Provides an experience in the business work environment. A maximum of 12 credits can be earned in any one school year.

Instructor approval required.

>BA284 - Pre-Employment Seminar

Credits - 1 Lecture - 1

Designed to assist the student in resume and cover letter preparation, interviews, application forms, employment searches, and helpful techniques in obtaining, holding, and advancing in a job.

>BA285 - Human Relations in Business

Credits - 3 Lecture - 3

Designed to develop effective human relations in the workplace including: achieving a deepened sense of awareness of self and others, interpersonal communication skills, motivation, valuing diversity, and organizational politics.

^BA298 - Special Studies

Credits - 1-3

Provides interested and capable students the opportunity to study special topics in the field of business.

Instructor approval required.

BI080 - Anatomy and Physiology

Credits - 3 Lecture - 3

Anatomy and Physiology is the study of the structures of the body and how these structures normally function. Emphasis is on a systemic approach to the study of human anatomy and physiology.

*+BI101 - General Biology

Credits - 4 Lecture - 3 Lab - 1

A survey course in biological science which fulfills the laboratory science requirement for non-science majors. Topics include biochemistry, cells, genetics, and evolution. Need not be taken in sequence.

Symbols: ^ - Elective	+ - Lab Science
* - Group Distribution	> - C/T Elective

Course Descriptions

*+BI102 - General Biology

Credits - 4 Lecture - 3 Lab - 1

A part of the general biology sequence. Topics covered include: cell physiology, classification of viruses, bacteria, protists, fungi and plants, and plant anatomy and physiology. Need not be taken in sequence.

*+BI103 - General Biology

Credits - 4 Lecture - 3 Lab - 1

A part of the general biology sequence. Topics covered include animal taxonomy, physiology, behavior, and ecology. Need not be taken in sequence.

*+BI124 - Global Ecology and Conservation Biology

Credits - 4 Lecture - 3 Lab - 1

Introduction to ecology including a multidisciplinary investigation of the ways humans interact with habitats worldwide. Course fulfills the laboratory science requirement for non-science majors. Offered periodically.

*+BI149 - Human Genetics

Credits - 3 Lecture - 3

An introductory lecture course in genetics with emphasis on human aspects. Topics include cellular basis of genetics, Mendelian inheritance, evolutionary genetics, and the molecular basis of inheritance. Offered periodically.

*+BI162 - Selected Topics in Natural History

Credits - 4 Lecture - 3 Lab - 1

The course covers the field study of natural environments. The course may be repeated for credit with different subtitles. The specific title of the course offered in any given term will be listed in the class schedule. Course fulfills lab science requirement. Offered periodically.
Instructor approval required.

*+BI163 - Natural History of Oregon

Credits - 4 Lecture - 3 Lab - 1

Introduction to Oregon's biogeographic provinces. The organisms, communities, geology, and the interactions of these to form the different provinces will be studied. Extended field trips will be taken. Course fulfills lab science requirement. Offered periodically.
Instructor approval required.

^BI198 - Special Studies

Credits - 1-3

Provides interested and capable students the opportunity to study special topics in the field of biology.
Instructor approval required.

*+BI211 - General Biology

Credits - 5 Lecture - 4 Lab - 1

A class designed for students majoring in the biological and allied science areas. Topics are cell anatomy and physiology, genetics, and evolution. Need not be taken in sequence.
Recommended corequisite: CH121 or CH221

*+BI212 - General Biology

Credits - 5 Lecture - 4 Lab - 1

Subjects covered are evolution, animal taxonomy, anatomy & physiology, behavior and ecology. Need not be taken in sequence.

*+BI213 - General Biology

Credits - 5 Lecture - 4 Lab - 1

Course deals with taxonomy of bacteria, viruses, protists, fungi and plants, plant anatomy and physiology, and ecology. Need not be taken in sequence.

*+BI231 - Human Anatomy and Physiology

Credits - 4 Lecture - 3 Lab - 1

A study of the structures of the systems of the human organism. Systems emphasized include the skeletal, muscular cardiovascular, urinary, and digestive systems.

*+BI232 - Human Anatomy and Physiology

Credits - 4 Lecture - 3 Lab - 1

The functional aspects of the human organism are emphasized. Topics include neuron function, skeletal muscle physiology, cardiovascular physiology, and transport mechanisms.
Prerequisite: BI231

*+BI233 - Human Anatomy and Physiology

Credits - 4 Lecture - 3 Lab - 1

A study of the structure and function of prokaryotic and eukaryotic cells. Topics include: reproduction, protein synthesis, enzymology, and immune functions.
Prerequisite: BI232

*+BI234 - Microbiology

Credits - 4 Lecture - 3 Lab - 1

An introductory course in microbiology, with emphasis on anatomy and physiology of bacteria, fungi and viruses, and proper techniques for handling and studying microorganisms.

*+BOT221 - Systematic Botany

Credits - 4 Lecture - 3 Lab - 1

An introductory course in plant systematics with emphasis placed on the proficient use of Hitchcock's "Flora of the Pacific Northwest." The recognition characteristics of plant families plus the identification of local plants is stressed in this course. This is a field course.

>BT101 - Office Careers Survey

Credits - 1 Lecture - 1

A survey of employment opportunities in the area served by BMCC. Includes the education requirements for various types of jobs, working conditions, salaries, opportunities for advancement, and available on-the-job training.

>BT116 - Office Procedures

Credits - 3 Lecture - 3

An overview of business etiquette, interoffice relations, business customs, routines, tasks and procedures, self-appraisal and careers in the electronic office.

>BT120 - Computer Keyboarding

Credits - 2 Other - 2

Touch typing on the computer keyboard on alphabet keys with emphasis on improving the student's speed and accuracy. Students are given individualized skill-building exercises using computer-assisted instruction.

>BT121 - Keyboarding

Credits - 3 Lecture - 2 Other - 1

This is a beginning course designed for the beginning student. The major objectives of this course are to build basic speed and accuracy skills; and provide practice in applying those basic skills to the production of letters, reports, tables, memos, forms and other kinds of personal, personal-business, and business communication.

>BT122 - Keyboarding

Credits - 3 Lecture - 2 Other - 1

This course promotes the further development of basic keyboarding skills and emphasizes the production of a wide range of typical business correspondence, tables, reports, and forms from unarranged and rough-draft sources. The jobs students prepare and the formats they use are based on current software practices. Basic desktop publishing is introduced. Skill-building is stressed to increase speed to a minimum of 40 words per minute.

>BT123 - Keyboarding

Credits - 3 Lecture - 2 Other - 1

This course contains a brief review of basic production techniques. Integrated office projects emphasize and provide practice in applying such modern office skills as editing, abstracting, decision-making, setting priorities, following directions, and working under pressure with interruptions. Skill-building is continued to increase speed to a minimum of 50 words per minute.

>BT124 - Applied Keyboarding

Credits - 3 Other - 3

BT124 Keyboarding will help develop your speed and accuracy using a computer. You will use a thoroughly tested skill-building program to measure your keyboarding speed and accuracy and to determine any specific keyboarding problems you might have by analyzing diagnostic tests that you will take. This course will help you to meet hiring criteria for words per minute on an employment test.

>BT131 - Legal Office Procedures

Credits - 3 Lecture - 3

This course is a practical, comprehensive course that prepares legal assistant students for the law office environment.

>BT140 - Business Document Editing

Credits - 3 Lecture - 2 Other - 1

Review of grammar and proofreading skills needed in preparing business documents using word processing software and equipment.

>BT201M - Word Processing/MS Word

Credits - 3 Lecture - 2 Other - 1

Basic application and utilization of MS Word software to solve business computing problems. Focus includes creating and formatting documents, editing, merging documents, using columns, and adding graphics.

>BT201W - Word Processing I/WordPerfect

Credits - 3 Lecture - 2 Other - 1

Instruction in the use of WordPerfect software. Emphasis is placed on creating, formatting, editing, margining business documents, text columns and elementary graphics.

Symbols: ^ - Elective + - Lab Science
* - Group Distribution > - C/T Elective

Course Descriptions

>BT202M - Word Processing/MS Word

Credits - 3 Lecture - 2 Other - 1

Advanced application and utilization of MS Word software to solve business computing problems. Focus includes collaboration of documents, adding comments, tracking changes, saving versions, completing complex merges, building macros, advanced graphics, and integrating Excel charts, Access tables and PowerPoint slide shows.

>BT202W - Word Processing II/WordPerfect

Credits - 3 Lecture - 2 Other - 1

Intermediate instruction in the use of WordPerfect software. Features include developing footnotes, headers, text columns, macros and graphics.

>BT204 - Advanced Word Processing

Applications

Credits - 3 Lecture - 2 Other - 1

Advanced training in the use of word processing software. Various business documents are produced using advanced procedures to do more complex merges, text columns, tables with math, macros and graphics. Comprehensive training continues in editing and formatting using multiple documents in Windows.

>BT206 - Desktop Publishing

Credits - 3 Lecture - 2 Other - 1

Applications of software in basic desktop publishing to create various business and personal documents. Extensive use of fonts and graphics will be used in documents designed and created by the student. Previous experience in application software strongly recommended.

>BT220 - Calculating Machines

Credits - 3 Lecture - 2 Other - 1

Operation of electronic printing calculators using touch fingering to do mathematical problems involving addition, subtraction, multiplication, division, percentages, constant factors, multiple factors, accumulation of products and quotients, negative multiplication, exponents, decimal equivalents, and reciprocals.

>BT225 - Machine Transcription

Credits - 2 Other - 2

Development of skills in the transcription of recorded dictation using word processing software to produce mailable business correspondence.

>BT226 - Advanced Machine Transcription

Credits - 2 Other - 2

A continuation of BT 225 with increasing levels of difficulty in specialty areas.

>BT230 - Legal Terminology

Credits - 3 Lecture - 3

This course is a practical, comprehensive course that prepares legal assistant students for the law office environment.

>BT231 - Legal Transcription

Credits - 3 Lecture - 2 Other - 1

Development of skill in the transcription of recorded legal dictation using word processing software to produce legal documents and correspondence.

>BT240 - Records Management

Credits - 3 Lecture - 3

Effective methods and systems of storing and retrieving business information, managerial considerations necessary for an efficient records management program and qualifications needed for a career in records management.

>BT251 - Medical Terminology

Credits - 3 Lecture - 3

Medical terms that pertain to body systems, anatomical structures, medical processes and procedures and a variety of diseases which are part of a specialized language that the health care team uses to communicate concisely and accurately.

>BT252 - Medical Terminology

Credits - 3 Lecture - 3

A continuation of BT 251 with particular emphasis on medical terminology pertaining to the body systems.

>BT253 - Medical Transcription

Credits - 3 Other - 3

Introduction to transcription of medical office and hospital records including histories, physicals, radiology and pathology reports, consultations, operative reports, discharge summaries and autopsies.

>BT254 - Medical Transcription

Credits - 3 Other - 3

A continuation of BT 253 designed to develop expertise in transcribing medical records in specialty areas.

>BT255 - Medical Transcription

Credits - 3 Other - 3

A continuation of BTv 254 designed to develop expertise in transcribing medical records in additional specialty areas. Includes background noise and dictation by speakers with foreign accents.

>BT257 - Medical Office Procedures

Credits - 3 Lecture - 2 Other - 1

An office practice simulation designed to emphasize routine medical office procedures including medical vocabulary and spelling, medical ethics, medical telephone procedures, medical records management and medical transcription and coding.

>BT258 - Medical Insurance Procedures and Coding

Credits - 3 Lecture - 3

Medical insurance records management for private health and accident insurance, Medicare, Medicaid, Workers' Compensation. Emphasizes abstracting information from health records for billing and transfer forms. Includes introductory use of CPT-4 and ICD-9M coding.

>BT280 - Cooperative Work Experience

Credits - 1-8

Provides an experience in the business work environment which complements classroom instruction. A maximum of 12 credits can be earned in any one school year.

>BT290 - Integrated Office Systems

Credits - 3 Lecture - 2 Other - 1

This is a capstone course for students who are completing the final term of a two-year AAS degree. The course includes a simulated office experience for students in a practical application of skills and concepts acquired in all business programs. Microsoft Office software and use of the internet is applied.

>CET074 - Technical Communications

Credits - 3 Lecture - 3

A course which focuses on the combined use of oral, written, and graphic communication skills to prepare comprehensive technical reports based on a comprehensive investigative or design project. *Prerequisite: SP100 and WR065*

>CET111 - Introduction to Engineering Technology

Credits - 3 Lecture - 3

An orientation course for engineering technicians presenting the historical development of engineering as a profession and related issues of ethics, careers and licensing. Introduction to problem solving format, dimensional analysis and the hand held calculator through the application of algebra based mathematics.

Instructor approval required.

>CET112 - Computer Aided Drafting

Credits - 3 Other - 3

An introduction to computer aided drafting using AutoCAD software, including design set up, file management, entity creation, and manipulation. Projects will include orthographic projection, sections, dimensioning, and isometric drawings.

>CET113 - Advanced Computer Aided Drafting

Credits - 3 Other - 3

Advanced CAD applications utilizing reference files, symbols/cell libraries and work space setup in the development of drawings for civil structural purposes and building projects including buildings, bridges, site plans, subdivisions and highway design projects using the Microstation software.

Prerequisite: CET112

>CET114 - Introduction to Geographic Information Systems

Credits - 3 Other - 3

An introduction to the fundamentals of geographic information systems (GIS) including a brief history of automated mapping, and basic cartographic principles including map scales/coordinate systems/map projections. Hands on use of computer-based ESRI Software will introduce the concepts of layering data from multiple sources into a coherent system. Applicable to geography, sciences, agriculture, business, and engineering uses.

>CET145 - Engineering Graphics

Credits - 3 Other - 3

An introduction to design processes, graphical analysis, and solutions using fundamental graphic communication concepts including sketching, lettering, geometric constructions, projection theory, orthographic drawing, dimensioning, sections, and pictorial representation.

Course Descriptions

>CET152 -Materials of Construction

Credits - 2 Lecture -2

The physical characteristics, production and testing methods of materials used in engineering construction.

>CET162 -Engineering Materials

Credits - 3 Lecture -3

Basic properties, behavior and survey of engineering applications of materials.

>CET205 -Structural Drafting

Credits - 3 Other - 3

Layout and detailing of timber, steel, and reinforced concrete structural elements using manual and computer-aided drafting procedures.

Prerequisite: CET112, CET145 or instructor approval.

>CET215 -Contract Documents

Credits - 4 Lecture - 3 Other - 1

Interpreting contract documents emphasizing civil law as it relates to contract administration, plans and specifications, and effects on construction practice.

>CET222 - Concrete Practices

Credits - 4 Lecture -3 Lab -1

CET 222 incorporates the areas of study covered in CET 222A, CET 222B and CET 222C.

CET222A - Concrete Field Testing Technician

Credits -1 Lecture - 1

A study of the Basics of Concrete relating to the testing of fresh concrete. Material prepares students for completion of the ACI-Field Testing Technician I and ODOT Quality Control Technician Certification Requirements.

CET222B - Concrete Control Technician

Credits -1 Lecture - 1

A study of the Fundamental of Mix Design, review of the Basics of Concrete and in-depth investigation of the properties of concrete materials. Students are instructed in the Absolute Volume Method of Mix Design and the techniques required to meet job site specifications for concrete. Material prepares students for complete of the ODOT Concrete Control Technician Certification Requirements.

CET222C - Concrete Strength Testing Technician

Credits -1 Lecture - 1

Material prepares students for completion of the ACI -Concrete Strength Testing Technician Certification Requirements.

>CET223 - Soil Mechanics

Credits -3 Lecture - 2 Lab -1

Introduction to soils as engineering materials. Includes classification, evaluation of various physical properties using index tests, and the engineering significance of those properties. Introduction to foundations and excavations.

>CET231 - Structures

Credits -4 Lecture - 3 Lab -1

Evaluation of stress-strain relationships as related to engineering materials, with emphasis on timber and steel. Includes analysis of structural members and their connections, torsion on power-transmitting shafts, and centroids and moments of inertia of stress.

Prerequisite: GS104 or PHY201 or PHY211

>CET235 - Structures

Credits -4 Lecture - 3 Lab -1

Design of simple beams and columns utilizing an analysis of stress-strain relationships as related to engineering materials, with emphasis on timber and steel. Analysis of structural members and their connections, torsion on power transmitting shafts, centroids and moments of inertia of stress.

Prerequisite: CET231

>CET242 - Structures

Credits -4 Lecture - 3 Lab -1

Utilization of LRFD design methods for design of basic concrete structures with emphasis on singly reinforced flexural members including rectangular beams, T-beams, floor slabs, and walls.

Prerequisite: CET235

>CET251 - Estimating Construction

Costs

Credits - 4 Lecture - 3 Lab - 1

Study of processes related to scheduling, estimating and codes in construction. Includes CPM, Quantity Take-Off, Labor-Time and bidding procedures.

Prerequisite: CET215

>CET261 - Hydraulics

Credits - 4 Lecture - 3 Other -1

Introduction to fluid mechanics with emphasis on basic principles of incompressible fluids and their practical application to fluids at rest, steady flow of liquids in closed conduits and open channels, head losses in pipe flow and flow measuring devices.

Prerequisite: PH211, PHY201 or GS104

>CET263 - 3-D Computer Aided Drafting

Credits - 3 Other - 3

An advanced course using 3-D CAD environment on the Microstation platform to create solid models of objects and buildings. Includes operations to utilize sheet files, materials, palettes, sectioning tools, and exporting tools.

Prerequisite: CET113

>CET280 - Cooperative Work Experience

Credits - 1-8

Supervised production drafting and related work in governmental and private offices.

Instructor approval required.

*+CH104 - Elementary Chemistry

Credits - 5 Lecture - 4 Lab - 1

A medically oriented chemistry sequence for students seeking admission to a nursing or allied health program. A prerequisite for both the licensed practical nurse (LPN) and associate degree nurse (ADN), the course is a study of general, organic, and biochemistry which applies to nursing or allied health.

Prerequisite: MTH060

*+CH105 - Elementary Chemistry

Credits - 5 Lecture - 4 Lab - 1

This is a continuation of CH 104, and is a medically oriented chemistry sequence for students seeking admission to a nursing or allied health program. A prerequisite for both the licensed practical nurse (LPN) and associate degree nurse (AND), the course is a study of general, organic, and biochemistry which applies to nursing or allied health.

Prerequisite: CH104

*+CH106 - Elementary Chemistry

Credits - 5 Lecture -4 Lab -1

This is a continuation of CH 105, and is a medically oriented chemistry sequence for students seeking admission to a nursing or allied health program. A prerequisite for both the licensed practical nurse (LPN) and associate degree nurse (AND), the course is a study of general, organic, and biochemistry which applies to nursing or allied health.

Prerequisite: CH105

*+CH121 -College Chemistry

Credits - 5 Lecture -4 Lab -1

The first term of an introductory course in general, inorganic, organic, and biochemistry. This sequence fulfills the prerequisite for organic chemistry.

Prerequisite: MTH065 or instructor approval.

*+CH122 -College Chemistry

Credits - 5 Lecture -4 Lab -1

A continuation of CH 121, this is the second term of an introductory course in general, inorganic, organic, and biochemistry. This sequence fulfills the prerequisite for organic chemistry.

Prerequisite: CH121

*+CH123 -College Chemistry

Credits - 5 Lecture -4 Lab -1

A continuation of CH 122, this is the second term of an introductory course in general, inorganic, organic, and biochemistry. This sequence fulfills the prerequisite for organic chemistry.

Prerequisite: CH122

*+CH221 - General Chemistry

Credits - 5 Lecture -4 Lab -1

Professional course for students majoring in chemistry, dentistry, veterinary science, pharmacy, engineering, medicine, forestry, and related sciences or for non-science majors wanting a more rigorous mathematical course than the CH 121 sequence.

Corequisite: MTH111

*+CH222 - General Chemistry

Credits - 5 Lecture -4 Lab -1

This continuation of CH 221 is a professional course for students majoring in chemistry, dentistry, veterinary science, pharmacy, engineering, medicine, forestry, and related sciences or for non-science majors wanting a more rigorous mathematical course than the CH 121 sequence.

Prerequisite: CH221

*+CH223 - General Chemistry

Credits -5 Lecture - 4 Lab -1

This continuation of CH 222 is a professional course for students majoring in chemistry, dentistry, veterinary science, pharmacy, engineering, medicine, forestry, and related sciences or for non-science majors wanting a more rigorous mathematical course than the CH 121 sequence.

Prerequisite: CH222

Symbols: ^ - Elective	+ - Lab Science
* - Group Distribution	> - C/T Elective

Course Descriptions

***+CH241 -Organic Chemistry**

Credits -5 Lecture - 4 Lab -1

A laboratory course in organic chemistry for students majoring in chemistry, dentistry, veterinary science, pharmacy, engineering, medicine, forestry and related sciences. Covers the chemistry of aliphatic and aromatic organic compounds emphasizing mechanistic pathways. Lecture and laboratory work highly correlated. Offered periodically.

Prerequisite: CH121-123 or CH221-223

***+CH242 -Organic Chemistry**

Credits -5 Lecture - 4 Lab -1

This laboratory course in organic chemistry for students majoring in chemistry, dentistry, veterinary science, pharmacy, engineering, medicine, forestry and related sciences is a continuation of CH 241.

Covers the chemistry of aliphatic and aromatic organic compounds emphasizing mechanistic pathways. Lecture and laboratory work highly correlated. Offered periodically.

Prerequisite: CH241

***+CH243 -Organic Chemistry**

Credits -5 Lecture - 4 Lab -1

This laboratory course in organic chemistry for students majoring in chemistry, dentistry, veterinary science, pharmacy, engineering, medicine, forestry and related sciences is a continuation of CH 241.

Covers the chemistry of aliphatic and aromatic organic compounds emphasizing mechanistic pathways. Lecture and laboratory work highly correlated. Offered periodically.

Prerequisite: CH242

^CJ100 - Survey of Criminal Justice

Credits -3 Lecture - 3

An introductory survey of the functional areas of the criminal justice system in the United States including police, courts, and correctional processes.

^CJ101 - Introduction to Criminology

Credits -3 Lecture - 3

The study of crimes from a sociological perspective, and crime control strategies suggested by these causes.

^CJ107 - Criminal Justice Seminar

Credits -3 Lecture - 3

A study of the current criminal justice problems and methods of alleviating them.

^CJ110 - Introduction to Law Enforcement

Credits - 3 Lecture - 3

An in-depth study of the role and responsibilities of law enforcement in American society. A look at the historical development, role concept and conflicts, professionalization, use of discretion, current enforcement practices and career opportunities.

^CJ111 - Concepts of Enforcement Services

Credits - 3 Lecture - 3

A study of the concepts, theories, and principles of police operations. In-depth studies of specific aspects of police operations, such as traffic, equipment, use of force, and community policing.

^CJ114 - Gender, Race, Class and Crime

Credits - 3 Lecture - 3

Provides criminal justice students with an understanding of multicultural diversity and how it interrelates with practices and policies of police, judicial systems, and corrections. The understanding of differences for the criminal justice professional, agency, policies for cultural sensitivity, peacekeeping and professionalism are explored, as well as the study of gender, race and class relative to their contributions to crime.

^CJ115 - Culture of Guns and Violence in America

Credits - 3 Lecture - 3

A study of the moral, legal, and ethical aspects of deadly force and the role of firearms in American society.

^CJ120 - Judicial Process

Credits - 3 Lecture - 3

A study of the judicial and social processes from arrest through appeal. Analysis of the duties and roles of each member of the courtroom workgroup.

^CJ122 - Oregon Law

Credits - 3 Lecture - 3

The elements, purpose and functions of criminal, traffic, and juvenile laws for the State of Oregon.

^CJ130 - Introduction to Corrections

Credits - 3 Lecture - 3

A study of contemporary correctional institutions and detention facilities; organization and personnel programs and activities; inmate society and trends; and career orientation.

^CJ132 - Introduction to Probation and Parole

Credits - 3 Lecture - 3

An introduction to the use of probation and parole as a means of controlling criminal offenders within the community. The course includes the philosophy, historical development and contemporary functioning of parole and probation agencies and officers.

^CJ198 - Special Studies

Credits - 1-3

Designed to provide interested and capable students with the opportunity to study special topics in criminal justice.

^CJ200 - Police and Public Policy

Credits - 3 Lecture -3

Contemporary study of the American police. The effect of political influence on the police, interaction with other governmental components, and the dilemma of balancing public safety and civil liberty.

^CJ201 - Juvenile Delinquency

Credits - 3 Lecture -3

Study of deviant behavior and current criminological theories, with emphasis on crime prevention and the phenomena of crime as it relates to juveniles and criminal justice applications.

^CJ204 - Behavioral Cognitive Processes

Credits - 4 Lecture - 3 Other - 1

This course is designed to provide an understanding of cognitive processes to changing offender behavior, its role and application with offenders in correctional programming (rehabilitation and recidivism) and how it can effect criminal behavioral change. Laboratory will consist of actual on-site correctional programming.

^CJ207 - Criminal Justice Seminar

Credits - 3 Lecture -3

A study of the current criminal justice problems and methods of alleviating them.

^CJ210 - Criminal Investigation

Credits - 3 Lecture -3

Study of basic principles of all types of investigations in the justice system. Handling of crime scenes and recognition and preservation of different types of evidence, investigative techniques unique to specific types of crime, interview and interrogation techniques, and case management and preparation for prosecution.

^CJ215 - Criminal Justice Administration

Credits - 3 Lecture -3

Supervision of police personnel and administration of a criminal justice agency including budgets, finance, care and handling of equipment, recruitment and discipline.

^CJ220 - Criminal Law

Credits - 3 Lecture -3

Survey and analysis of substantive criminal law and defenses to criminal prosecution. Emphasis on the law, crimes and statutory ramifications. Case method is used.

^CJ222 - Criminal Procedure and Evidence

Credits -3 Lecture - 3

Theory and practice of the criminal justice system from arrest to release including: due process, right of counsel, arrests, search and seizure, wiretapping and electronic eavesdropping, confession, and lineups. Case method is used.

^CJ225 - Correctional Law

Credits -3 Lecture - 3

Explores several historical and current cases involving inmate crimes and/or malpractice with inmates. Prisoners' rights as well as correctional staff rights are examined, along with emerging trends resulting from recent court cases.

^CJ226 - Constitutional Law

Credits -3 Lecture - 3

A study of basic principles of the United States Constitution with emphasis on leading Supreme Court cases and the Bill of Rights.

^CJ232 - Correctional Casework Counseling

Credits -3 Lecture - 3

Basic concepts of interviewing and counseling techniques used by correctional officers in one-to-one contacts with clients. Rudimentary skills practiced through role playing and demonstration prepare the student for practice in the field and an appreciation of further training.

Course Descriptions

^CJ243 - Narcotics and Dangerous Drugs

Credits -3 Lecture - 3

The role of substance use and abuse in society, especially as it impacts on crime.

^CJ280 - Cooperative Work Experience

Credits -1-8

Supervised field experience in a criminal justice or related agency. An in-service student may pursue a research project instead of work in the field. Includes a seminar for discussion of problems and experience gained.

Instructor approval required.

CS020 - Computer Orientation

Credits -1 Other - 1

This course is designed for those who have had little or no experience working with computers. The purpose of the course is to introduce students to computer language and basic computer use with an emphasis on word processing and using e-mail.

CS080 - Introduction to Personal Computers

Credits - 3 Lecture - 3

The student will examine the applications and use of personal computer hardware and software. The student will be introduced to word processing, e-mail, spreadsheets, and the Internet. Also discussed is basic file management under Windows.

CS090 - Personal Computer Applications

Credits - 3 Lecture - 3

This class will introduce the student to one particular software package on a Macintosh or IBM compatible microcomputer. Students may repeat this course under different topics.

CS095 - Personal Computer Applications

Credits - 3 Lecture - 3

A continuation of the topics covered in CS 090. Students may repeat the course under different topics.

***CS120 - Concepts of Computing**

Credits - 4 Lecture - 4

A survey of the general concepts of computers and their applications. Concepts include computer systems, system and applications software, data organization and management, and computers in society. Specific applications with hands-on projects will include word processing, presentation management, spreadsheets, database, graphics, and web authoring.

^CS125 - Software Applications

Credits - 3 Lecture - 3

This class will study in detail one specific software application used with microcomputers. Topics will include standard features and operations of the application and consideration of one or more specific products and their unique features. Course may include (but is not limited to) word processing (CS 125W), spreadsheets (CS 125S), presentation management (CS 125P), multimedia (CS 125M), database management systems (CS 125D), desktop publishing (CS 125B) and e-mail (CS 125E). This course may be repeated under different topics. Offered periodically

***CS133B - Programming with Visual Basic**

Credits - 4 Lecture - 4

An introduction to programming with the high level programming language Visual BASIC. The student will study basic programming styles, techniques and the syntax of Visual BASIC. Students will write, run and debug programs on microcomputers.

***CS133U - Programming with C++**

Credits - 4 Lecture - 4

An introduction to programming with the high level programming language C. The student will study basic programming styles, techniques and the syntax of C. Students will write, run and debug programs on microcomputers.

***CS161 - Computer Science**

Credits - 4 Lecture - 4

An introduction to problem solving and algorithm design with the use of a high level programming language. Included will be basic principles of hardware, software and programming techniques.

Recommended preparation: MTH111 or equivalent.

***CS162 - Computer Science**

Credits - 4 Lecture - 4

A continuation of CS 161. Additional topics may include data organization (multidimensional arrays, records, pointers, lists, stacks and queues) and techniques for designing large projects.

Prerequisite: CS161

^CS179 - Introduction to Networking

Credits - 4 Lecture -3 Lab -1

This class introduces the students to basic computer networking concepts. Networking topologies, basic hardware and software components in network, the OSI protocol model, and vocabulary items are presented to the students.

^CS180 - Computer Science Practicum

Credits - 4

A course that will allow students to apply what they have learned in some area of computer science to real world situations. Students will work directly with a local business or organization under the direction and supervision of their instructor. Offered periodically.

***CS195 - Web Development**

Credits - 4 Lecture -4

A first course in the design and development of Web pages and sites. This course will include the use of Web page authoring tools as well as HTML syntax to create Web pages. Students will study both the mechanics and practical application of these tools as well as principles of good design for the Web.

Recommended preparation: CS120

^CS198 - Special Studies

Credits - 1-3

This course is designed to provide interested and capable students special topics in computer science.

***CS260 - Data Structures**

Credits -4 Lecture - 3 Other - 1

A continuation of CS 162 including basic data structures, searching and sorting techniques and advanced problem solving. Offered periodically.

Prerequisite: CS162

^CS279 - Network Management II

Credits -4 Lecture - 3 Other - 1

The class introduces the student to Local Area Network Management. Some topics taught in this course include setting up users, directory structures, security issues, printing and print queues, login scripts, and other management tools available for networking administrators. Students will manage a small LAN system with supervisory rights during the tenure of the course.

^CS280 - Cooperative Work Experience

Credits -1-8

Provides a supervised work experience in computer science which supplements the "school experience", that is not possible in the normal academic classroom environment.

Instructor approval required.

^CS288 - Network Management III

Credits -4 Lecture - 3 Lab -1

A course designed to examine different advanced networking topics and current trends in networking. Topics will include items relative to the needs and learning experience of the students.

***CS295 - Web Development**

Credits -4 Lecture - 4

A second course in the design and development of Web pages and sites. This course will include JavaScript, CCS, SSI, CGI programming, and other DHTML tools. Students will study both the mechanics and practical application of these tools. Recommended preparation: CS195

^CS298 - Special Studies

Credits -1-3

This course is designed to provide interested and capable students special topics in computer science.

Instructor approval required.

>CSS100 - Soils and Fertilizers

Credits -3 Lecture - 2 Lab -1

Students will study and evaluate the characteristics of the soil. Soil amendments and fertilizers are reviewed to determine crop requirements. Plant and soil analysis techniques are studied.

>CSS201 - Principles of Crop Science

Credits - 3 Lecture - 3

Covers the major farm practices used in Eastern Oregon. Major crops used to facilitate learning include wheat, barley, peas, potatoes, and corn. Other crops will be reviewed to determine their adaptability to local climate, soils, and markets. Cooperative work experience required.

>CSS210 - Forage Crops

Credits - 3 Lecture - 3

Students will study the various crops raised for livestock consumption. Proper planting, maintenance, harvest, and storage techniques, production and economic returns are topics reviewed in detail. Cooperative work experience required.

Corequisite: AGR280

Symbols: ^ - Elective + - Lab Science
* - Group Distribution > - C/T Elective

Course Descriptions

>CSS240 - Pest Management

Credits - 4 Lecture - 4

Students will study the common pesticides used on today's farms and ranches. Herbicides, insecticides, fungicides, and growth regulators will be reviewed. Methods of application and calibration are taught stressing safety in handling and disposal. Cooperative work experience required.
Corequisite: AGR280

>DA141 - Dental Radiology

Credits - 4 Lecture - 3 Lab - 1

Introduces dental radiology concepts including historical background, terminology, principles of dental radiology, legal aspects regarding use of radiation, basic physics associated with x-rays and biological effects of x-rays. Includes practical instruction on and sizes health and safety, infection control procedures, anatomical landmarks, types and sizes of x-ray film, darkroom processing, film mounting, examination and operation of a dental x-ray unit with beginning practice of film placement and exposure techniques on mannequins.
Admission to the dental program and/or instructor approval.

>DA142 - Dental Radiology

Credits - 3 Lecture - 2 Lab - 1

Continued study and clinical practice with the principles of dental radiography techniques including: bisecting, paralleling, bitewing, panoramic exposure on adult patients, and other exposure techniques for the edentulous patient. The identification of possible abnormalities seen on a radiograph are viewed and discussed.
Prerequisite: DA141

>DA143 - Dental Radiology

Credits - 1 Lab - 1

Provides a concentrated clinical application of dental radiographic procedures studied in previous courses in preparation for the Dental Assisting National Board Radiation Examinations.
Prerequisite: DA142

>DA151 - Chairside Procedures

Credits - 3 Lecture -2 Lab -1

Introduction to and practice of basic chairside assisting procedures including disease transmission, disinfection and sterilization procedures, OSHA compliance procedures, patient preparation, oral evacuation, equipment and instrument identification, instrument transfer, and restorative operative dental procedures.
Admission to the dental program and/or instructor approval.

>DA152 - Chairside Procedures

Credits - 3 Lecture -2 Lab -1

A presentation of the theory and practice of new procedures and review of oral evacuation, instrument transfer, and infection control procedures. Includes discussion, demonstration, and practical application of the following: alginate impressions, dental dam placement and removal, bite registration, suture removal, introduction to tofflemire matrix and wedge placement, and coronal polish.
Prerequisite: DA151

>DA153 - Chairside Procedures

Credits - 2 Lecture -1 Lab -1

Covers theory and practice of procedural responsibilities delegated to the dental auxiliary as outlined in the current Oregon Dental Practice Act for the Expanded Function Duty Assistant. Includes discussion, demonstration, practical lab experience, and clinical application.
Prerequisite: DA142, 152, 162

>DA154 - Dental Specialties

Credits - 2 Lecture -2

Covers various specialties of dentistry and new, emerging technologies, their principal procedures, instrument identification, tray setups, and post-operative care instructions.
Prerequisite: DA151

>DA161 - Clinical Practice

Credits - 2 Other - 2

Students will be given weekly research questions on various topics covered during fall term. Research questions are to be completed using information obtained while observing in local dental facilities. When appropriate, students may begin to assist with basic procedures with instructor's permission, and the dentist's supervision.
Admission to the dental program and/or instructor approval.

>DA162 - Clinical Practice

Credits - 4 Other - 4

Course designed to provide supervised clinical experience in basic chairside assisting procedures, including material manipulation, oral evacuation, instrument transfer, charting, and patient management in a local dental office.
Prerequisite: DA151

>DA163 - Clinical Practice

Credits -8 Other - 8

Provides dental assisting students with continued supervised work experience in a dentist's office. Students assist with operative procedures, exposing and processing dental radiographs, dental laboratory procedures, and performing business office procedures.
Prerequisite: DA162

>DA166 - Clinical Practice Seminar

Credits -1 Lecture - 1

Seminar discussions to be held on various aspects of spring term internships in local dental offices. Employment opportunities, resume' writing, completing job applications, and interviewing skills are covered.
Admission to the dental program and/or instructor approval.

>DA170 - Basic Dental Science

Credits -3 Lecture - 3

The study of systems of the human body, their physiology, as well as bacteriology and embryology as they relate to the oral cavity.
Admission to the dental program and/or instructor approval.

>DA172 - Dental Anatomy

Credits -4 Lecture - 4

An introduction to the oral cavity. Students will identify the supporting structures, differences, and similarities of individual teeth of both primary and permanent dentition. Utilizing various numbering systems, students will gain skill and knowledge of basic charting symbols and procedures. Blacks' Cavity classification and elements of cavity design are introduced.

Admission to the dental program and/or instructor approval.

>DA174 - Dental Pathology

Credits -1 Lecture - 1

The study of oral pathology to include normal, diseased, or injured tissues; dental caries; oral inflammation; abscesses, and developmental abnormalities.

Prerequisite: DA170 and DA172

>DA176 - Dental Pharmacology

Credits -1 Lecture - 1

General aspects of pharmacology; sources, types, purposes, and composition of the drugs. Course includes methods of prescribing and administering various drugs as well as local anesthetics used by the dentist when treating patients.
Admission to the dental program and/or instructor approval.

>DA180 - Dental Materials

Credits -3 Lecture - 2 Lab -1

Introduction, demonstration, manipulation, and principal application including physical and chemical properties, preparation, care and storage of materials used in dental offices.
Admission to the dental program and/or instructor approval.

>DA182 - Dental Materials and Procedures

Credits - 2 Lecture - 1 Lab - 1

Introduction to a variety of materials used in the dental office for restorative and specialized procedures. The course includes the various materials, physical and chemical properties, preparation, manipulation, care and storage, as well as laboratory equipment identification, use and safety procedures.
Prerequisite: DA151 and DA180

>DA190 - Dental Health Education

Credits - 2 Lecture - 2

The attitudes, philosophies, and behaviors of the dental patients along with techniques to motivate and manage their various behaviors. Covers basic concepts of preventive dentistry including the study of plaque-related diseases, brushing and flossing techniques, and fluoride therapy. Basic food groups and nutritional counseling are introduced along with techniques for preparing and evaluating dental health education materials.
Admission to the dental program and/or instructor approval.

>DA192 - Dental Law and Ethics

Credits - 1 Lecture - 1

History, ethics, and legal aspects of dentistry are covered as they are prescribed the American Dental Association and Oregon Practice Act. Designed to acquaint students with the members of the dental team, their roles, educational background, and legal responsibilities and restrictions.
Prerequisite: DA190

Course Descriptions

>DA194 - Dental Business Office

Credits - 3 Lecture - 2 Other - 1

Designed to prepare the student for management of the dental office, including the study of business office procedures and techniques, written communication, computer use, dental insurance, accounts receivable, recall systems, staff and patient management, and inventory control procedures.

Prerequisite: DA162

>DA196 - Medical Emergencies in the Dental Office

Credits - 1 Lecture - 1

Emphasizes the importance of the health history, treatment of the medically compromised patient, and the influence a medical emergency may have on the patient during clinical treatment. Signs and symptoms are studied for handling medical emergencies. Course content also includes vital signs and emergency medical equipment usage.

Admission to the dental program and/or instructor approval.

>DSL141 - Heavy Duty Steering and Suspension

Credits - 4 Lecture - 3 Lab - 1

This course will prepare the student to diagnose and repair problems with manual and power steering components, suspension systems, steerable tag and drop axles. The course will also train students in preventative maintenance practices for steering and suspension systems and for steering and suspension system alignment.

>DSL151 - Heavy Duty Brakes I

Credits - 3 Lecture - 2 Other - 2

Hydraulic, air, and mechanical brake system principles of operation, self-energizing, drum, disc, parking, internal expanding, and external band brakes will be covered. Brake system self-adjusters, electric brakes, brake adjustment and inspection will also be covered. Included in this course will also be engine brakes and retarders.

>DSL152 - Manual Drive Transmissions I

Credits - 3 Lecture - 2 Other - 2

Principles and operation of power train components including automotive and industry applications of clutches, drive lines, and gear transmissions. Transmission of force through the mechanism will be studied in theory and in labs. Detailed maintenance and repair of drive lines, clutches, gear transmissions, and transaxles with emphasis on problem diagnosis, repair and replacement.

>DSL153 - Manual Drive Transmissions II

Credits - 3 Lecture - 2 Other - 2

A continuation of DSL 152 covering more detailed maintenance and repair of drive lines, differentials, transfer cases, gear transmissions, and transaxles with emphasis on problem diagnosis, repair and replacement, and repair.

>DSL161 - Diesel Engines

Credits - 3 Lecture - 2 Lab - 1

This course will prepare the student to have a thorough understanding of the principles and operation of the oil-fired, compression-ignition, diesel engine. Topics covered will include the design, construction, operation, diagnosis, service, and repair of both mobile and stationary diesel engines.

>DSL162 - Engine Repair I

Credits - 3 Lecture - 2 Lab - 1

Detailed study of disassembly and inspection of an internal combustion engine. Students will study materials used in construction, function, and purpose of each unit, its upkeep and overhaul.

>DSL175 - Heavy Duty Equipment

Credits - 3 Lecture - 2 Lab - 1

This course will focus on off-highway mobile equipment systems. Training will emphasize diagnostics and repair of heavy equipment.

>DSL176 - Mobile Air-Conditioning and Heating

Credits - 3 Lecture - 2 Lab - 1

This course will introduce the theory of air conditioning and heating systems in mobile equipment. The theory will be followed by diagnostic and repair techniques required by the service technician.

>DSL181 - Shop Practices

Credits - 3 Lecture - 3

This course trains the student in basic shop environment practices, including personal safety. The course also trains student in proper and safe tool use, along with use of fasteners and hardware employed in the field of diesel technology.

>DSL184 - Fluid Mechanics

Credits - 4 Lecture - 3 Lab - 1

This course will introduce the theory and application of fluid mechanics. The course expands upon the theory by troubleshooting and repairing on- and off-highway hydraulic systems.

>DSL191 - Electrical Systems I

Credits - 4 Lecture - 2 Other - 2

An introductory course designed to provide basic technical knowledge of principles of operation, construction, and purpose of electron theory and basic electrical circuits and components.

>DSL192 - Electrical Systems II

Credits - 4 Lecture - 2 Other - 2

Provides the basic technical knowledge of electrical circuits, measurement values, circuit components, circuit tracing and diagnosing, and repair of electrical malfunctions.

>DSL193 - Electrical Systems III

Credits - 4 Lecture - 2 Other - 2

Designed to give the student basic technical knowledge of semiconductors and diodes, including operating principles of starting, charging, and ignition systems.

>DSL196 - Electronics Diagnosis

Credits - 3 Lecture - 2 Lab - 1

Operating principles, adjustments, testing and maintenance of computer controlled systems using modern test equipment and procedures. Computerized fuel, braking, transmissions, and monitoring systems will be covered.

>DSL241 - Frames, Couplings, Trailers

Credits - 3 Lecture - 2 Lab - 1

This course is designed for students who are training to enter the workforce with entry level skills in the heavy-duty truck, trailer, bus, and equipment repair business. The course focuses on developing maintenance and repair skills in the area of vehicle frames, trailers, tractor/trailer combinations and coupling devices by intensive classroom lecture and virtual workplace lab work. The student will learn to identify various types of equipment and components, and how to properly repair and maintain equipment.

>DSL251 - Heavy Duty Brakes II

Credits - 3 Lecture - 2 Other - 2

Principles of compressed air, air brake component identification and operation, and air brake valve troubleshooting and service will be covered. This course also includes other heavy duty brake systems for trucks, tractors and heavy equipment; and complete brake jobs, including inspection and service.

>DSL262 - Engine Repair II

Credits - 3 Lecture - 2 Lab - 1

This course will emphasize the operation, construction and assembly of an internal combustion engine. Troubleshooting and common operating problems will be discussed.

>DSL280 - Cooperative Work Experience

Credits - 1-8

Provides a supervised work experience in diesel mechanics which supplements the "school experience", that is not possible in the normal academic classroom environment. Instructor approval required.

*EC198 - Special Studies

Credits - 1-3

This course is designed to provide interested and capable students special topics in economics. Instructor approval required.

*EC201 - Principles of Economics/Micro

Credits - 3 Lecture - 3

Introduction to Micro Economics. Focuses on the behavior of individual consumers and business firms and how their interaction leads to a set of prices that act to allocate scarce resources among alternative uses.

*EC202 - Principles of Economics/Macro

Credits - 3 Lecture - 3

Introduction to Macro Economics. Focuses on the behavior of economic aggregates or the economy as a whole. National income determination, measuring economic performance and public policy tools for dealing with inflation, unemployment, etc. are discussed.

*EC203 - Principles of Economics/Theory

Credits - 3 Lecture - 3

Applications of Economic Theory. Applies the economic theory learned in EC 201 and EC 202 to current economic problems.

>ECE100 - Developmentally Appropriate Practice in Early Childhood Ed

Credits - 3 Lecture - 3

This course covers an overview of developmentally appropriate practice in early childhood education.

Symbols: ^ - Elective	+ - Lab Science
* - Group Distribution	> - C/T Elective

Course Descriptions

>ECE101 - Family and Community Relations

Credits - 3 Lecture -3

This course provides the knowledge and skills necessary to work effectively with families and community professionals in early childhood education. Topics to be covered include family involvement, communicating with families and professionalism in early childhood education.

>ECE111 - Introduction to Early Childhood Education/Environments

Credits - 3 Lecture -3

This course covers the different types of early childhood education programs and the regulations that govern each. Students will evaluate a variety of ECE settings utilizing standardized assessment tools based on principles of developmentally appropriate practice.

>ECE112 - Introduction to Early Childhood Education/ Professionalism

Credits - 1 Lecture -1

This course covers employability and career development.

>ECE113 - Introduction to Early Childhood Education/Child Advocacy

Credits - 1 Lecture -1

This course covers the ethical and legal responsibilities of early childhood practitioners.

>ECE150 - Observation/Assessment and Recording

Credits - 3 Lecture -3

Students will develop skills necessary to observe, assess and record young children's behavior. Students will gain experience with a variety of observation and recording tools. Focus is on the importance of objective record keeping in relationship to the on-going monitoring of children's development.

>ECE151 - Guidance and Classroom Management

Credits - 3 Lecture -3

This course is an introduction to managing behavior in the classroom. Emphasis is on why misbehavior occurs, and practical strategies to deal with those behaviors.

>ECE152 - Creativity for Young Children

Credits - 3 Lecture -3

This course focuses on understanding and implementing developmentally appropriate practices for the young child. Students will gain hands-on experience in multiple creative activities that are age appropriate, individually appropriate, and culturally appropriate.

>ECE153 - Music and Movement

Credits -3 Lecture - 3

This class provides a foundation for understanding the role of music and movement in the development of young children. Students will have the opportunity to integrate knowledge and experience culminating in a personal collection of developmentally appropriate music and movement activities for young children.

>ECE154 - Literature and Literacy

Credits -3 Lecture - 3

This course surveys and presents methods for using and evaluating children's literature. Students will also gain knowledge about the relationship between language development and emergent literacy.

>ECE161 - Practicum/Infants and Toddlers

Credits -4 Lecture - 2 Lab -2

Practica are individualized, community placements in early childhood education settings with direct supervision. They provide a formalized experiential learning opportunity for students considering an early childhood profession. Practicum/Infants & Toddlers provides students the opportunity to work with children from birth to three; Practicum/Preschool focuses on children from three to five.

>ECE163 - Practicum/Preschool

Credits -4 Lecture - 2 Lab -2

Practica are individualized, community placements in early childhood education settings with direct supervision. They provide a formalized experiential learning opportunity for students considering an early childhood profession. Practicum/Infants & Toddlers provides students the opportunity to work with children from birth to three; Practicum/Preschool focuses on children from three to five. *Instructor approval required.*

>ECE175A - First By Five/Social Emotional Growth

Credits -1 Lecture - 1

This course presents healthy social emotional development in infancy as the underpinning for all other learning and that social emotional development is dependent on the child's close relationship with respectful, caring adults. Also discussed is the importance of understanding temperament, emotions, environmental impact and care giving responsiveness to the child's needs. Students are presented information to promote awareness of their own feelings, expectations and attitudes brought with them from past experiences to the field of early childhood education. Students will examine the relationship between social emotional care giving and services provided to families.

>ECE175B - First By Five/Group Care

Credits - 1 Lecture - 1

This course helps students to understand how to develop intimacy between infants and others in a group. Students will discuss barriers, as well as discover strategies for providing appropriate care. Respectful routine care in a child's daily life is fundamental to developing intimate relationships. Students will evaluate health and safety issues, daily routine care and consider environment, space and child care ratios as important aspects of group care.

>ECE175C - First By Five/Learning and Development

Credits - 1 Lecture - 1

This course presents a non-traditional view of how infants and toddlers develop. Students will discover the importance of infants and toddlers having the freedom to make learning choices and to experience the world on their own terms. Facilitation of natural interests and urges to learn dominate the course content with specific information based on understanding learning schemes, developmental stages and support for learning.

>ECE175D - First By Five/Culture, Family and Provider

Credits - 1 Lecture - 1

This course challenges students to articulate their philosophy of infant/toddler care and the caregiver-parent relationship so that they can develop stronger partnerships and facilitate communication with parents. Considerations for how participants can encourage families to participate in their child's care will be discussed and strategies for working with difficult situations explored. The course will also examine common challenges in conducting a child care business to include defining business relationships and arrangements. Family issues around separation, accepting diversity, culture and routine care and culture and child development will be analyzed and practical solutions explored.

>ECE198 - Special Studies

Credits - 1-3

Designed to provide interested and capable students with the opportunity to study special topics in the Early Childhood Education program.

>ECE226 - Child Development

Credits - 3 Lecture - 3

This course covers child development birth through age six. Focus is on major developmental theories, stages of development and appropriate behavioral expectations. This course is the foundation for the Early Childhood Education program.

>ECE227 - Enhancing Social Emotional Development

Credits - 3 Lecture - 3

This course provides an in-depth exploration of strategies and techniques for enhancing children's social emotional development.

>ECE240 - Curriculum/Planning

Credits - 3 Lecture -3

This course focuses on designing curriculum for the young child using the principles of developmentally appropriate practices across developmental domains. Students will learn to construct lesson plans from a variety of perspectives including creative, emergent, thematic, anti-bias, cultural and emotional wellbeing.

>ECE245 - Challenging Behavior in Young Children

Credits - 3 Lecture -3

This course addresses challenging behavior in young children. Students will explore the causes of and the risk factors associated with challenging behavior. Students will develop knowledge and skills which will allow them to understand, prevent, and respond effectively to challenging behavior.

>ECE248 - Overview of Special Services

Credits - 3 Lecture -3

This course introduces students to services for early intervention to young children with special needs. The course also presents current legislation, educational needs of special children and ideas and strategies for working with families to integrate special children into preschool programs.

Course Descriptions

>ECE249 - Inclusion of Children with Special Needs

Credits - 3 Lecture -3

The emphasis of this course is on strategies and adaptations for including children with special needs in the early childhood setting. Current resources and best practices for educating children with diverse abilities, limited English proficiency, different socioeconomic and/or cultural backgrounds and other special needs will be explored.

>ECE258 - Multicultural Education

Credits - 3 Lecture -3

This course covers the philosophy, activities, and techniques appropriate to a culturally sensitive classroom. Students will develop an understanding of the impact of culture on individual perception and learning and group dynamics.

>ECE280 - Cooperative Work Experience

Credits - 1-8

The purpose of cooperative work experience is to provide students with an opportunity to gain volunteer experience with young children in an early childhood setting. Students participating in cooperative work experience with young children must successfully complete a criminal history background check. Cooperative work experience may include one-to-one or small group instructional assisting.
Instructor approval required.

>ECE295 - Child Care Administration >ED125 - Peer Tutoring/ED 125 >ED229 - Learning and Development

Credits -3 Lecture - 3

An exploration of administrative roles and responsibility in child care centers. Topics include philosophy, finances, personnel, legal regulation and program planning.

>ECE296 - Issues and Trends

Credits -3 Lecture - 3

This course explores the status of early childhood education. The purpose is to assist students in becoming knowledgeable professionals. Topics may include: inclusion, professionalism, teaching methods, brain research, teenage parents and working parents.

^ED100 - Introduction to Education

Credits -1 Lecture - 1

This course examines teaching as a profession. It provides opportunities for direct experience with, and analysis of, educational settings. Students will explore current issues in education and characteristics of effective schools. Required in Elementary & Secondary AAOT transfer degree, AAS degree for Paraeducators and Paraeducator Certificate.

>ED101 - Introduction to Observation and Experience

Credits -3 Lecture - 2 Lab -1

This course introduces the role and work of instructional assistants and provides information about the Oregon Educational Standards; covers occupational and career development opportunities and provides students direct experience with educational settings and opportunities to examine the attitudes and work habits which influence job effectiveness and satisfaction. Elective in Paraeducator Certificate and AAS degree.

>ED113 - Instructional Strategies in Language Arts

Credits -3 Lecture - 3

Introduces the nature of the reading process and presents a systematic approach to language arts instruction. Students learn to link literacy instruction and assessment to state content standards. Required in Paraeducator Certificate and AAS degree.

>ED114 - Instructional Strategies in Math and Science

Credits -3 Lecture - 3

This course introduces the development of math and science concepts and presents a systematic approach to math and science instruction. Students learn to link math and science instruction and assessment to state content standards. Required in Paraeducator Certificate and AAS degree.

>ED125 - Peer Tutoring/ED 125

Credits - 1 Lecture - 1

This course is designed to prepare and instruct peer tutors on the principles and skills needed to provide effective tutoring services to students enrolled in various classes throughout the community college campus. Student tutors will gain skills and experience needed to assist tutees by participating in both in-class and out of class activities.

>ED130 - Comprehensive Classroom Management

Credits - 3 Lecture - 3

This course provides current theory and methodology for managing small and large groups of students so that students choose to be productively involved in instructional activities. Covers the four major factors or skill areas of effective classroom management; 1) Understanding students' personal/psychological and learning needs, 2) Establishing positive adult-student and student-student relationships, 3) Implementing instructional methods that facilitate optimal learning, and 4) Using organizational and group management methods that maximize positive student behavior and learning. Required in Paraeducator Certificate and AAS degree.

>ED131 - Instructional Strategies

Credits - 3 Lecture - 3

Introduces a variety of teaching techniques and provides practice for students in instructional design. Students plan lessons and teach lessons to small groups of peers or instructional K-12 students and participate in self-evaluation and peer evaluation of others' teaching. Required in Paraeducator Certificate and AAS degree.

>ED169 - Overview of Students with Special Needs

Credits - 3 Lecture - 3

An introduction to the disabling conditions of students with special needs and their implications in school settings. Defines and identifies intervention strategies for disabilities covered under federal law. Required in Paraeducator Certificate and AAS degree.

^ED200 - Foundations of Education

Credits - 3 Lecture - 3

This course provides an overview of the American Education System, including historical, legal, and philosophical foundations. Students will explore the governance of local schools and districts and will consider the roles and ethical obligations of professional educators. Required in Elementary & Secondary AAOT transfer degree, Paraeducator AAS and Certificate degrees

>ED229 - Learning and Development

Credits - 3 Lecture -3

This course addresses current theory regarding human development, intelligence, motivation, and the learning process. Students learn to apply strategies and techniques derived from these theories. Required in Paraeducator Certificate and AAS degree.

>ED235 - Educational Technology

Credits - 3 Lecture -3

This course trains students in the preparation and use of media and technology in school settings. Students will develop an understanding of the role of media in learning and methods for incorporating media in instruction.

>ED254 - Instructional Strategies for English Language Learners

Credits - 3 Lecture -3

This course will examine pedagogical and cultural approaches which lead to successful acquisition of English language skills and content knowledge. Required in Paraeducator Certificate and AAS degree.

>ED258 - Multicultural Education

Credits - 3 Lecture -3

This course covers the philosophy, activities, and techniques appropriate to a culturally sensitive classroom. Students will develop an understanding of the impact of culture on individual perception and learning and group dynamics. Required in Paraeducator Certificate and AAS degree. Will satisfy the Cultural Awareness requirement for the CUESTE program.

>ED266 - Current Issues in Special Education

Credits - 3 Lecture -3

This course is designed to provide students interested in special education an opportunity to explore in more depth current issues in special education. Students will be exposed to current philosophical frameworks, legislative changes, emerging conditions, and technological advances. Elective in Paraeducator Certificate and AAS degree.

>ED268 - Educating Mildly and Severely Handicapped

Credits - 3 Lecture -3

This course covers the theory and techniques of working with handicapped students. Services and funding provided for mildly and severely handicapped students are studied. Elective in Paraeducator Certificate and AAS degree

**Symbols: ^ - Elective + - Lab Science
* - Group Distribution > - C/T Elective**

Course Descriptions

***ED280 - Cooperative Work Experience**

Credits -1-8

The purpose of this education practicum experience is to give first and second year education majors an opportunity to gain volunteer experience with age-appropriate children in an educational setting. Students participating in this practicum must successfully complete a criminal history verification check. Practicum situation may include one-to-one or small group tutoring in reading, math, or other areas in a classroom setting. Required in Elementary and Secondary AAOT transfer degree, AAS and Certificate degrees for paraeducators.

>ED285 - Signing Exact English

Credits -3 Lecture - 3

Beginning communication in Signing Exact English (SEE). This course introduces Manually Coded English sign language systems, focusing specifically on SEE. It includes the theories, rules, principles, and vocabulary of SEE, as well as practice in both receptive and expressive skills. Students will be introduced to the finger spelled alphabet, as well as appropriate body, facial, and dramatic features of sign language. Elective in Paraeducator Certificate and AAS degree.

>ED286 - Signing Exact English

Credits -3 Lecture - 3

This is the second course in a sequence which introduces Manually Coded English sign language systems, focusing specifically on Signing Exact English 2 (SEE). It includes the theory, rules, principles and vocabulary of SEE, as well as practice in both receptive and expressive skills. Students will be introduced to the finger spelled alphabet, as well as appropriate body, facial, and dramatic features of sign language. Elective in Paraeducator Certificate and AAS degree. Prerequisite Ed 285 or instructor approval.

>ED287 - Signing Exact English

Credits -3 Lecture - 3

This course is the third course in a sequence of courses which introduces Manually Coded English sign language systems, focusing specifically on Signing Exact English 2 (SEE). It includes the theory, rules, principles, and vocabulary of SEE, as well as practice in both receptive and expressive skills. Students will be introduced to the finger spelled alphabet, as well as appropriate body, facial, and dramatic features of sign language. Elective in Paraeducator Certificate and AAS degree. Prerequisite Ed 286 or instructor approval.

>ED298 - Special Studies

Credits - 1-3

This course is designed to accommodate a variety of content and subject areas related to education in the K-12 schools. Coursework will be specific to teaching and learning related activities and strategies. These topics may include, but are not limited to, teaching techniques, instructional technology, human relations, communication, and non-instructional support skills. Courses will be taught in a workshop/conference environment in which students choose topics and issues relevant to their specific job responsibilities or are of specific interest to them. Elective in Paraeducator Cert and AAS degree.

***ENG104 - Introduction to Literature**

Credits - 3 Lecture - 3

A course concentrating on the study of fiction through analysis of short stories and/or novels drawn from American, English, Continental, and other literature.

Recommended preparation: WR121

***ENG105 - Introduction to Literature**

Credits - 3 Lecture - 3

A course emphasizing the study and analysis of drama from classical times to the modern period with concentration on the principal types of drama such as comedy and tragedy.

Recommended preparation: WR121

***ENG106 - Introduction to Literature**

Credits - 3 Lecture - 3

A course focusing on the study of poetry, primarily lyric, drawn from American, English, Continental, and other literatures. Elements such as form, texture, and sensuous appeal are explored in close analysis of the poems.

Recommended preparation: WR121

***ENG107 - World Literature**

Credits - 3 Lecture - 3

The first course in a three-part historical introduction to world literature. This course focuses on great works of the ancient world in a variety of forms including: verse, drama, fiction, and non-fiction. Reading and discussion may focus on the literary traditions of the ancient Middle East, Greece, Rome, India, and China.

Recommended preparation: WR121

***ENG108 - World Literature**

Credits - 3 Lecture - 3

The second course in a three-part historical introduction to world literature. This course focuses on medieval and early modern literatures in a variety of forms including: verse, drama, fiction, and non-fiction. Reading and discussion may focus on the literary traditions of Asia, Islam, Africa and Western Europe.

Recommended preparation: WR121

***ENG109 - World Literature**

Credits - 3 Lecture - 3

The last of a three-part historical sequence, this course will explore important literary works of the modern world from the Renaissance to the present. Readings will draw on a range of literatures, which may include Asian, European, Latin American and African. Emphasis will be on cultural diversity, changing literary traditions and the role of literature in the modern world.

Recommended preparation: WR121

***ENG195 - Film as Literature**

Credits - 3 Lecture -3

This course explores film as an art form, fostering visual literacy through close attention to the cinema. Students will study feature films and short films in a variety of genre and styles.

Recommended preparation: WR121

***ENG196 - Film as Literature**

Credits - 3 Lecture -3

This course explores film as an art form, fostering visual literacy through close attention to the cinema. It will concentrate on the art of film making, including cinematography, editing, sound and movement.

Recommended preparation: WR121

***ENG197 - Film as Literature**

Credits - 3 Lecture -3

This course explores film as an art form, fostering visual literacy through close attention to the cinema. It will concentrate on the importance of acting, drama, ideology, theory and literary adaptation to film.

Recommended preparation: WR121

***ENG198 -Special Studies**

Credits - 1-3

This course is designed to provide interested and capable students special topics in English. *Instructor approval required.*

***ENG201 -Shakespeare**

Credits - 3 Lecture -3

A survey of the Elizabethan era and of Shakespeare's dramatic works. Students read early comedies, histories, and tragedies giving special attention to the overall design of each work as well as to its individual beauties.

Recommended preparation: WR121

***ENG202 -Shakespeare**

Credits - 3 Lecture -3

A survey of Shakespeare's middle period. Students read plays of various genres, but class emphasis falls on historical plays with discussion of Shakespeare's developing view of man, society and government.

Recommended preparation: WR121

***ENG203 -Shakespeare**

Credits -3 Lecture - 3

A survey of Shakespeare's later plays including the great tragedies and the romances. Students study both dramatic forms and poetry and discuss the philosophic implications of these major plays.

Recommended preparation: WR121

***ENG204 - Survey of English Literature**

Credits -3 Lecture - 3

This course is a study of the principal works of English literature. Students concentrate on Anglo-Saxon and Medieval literature in the first term and become familiar with literary traditions through reading, lecture, discussion and film.

Recommended preparation: WR121

***ENG205 - Survey of English Literature**

Credits -3 Lecture - 3

The second term of this survey focuses on Renaissance and Eighteenth-Century English literature. Students read and discuss major authors, including Shakespeare, Milton, Swift and Pope.

Recommended preparation: WR121

***ENG206 - Survey of English Literature**

Credits -3 Lecture - 3

The third term of this survey sequence focuses on Modern English Literature. The authors are representative rather than inclusive.

Recommended preparation: WR121

Course Descriptions

***ENG214 - Myth in Oregon Literature**

Credits -3 Lecture - 3

Using Native American stories and stories of the 19th and 20th century immigrants to Oregon as well as contemporary literature of the Northwest, this course is a discussion seminar which explores mythical patterns which emerged from the Northwest landscape along with patterns which Oregonians have imposed upon that landscape.

Recommended preparation: WR121

***ENG240 - Native American Literature**

Credits -3 Lecture - 3

A discussion seminar designed to introduce the student to the emergence of literature being written by members of the first nations of North America, and the connection of that contemporary literature to the oral literature of myth, story, lyric and ritual poetry and oratory.

Recommended preparation: WR121

***ENG253 - Introduction to American Literature**

Credits -3 Lecture - 3

The first of a three-part sequence, this course is a discussion seminar that surveys a multicultural representation of American literary works and major writers from pre-European contact to the Civil War. Or emphasis may be on genre, with the first term focusing on American fiction.

Recommended preparation: WR121

***ENG254 - Survey of American Literature**

Credits - 3 Lecture - 3

The second of a three-part sequence, this course is a discussion seminar that surveys a multicultural representation of American authors and literary works from the Civil War to World War II. Or emphasis may be on genre, with the second term focusing on American drama.

Recommended preparation: WR121

***ENG255 - Survey of American Literature**

Credits - 3 Lecture - 3

The last of a three-part sequence, this course is a discussion seminar that considers a multicultural representation of major American writers and literary works from World War II to the present. Or emphasis may be on genre, with the third term focusing on American poetry.

Recommended preparation: WR121

***ENG260 - Women in Literature**

Credits - 3 Lecture - 3

An examination of writing by women. Students read a variety of fiction and nonfiction forms by women from various places and periods. Genres may include poetry, folksongs, diary and journal entries, fiction and drama, and autobiography.

***ENG263 - Detective Fiction**

Credits - 3 Lecture - 3

Investigation of the detective genre, its historical patterns, and its evolution from Poe to popular contemporary writers. Students will read a variety of detective novels/short stories in the categories of the Armchair/Cerebral Detective and Hard-Boiled Detective.

Recommended preparation: WR121

***ENG264 - Detective Fiction**

Credits - 3 Lecture - 3

Investigation of the detective genre, its historical patterns and its evolution from Poe to popular contemporary writers. Students will read a variety of detective novels/short stories in the category of the Police Detective in America, in England and in Europe.

Recommended preparation: WR121

***ENG275 - Bible as Literature**

Credits - 3 Lecture - 3

A study of this seminal work of Western culture as a great literary achievement, most notably in prose narrative and lyric poetry, emphasizing the characters, plots, themes, symbols and language.

Recommended preparation: WR121

***ENG280 - Cooperative Work Experience**

Credits - 1-8

Provides experience in English classroom for selected English major students who are exploring English teaching.

Recommended preparation: Instructor approval and WR121

***ES211 - Chicano/Latino Historical Experience**

Credits - 3 Lecture -3

Chicano/Hispanic/Latino history in the United States beginning from pre-Columbian times to the present. This course covers pre-Columbian heritage, Spanish colonization, American conquest in the Mexican-American War and the Spanish American War, the Mexicans' role in American labor, Bracero Program, and the Chicano Movement.

***ES212 - Chicano/Latino Political, Economic and Social Issues**

Credits - 3 Lecture -3

Introduces the social, educational, political, and economic status of Latinos in the context of their native countries and United States society, institutions, and structures. Examines demographic profiles and current issues within a Chicano/Latino perspective.

ESS035 - Effective Study Skills III

Credits - 3 Lecture -3

People choosing to take this course are students who want to develop and improve their academic skills. Included are note and test taking, outlining, memorizing techniques and effective text reading. Good reading ability is required for those taking this course.

***FN225 - Nutrition**

Credits - 4 Lecture -4

Nutrition is the study of the nutrients in food and how the body uses them through the life cycle. Food sources, functions and recommendations for the six nutrients are covered. Digestion, absorption and metabolism are discussed. Skills will be developed in evaluation of nutrition information, assessment of dietary intake, recognition of timely national nutrition issues, and an increased awareness of the relationship of diet upon chronic disease. A variety of instructional methods will be selected but emphasis will be upon collaborative learning.

>FN230 - Children, Families and Nutrition

Credits - 3 Lecture -3

This is a course for parents, families, child and health care providers, and early childhood educators. Basic nutrition for the pregnant and breastfeeding woman, the breastfed and bottle-fed infant, and the child will be covered.

Gaining understanding of how eating habits develop and the roles of the child and the parent will be emphasized as well as positive techniques for feeding infants, toddlers and preschooler and dealing with various feeding situations. Nutrition challenges for the child with special health care needs will be included. Resources for planning and preparing nutritious meals will be shared and a toolbox of community nutrition services, menus, recipes and nutrition education activities and materials will be developed by each participant.

***+G101 - Introduction to Geology**

Credits -4 Lecture - 3 Lab -1

A study of the structure and composition of the Earth, minerals, igneous, metamorphic, and sedimentary rocks. Plate tectonics, volcanism, and earthquake activity are interrelated to give an overview of the Earth's dynamic processes. Generally one weekend field trip. Course fulfills laboratory science requirement. Need not be taken in sequence.

***+G102 - Introduction to Geology**

Credits -4 Lecture - 3 Lab -1

This course centers on the dynamic processes that sculpt the surface of Earth: weathering processes, streams, ground water, glaciers, mass movements, wind, and oceans. Topographic maps and aerial photos are also used. Generally one weekend field trip. Course fulfills laboratory science requirement. Need not be taken in sequence.

***+G103 - Introduction to Geology**

Credits -4 Lecture - 3 Lab -1

A study of the early history of Earth and geologic time scale. Sedimentation, sedimentary environment, fossils, and fossilization are discussed along with the stratigraphic history of North America. The beginnings of life are traced through the evolution of plants, vertebrates, and invertebrates. Generally one weekend field trip. Course fulfills laboratory science requirement. Need not be taken in sequence.

***G145 - Geology of the Pacific Northwest**

Credits -3 Lecture - 3

A study of the regional geology of the Pacific Northwest. This course traces the geologic evolution of the Northwest and includes discussion on the history of volcanic activity, fossils, sedimentary environments, and topographic change with time. Field trips to points of interest where appropriate.

***G146 - Rocks and Minerals**

Credits -3 Lecture - 3

An introduction to origin and identification of common rocks and minerals. Topics include crystal forms, physical tests, chemical tests, gem materials, etc. Designed for a rock hound, casual collector, or anyone interested in knowing more about rocks and minerals. Field trips where appropriate.

Course Descriptions

*G147 - Basic Geology

Credits -3 Lecture - 3

An introduction to physical geology, designed to help one become more aware of the processes that shape our geological environment. Topics include rock and mineral formation and identification, volcanoes, earthquakes, plate tectonics, glaciations. Field trips where appropriate.

^G198 - Special Studies

Credits - 1-3

This course is designed to provide interested and capable students special topics in geology. *Instructor approval required.*

*+G201 - Physical Geology

Credits - 4 Lecture - 3 Lab - 1

An in-depth study of the geologic processes occurring on Earth. There are no prerequisites, although a background in science is helpful. Satisfies laboratory science requirements for both science and non-science majors. Topics studied include the origin and identification of rocks and minerals, volcanoes, earthquakes, and plate tectonics. Generally one weekend field trip. Need not be taken in sequence.

*+G202 - Physical Geology

Credits - 4 Lecture - 3 Lab - 1

Topics studied will include evolution of landscapes, stream erosion, glaciations, landslides, and interpretation of topographic maps and aerial photos. There are no prerequisites, although a background in science is helpful. Satisfies laboratory science requirements for both science and non-science majors. Generally one weekend field trip. Need not be taken in sequence.

*+G203 - Historical Geology

Credits - 4 Lecture - 3 Lab - 1

An examination of the evolution of Earth from the standpoint of plate tectonics, including life forms, rock correlation and geologic time. There are no prerequisites, although a background in science is helpful. Satisfies laboratory science requirement for both science and non-science majors. Generally one weekend field trip. Need not be taken in sequence.

>GAM225 - Introduction to Gaming Management

Credits - 4 Lecture - 4

This course will cover an overview of the casino. Topics will include the economics of the casino in addition to its interface with the hotel, organizations, and terminology. This course is not recommended for people who have worked in the gaming industry.

*GEOG101 - Physical Geography

Credits - 3 Lecture - 3

Introduction to physical geography of the earth with specific emphasis on landforms, climate, vegetation, and soils and on the interaction between humans and these elements. This course satisfies science group requirements. *Recommended preparation: WR060*

*GEOG103 - Human Geography

Credits - 3 Lecture - 3

This course introduces students to the discipline of geography and studies patterns of a wide variety of topics including industry and economy, population, tourism, water rights, and politics. The topics are incorporated through the theme of globalization.

Recommended preparation: WR060

*GEOG106 - Human and Cultural Geography

Credits - 3 Lecture - 3

Identifies humankind's occupancy of the earth. Emphasis is on the division of the world into regions, the potential of each region for human use, and humankind's cultural and economic adaptations.

Recommended preparation: WR060

*GEOG107 - Human and Cultural Geography

Credits - 3 Lecture - 3

Describes the characteristics of the economic, urban, and political landscape; how various cultural groups perceive and modify the earth; and the problems they create in so doing.

Recommended preparation: WR060

*GEOG120 - World/Regional Geography

Credits - 3 Lecture - 3

This course studies world patterns of the natural and cultural environments and focuses on the place of each geographic region in the world community.

Recommended preparation: WR060

*GEOG140 - Map Reading and Interpretation

Credits - 3 Lecture - 3

Learning how to use maps for everyday and professional applications. This course covers major types and sources of maps and aerial imagery, how information is simplified and symbolized for presentation on maps, and coordinate and locational systems.

*GEOG206 - Geography of Oregon

Credits - 3 Lecture - 3

A study of the diverse landscapes of Oregon. This course considers natural environment, population growth, and settlements. Special emphasis is placed on the historical geography of selected areas of the state.

Recommended preparation: WR060 and SP111

^GEOG298 - Special Studies

Credits - 1-3

Designed to provide interested and capable students with the opportunity to study special topics in geography.

Recommended preparation: Instructor approval and WR060

*+GS104 -Physical Science/Physics

Credits -4 Lecture - 3 Lab -1

A one-term introduction to the fundamental physical concepts that form the foundation for all of the physical sciences. Topics include measurement, motion, mechanics, and pressure. Course fulfills a laboratory science requirement.

*+GS105 - Physical Science/Chemical Concepts

Credits -4 Lecture - 3 Lab -1

A one-term introduction to chemistry and its application to everyday phenomena. Topics include structure of the atom, chemical bonding, solutions, acids and bases, and chemical reactions. Course fulfills a laboratory science requirement.

*+GS107 - Physical Science/Astronomy

Credits -4 Lecture - 3 Lab -1

A one-term introduction to astronomy that surveys the history of astronomy, our solar system, galaxy, and universe. Topics of current interest to astronomers will be presented. Course includes outdoor observations. Course fulfills a laboratory science requirement.

*+GS110 - Physical Science/Energy

Credits -4 Lecture - 3 Lab -1

Overview of the sources of energy in nature. Emphasis on how energy is coupled to specific principles and processes related to physics and chemistry. Topics include heat, radioactivity, light, sound, and electricity. Course fulfills a laboratory science requirement.

*+GS111 - Physical Science/Forensic Science

Credits -4 Lecture - 3 Lab -1

A one-term introduction to criminalistic theories and practices, including basic techniques of investigation. Topics include fingerprints, blood typing, photography and casting techniques. Course fulfills a laboratory science requirement. No prerequisites, no math requirement.

*+GS142 -Physical Geology/Earth Revealed

Credits -4 Lecture - 3 Lab -1

This online course examines the evolution of planet Earth based upon the dynamics of interacting systems and physical geological attributes of the planet including geologic time, physical phenomena, and weathering. A "field exercise" will be included that will integrate physical geology concepts with a "real world" experience that will be conducted in the community of each individual student. Course fulfills laboratory science requirement.

^GS160 - Observational Astronomy

Credits -3 Lecture - 3

A one-term non-laboratory introduction to astronomy with emphasis on observing the night sky and fundamental astronomical concepts. Course includes outdoor observations.

^GS198 - Special Studies

Credits - 1-3

This seminar course is offered on the basis of demand and covers diverse topics in the natural and physical sciences.

HD080 - Life Transitions

Credits - 2 Other - 2

This course is a five week series of seminars designed for students to develop self-knowledge, coping skills, confidence-building, communication skills, parenting skills, and how to have healthy relationships. Included will be exploration of specific careers and orientation to job-search techniques, learning about college support services, managing resources, networking, exploring nontraditional training options, setting goals, and developing action plans.

Symbols: ^ - Elective + - Lab Science
*** - Group Distribution > - C/T Elective**

Course Descriptions

^HD100 - College Survival and Success

Credits - 3 Lecture - 3

This course teaches students approaches and techniques that will support their success both as individuals and as students in college. Focus is on academic strategies which include note taking, test taking and text reading. Coping skills such as time management, stress management, assertiveness, and methods for organization will also be presented. This class is available as a lecture course and as a distance education course.

^HD109 - Academic Planning

Credits - 1 Lecture - 1

This course covers pathways to gaining a particular certificate or degree from BMCC. Included will be tools to help students determine their learning style and personality type. Students will take career assessments, write goals, and create an academic plan that will facilitate their progress toward the goals. Hindrances to academic progress will also be addressed.

^HD110 - Career Planning

Credits - 2 Lecture - 2

Students gain information about themselves and occupations. They choose two careers and support their choices based upon the information they have acquired. They use interest inventories, computerized exploration programs, and an entrepreneur quiz. They will use the Career Information System to find sources of training and financial aid for the careers they have chosen.

^HD151 - Service Leadership

Credits - 1 Lecture - 1

Designed to provide training in leadership skills for elected student government officers and representatives. Not open to general student enrollment. Course serves as a bridge between community/civic/legislative service and academic experience. Focus is on communication skills, small group dynamics, presentation skills and leadership styles. Repeatable for maximum of 3 credits.

^HD152 - Service Leadership

Credits - 1 Lecture - 1

Designed to provide training in leadership skills for elected student government officers and representatives. Not open to general student enrollment. Course serves as a bridge between community/civic/legislative service and academic experience. Focus is on communication skills, small group dynamics, presentation skills, and leadership styles. Repeatable for maximum of 3 credits.

^HD153 - Service Leadership

Credits - 1 Lecture - 1

Designed to provide training in leadership skills for elected student government officers and representatives. Not open to general student enrollment. Course serves as a bridge between community/civic/legislative service and academic experience. Focus is on communication skills, small group dynamics, presentation skills and leadership styles. Repeatable for maximum of 3 credits.

^HD154 - Ambassadorship

Credits - 1 Lecture - 1

The Student Ambassadors' primary function is to provide leadership, assistance, and information to prospective BMCC students and to assist the College in attracting prospective students. Ambassadors will be responsible for conducting tours, participating in Ambassador training events, visiting high schools, provide office assistance, and other assigned duties. This course covers public speaking, leadership, etiquette, marketing, and college knowledge. This course may be taken up to three times for elective toward a degree.

^HD204 - Self-Motivation and Personal Potential

Credits - 3 Lecture - 3

Students will learn and explore methods for eliminating recurring behavior, feelings or thoughts which can negatively affect the quality of their lives. Subject matter covered will be the psychology of wellness, principles of behavior modification and a holistic approach to an individual's ability to develop a successful self-management plan for living. Focus will be on kinds of life planning, positive health management, assertive communication, social fulfillment and emotional well-being. This course goes beyond acquisition of knowledge or personal awareness. It also includes experiential and collaborative learning in addition to more traditional approaches.

^HD206 - Coping Skills for Stress

Credits - 3 Lecture - 3

The theories and practices of stress management will be presented in this course. Techniques for coping, such as relaxation, visualization, imagery, meditation, exercise, nutrition, rational-emotive thinking, assertion and time management will be employed. Students will be required to assess the impact of various stressors upon their well-being and to design coping styles that are preventative and which promote their mental and physical wellbeing. The focus of this class is educational, not therapeutic. Emphasis will be equally divided among academic and participatory requirements.

^HD254 - Ambassadorship

Credits - 1 Lab - 1

The Student Ambassadors' primary function is to provide leadership, assistance, and information to prospective BMCC students and to assist the College in attracting prospective students. Ambassadors will be responsible for conducting tours, participating in Ambassador training events, visiting high schools, provide office assistance, and other assigned duties. This course expands on the public speaking, leadership, etiquette, marketing, and college knowledge learned in the first year, and includes mentorship of first year students. This course may be taken up to three times for elective toward a degree.

^HE100 - Introduction to Health Services

Credits - 4 Lecture - 3 Lab - 1

Individually designed shadow experiences within the health service professional field that provide the learner the opportunity to apply skills as well as obtain knowledge of various health career occupations. Basic First Aid and CPR are included.

^HE115 - Body Composition Assessment

Credits - 1 Lecture - 1

Percent Body Fat (or lean-to-fat ratio) is a better indicator of health and fitness than scale weight is. This class teaches students about the different methods of assessing percent body fat, their advantages and disadvantages, and how reliable they are. Students will learn to assess lean-to-fat ratio using the skin fold assessment method.

^HE250 - Personal Health

Credits - 3 Lecture - 3

A visionary look at the state of health and health care today. This distance education course offers teachers and learners an up-to-the-minute look at health and health care issues from weight management to cardiovascular disease and from the latest HIV/AIDS treatment to changes in health care delivery systems. Personal Health combines interviews with leading health professionals, dynamic location footage, and illustrative case studies to bring each lesson to life.

^HE252 - First Aid

Credits - 3 Lecture - 3

This course is designed to provide the student with the knowledge and skills necessary in an emergency to call for help, to help keep someone alive, to reduce pain, and to minimize the consequences of injury or sudden illness until professional medical help arrives. Successful completion will lead to an American Red Cross community first aid and community CPR certification.

^HE253 - Personal Nutrition

Credits - 3 Lecture - 3

Orientation to the importance of a diet that is low in saturated fat and cholesterol while high in complex carbohydrates and fiber. Emphasis will be on helping participants choose healthy, low fat foods while still enjoying their diets. The course will include an introduction to nutrients and their uses and food sources, as well as discussion of current topics including weight management, eating disorders, exercise, fad foods and diets, recipe modifications, and reducing risk of disease related to high-fat diet.

^HE261 - Cardio-Pulmonary Resuscitation

Credits - 1 Lecture - 1

Describes principles and procedures of basic life support to victims of airway obstruction, respiratory arrest and/or cardiac arrest. Successful completion leads to an American Red Cross CPR certificate. This course cannot be taken for credit if credit has been given for HE 252.

^HE298 - Special Studies

Credits - 1-3

This course is designed to provide interested and capable students special topics in health. *Instructor approval required.*

>HORT100 - Plant Science

Credits - 3 Lecture - 3

Basic principles of plant science and the environmental factors associated with plant growth and development constitute the core of this course. Agricultural application of plants will be emphasized. Cooperative work experience required.

Corequisite: AGR280

Course Descriptions

>HORT111 - Alternative Crop Production

Credits - 3 Lecture - 3

Explores specialty crop production such as seed, berry, fruit, and melon production. Mulch use and drip irrigation will be emphasized. Greenhouse work may also be included. Cooperative work experience required.
Corequisite: AGR280

^HPE295 - Health and Fitness for Life

Credits - 3 Lecture - 3

Develop an understanding of the interacting influences of physical fitness, nutrition, stress management, and health. Course covers many wellness topics including weight control, eating disorders, diet analysis, methods for behavior change, avoiding destructive habits, cardiovascular health, and maintaining a healthy back.

^HS280 - Cooperative Work Experience

Credits - 1-8

Individually designed internships provide students with the opportunity to apply and learn skills and knowledge in actual human service programs. There is significant variety between sites and individual student objectives. Students will interact with clients and agency staff and will become familiar with policies, procedures, service provision, case management, intervention, and documentation.
Prerequisite: HS170

*HST101 - History of Western Civilization

Credits - 3 Lecture - 3

This course series traces the evolution of human society and thought from the Paleolithic Age to the present. The survey examines the course of western civilization in the ancient Near East, the Mediterranean, and Europe. This course also covers the Paleolithic Age through the rise and fall of the Roman Empire.
Recommended preparation: WR060

*HST102 - History of Western Civilization

Credits - 3 Lecture - 3

This course traces the emergence of a European civilization from the Early Middle Ages to the early 18th century.
Recommended preparation: WR060

*HST103 - History of Western Civilization

Credits - 3 Lecture - 3

This course begins with the Enlightenment and Industrial Revolution and concludes with an examination of the 20th Century West.
Recommended preparation: WR060

*HST104 - World Civilizations I

Credits - 3 Lecture - 3

The first in a series of three World Civilizations courses, the course begins with a study of Near Eastern, Greco-Roman, Indian, and Chinese civilizations; and their basic institutions and divergent tendencies.
Recommended preparation: WR060

*HST105 - World Civilizations

Credits - 3 Lecture - 3

The second in a series of three World Civilizations courses, this course focuses on the impact on other world civilizations of the West's rise to world dominance between 700 and 1700 A.D.
Recommended preparation: WR060

*HST106 - World Civilizations

Credits - 3 Lecture - 3

The third in a series of three World Civilizations courses, the course focuses on the impact of modern Western traditions on the other great world civilizations since the 18th century. The term concludes with an examination of 20th Century developments.
Recommended preparation: WR060

*HST201 - History of the United States

Credits - 3 Lecture - 3

U.S. History traces the growth and development of America from Colonial times to the present society. HST 201 begins with the native peoples of North America and continues through the Age of Jefferson ending c. 1820.
Recommended preparation: WR060

*HST202 - History of the United States

Credits - 3 Lecture - 3

This course begins with expansion and slavery, covers the Civil War and Reconstruction and concludes with the rise of the industrial state and the Progressive Era. The course will cover the period from c. 1815 to 1917.
Recommended preparation: WR060

*HST203 - History of the United States

Credits - 3 Lecture - 3

This course begins with the Progressive Era and covers development through the Twentieth Century to the present.
Recommended preparation: WR060

*HST205 - Women of the West

Credits - 3 Lecture - 3

History of Women in the U.S. (1840s to 1920) examines women's work, stereotypes, social reform activities, family and social relations. Explores class, ethnicity, race and regional diversity using the American West as a framework.
Recommended preparation: WR060

*HST258 - History of Latin America

Credits - 3 Lecture - 3

Surveys the history of economic, political, and social developments in Mexico, Central America, and South America from the first peoples through the Colonial period to the eve of the Wars of Independence.
Recommended preparation: WR060

*HST259 - History of Latin America

Credits - 3 Lecture - 3

Surveys economic, political, religious, and social history in Mexico, Central, and South America from the Wars of Independence through the present.
Recommended preparation: WR060

^HST298 - Special Studies

Credits - 1-3

Specialized courses which may be offered periodically depending on demand and availability.
Recommended preparation: WR060

>HTM100 - Introduction To Hospitality Industry

Credits - 3 Lecture - 3

Introduces the hospitality industry as a single, interrelated industry composed of food and beverage, travel and tourism, lodging, meeting and planning events, recreation and leisure, recreational entertainment, and eco and heritage tourism.

>HTM101 - Customer Service Management

Credits - 3 Lecture - 3

This course provides an in-depth study of the methods and techniques employed by the hospitality and tourism industry to accomplish effective and efficient customer service operation. Includes combined discussions of management theory, systems, decision-making, and leadership directly relevant to any profession with emphasis on the hospitality industry. Also covers the business facets of human resource management, finance, ethics, and total quality management with a business environment.

>HTM102 - Hotel, Restaurant and Travel Law

Credits - 3 Lecture - 3

A comprehensive course of study designed to inform and educate students with the legal aspects of the hospitality and tourism industry. Utilizes critical thinking skills to teach students to communicate with their attorneys, to recognize the ramifications of the policies and practices of their businesses, and to apply practical principles to everyday operations. Students will discuss the recent legal situations and the reasoning of the course taken. Discussions will also be held on the Disabilities Act, sexual discrimination, and civil rights issues. Other discussions include basic court procedures, contract law negligence, guest relationship obligations, alcohol liability, travel agent relationships, licensing, and regulations.

>HTM103 - Marketing in the Hospitality Industry

Credits - 3 Lecture - 3

This course studies how marketing activities direct the flow of goods and services from product to consumer in the hospitality and tourism industry.

>HTM104 - Travel and Tourism Industry

Credits - 3 Lecture - 3

This course explores the major concepts in tourism; what makes tourism possible; and how tourism can become an important factor in the economics of any nation, region, state, or local area. Discusses the fundamentals of the tourism system and the key costs and benefits of a tourism economy. Promotes understanding and knowledge of the diverse elements that constitute the travel and tourism industry and the factors that influence growth and development. Examples of tourism development practices in Oregon will be addressed.

>HTM105 - Introduction to the Food and Beverage Industry

Credits - 3 Lecture - 3

This course covers the food service industry structure, organization, size, economic impact, regulatory industries, and peripheral industries; managerial problems and practices; and trade journals and resources. Reviews food service segments, and current industry operational topics.

Symbols: ^ - Elective	+ - Lab Science
* - Group Distribution	> - C/T Elective

Course Descriptions

>HTM107 - Food Sanitation and Cost Control

Credits - 3 Lecture - 3

This course covers principles and practices of sanitation and safety for managers. Students will discuss Hazard Analysis Critical Control Point (HACCP) system. Covers potable water systems, waste treatment, lodging facilities, recreational facilities, swimming pool and spa regulations, and hazardous materials.

>HTM109 - Introduction to the Lodging Industry

Credits - 3 Lecture - 3

This course introduces the lodging industry, including its structure, size, scope, managerial problems, and practices. Covers the structure and organization within the individual firm's front-office procedures. This course will also explore career opportunities.

>HTM112 - Bed and Breakfast Management

Credits - 3 Lecture - 3

This is an overview course designed to explore the subject of the bed and breakfast and inn keeping industry. Course discusses the realities of purchasing, owning, and operating a successful inn. Topics will explore design, financing, operations, food service/sanitation, marketing, and governmental regulations.

>HTM124 - Catering and Banquet Operations

Credits - 3 Lecture - 3

This course will study on-premise catering facilities, including operations, sales, and relationships with outside vendors and related departments and industries. Emphasizes logistical operations and seeking and servicing various market segments.

>HTM126 - Meeting and Convention Management

Credits - 3 Lecture - 3

Focuses on the management and operations of the meeting, convention, and event market of the hospitality and tourism industry. Introduces the meetings industry, promotional activities, and negotiations for meeting services. Covers convention market salesmanship, customer service, and convention servicing. Incorporates facilities, technology, and media components.

>HTM127 - Travel Sales and E-Commerce

Credits - 3 Lecture - 3

This course prepares travel and tourism students for a successful career in selling travel. It creates an understanding of the broader sales environment. Applies concepts and techniques to sample sales dialogues, examples, and case studies. Assesses the impact of the Internet and e-commerce trends on the travel industry, how consumers currently use the Internet to make travel purchases, and the functionality of travel e-commerce sites. Focuses on how e-commerce travel sites integrate with global distribution systems and the changing value chain in the travel marketplace.

>HTM130 - Beverage Management

Credits - 3 Lecture - 3

This course focuses on cost control, inventory management, and pricing systems required for restaurant and food service operations. It discusses customer demographics shifts, and beverage trends and the importance of responsible alcohol beverage service. It covers wine and beer appreciation, including regional differences, production methods, and upscale product features of distillates. It incorporates beverage mixology, marketing, and profit management.

>HTM132 - Menu Planning

Credits - 3 Lecture - 3

This course covers principles of planning a menu, from concept development and design mechanics to menu pricing and marketing issues. Addresses current food service industry needs, including operations, sanitation, and nutrition concerns; design mechanics; and increasing sales through the menu.

LA025 - Language Arts

Credits - 4 Lecture - 4

This course covers basic reading, writing, spelling, and vocabulary skills needed to prepare students for higher level language arts courses. Reading skills will focus on increasing critical thinking and analysis skills as well as increasing vocabulary fluency and recognition. Writing skills will focus on improving grammar, spelling, punctuation, sentence structure, and paragraph and essay development and organization.

LA035 - Language Arts

Credits - 4 Lecture - 4

This course covers skills needed in reading, writing, and vocabulary to be successful in higher level college courses such as Writing 60 and Writing 121. Reading skills will focus on critical thinking, effective analysis, and the understanding and use of advanced vocabulary. Writing skills will focus on developing paragraphs and essays with emphasis on appropriate grammatical use, essay structure, styles of writing, and conducting research.

^MS101 - Introduction to Leadership and Personal Development

Credits - 2 Lecture - 2

MS101 introduces students to the personal challenges and competencies that are critical for effective leadership. They will learn how the personal development of life skills such as goal setting, time management, physical fitness, and stress management relate to leadership.

MTH025 - Pre-Algebra

Credits - 4 Lecture - 4

This course is designed for students who are almost ready for elementary algebra. Those who place in this course study all processes of fractions, decimals, ratio/proportion/percent, measurement, integers, basic geometry and algebraic expressions and equations. This course is offered in a traditional classroom setting and as a distance education course.
Prerequisite: MTH015 or placement

MTH042 - Technical Mathematics

Credits - 4 Lecture - 3 Other - 1

The student will study and demonstrate knowledge of ratios, proportions, percentages, and application of Elementary Algebra, Elementary Geometry, Elementary Trigonometry, and mathematical formulas to technical problems.

MTH060 - Elementary Algebra

Credits - 4 Lecture - 4

The student will demonstrate knowledge of basic algebra notation, linear equations and inequalities, graphing, linear systems, exponents, and polynomials.

Prerequisite: MTH025 with a C or better or placement

MTH065 - Elementary Algebra

Credits - 4 Lecture - 4

The student will study and demonstrate knowledge of polynomials, factoring, rational expressions and equations, functions and graphs, and additional related topics.

Prerequisite: MTH060 or MTH070A with a C or better or placement

MTH070 - Intensive Elementary Algebra

Credits - 5 Lecture - 5

This course is an intensive review of topics in elementary algebra designed to provide the student with the prerequisite knowledge necessary for success in MTH 095. This course is for the student who has had some experience with algebra. In this course the student will learn to solve a variety of problems including linear equations and inequalities and quadratic equations. Methods will include the use of data tables, graphs and symbolic representation. Students will also be expected to give verbal justification for mathematical models and solution methods. This class is an accelerated version of MTH060 and MTH065. MTH070A covers material from MTH060 and MTH070B cover material from MTH065.

Prerequisite: MTH025 with a C or better or placement

MTH095 - Intermediate Algebra

Credits - 4 Lecture - 4

The student will study and demonstrate knowledge of prerequisite skills needed for MTH 105 and MTH 111. These skills include solving algebraic equalities and inequalities, logarithmic equations, and systems of linear and nonlinear equations. Also included are graphing algebraic functions, logarithmic functions, and conic sections. Emphasis is placed on algebraic problem-solving skills; a graphing calculator will be used as a tool to further algebraic knowledge.
Prerequisite: MTH065 or MTH070B with a C or better or placement

^MTH103 - Problem Solving with Technology

Credits - 1 Lab - 1

A mathematics problem solving course that applies prerequisite algebra skills. Students practice critical thinking skills in a variety of algebraic areas. The main focus of this course is exploration of algebra through the use of technology, i.e., graphics calculators and/or computer software. Offered periodically.
Prerequisite: MTH095 or instructor approval

Course Descriptions

*MTH105 - Introduction to Contemporary Mathematics

Credits -4 Lecture -4

This is a mathematics problem-solving course that applies prerequisite algebra skills. Students practice critical thinking skills in a variety of application areas chosen from the physical and social sciences, modeling, consumer math, statistics, geometry, number theory, logic, probability, and recreational math. The course stresses clear communication, problem solving strategies, group problem-solving experiences, and appropriate use of graphics calculator and computer software as problem-solving tools.

Prerequisite: MTH095 with a C or better or placement

*MTH111 - College Algebra

Credits -4 Lecture -4

Students will demonstrate knowledge of functions in general, polynomial, rational, exponential, and logarithmic functions in particular. Students will also demonstrate knowledge of linear systems, sequences, and series; mathematical induction; and binomial expansion. Emphasis is placed on algebraic problem-solving skills; a graphing calculator will be used as a tool to further algebraic knowledge.

Prerequisite: MTH095 with a C or better or placement

*MTH112 - Elementary Functions

Credits -4 Lecture -4

The students will study and demonstrate knowledge of trigonometric functions, applications of trigonometry, trigonometric identities and equations, complex trigonometric numbers, linear programming, partial fractions, probability and data analysis, conic sections, parametric equations, polar coordinates, and vectors.

Prerequisite: MTH111 with a C or better or placement

^MTH198 - Special Studies

Credits -1-3

This course is designed to provide interested and capable students special topics in mathematics.

Instructor approval needed.

*MTH211 - Foundations of Elementary Mathematics

Credits -4 Lecture -4

The student will study and demonstrate knowledge of problem-solving, sets, relations, whole numbers, numeration systems, and number theory.

Prerequisite: MTH095 with a C or better or placement

*MTH212 - Foundations of Elementary Mathematics

Credits -4 Lecture -4

The student will study and demonstrate knowledge of integers, rational numbers, real numbers, and mathematical systems.

Prerequisite: MTH211 with a C or better or placement

*MTH213 - Foundations of Elementary Mathematics

Credits -4 Lecture -4

The student will study and demonstrate knowledge of geometry, probability, and statistics and other topics in elementary mathematics.

Prerequisite: MTH212 with a C or better or placement

*MTH231 - Discrete Mathematics

Credits -4 Lecture -4

Students will study and demonstrate knowledge of topics chosen from logic, set theory, functions, algorithms, number theory, matrices, proof techniques, recursion, counting techniques, relations, and graphing theory. Offered periodically.

Prerequisite: MTH111 with a C or better or placement

*MTH241 - Calculus for Management/Social Science

Credits -4 Lecture -4

Students will study and demonstrate knowledge of the basic concepts of differential and integral calculus with emphasis on the basic techniques and applications. The approach will be from an intuitive point of view.

Prerequisite: MTH111 with a C or better or placement

*MTH243 - Introduction to Probability and Statistics

Credits -4 Lecture -4

Students will demonstrate knowledge of graphical and numerical descriptive statistics, probability theory, probability distributions, statistical inference, and regression. The emphasis will be on statistical inference making and on interpretation of results of statistical tests. A graphing calculator will be used as an aid to data description and statistical inference.

Prerequisite: MTH111 with a C or better or placement

*MTH251 - Calculus

Credits -4 Lecture -4

Students will study and demonstrate knowledge of limits, continuity, the derivative, and applications, including trigonometry.

Prerequisite: MTH112 with a C or better or placement

*MTH252 - Calculus

Credits -4 Lecture -4

The student will study and demonstrate knowledge and application of the definite integral, differentiation and integration of logarithmic, exponential, trigonometric, and inverse functions and applications.

Prerequisite: MTH251 with a C or better or placement

*MTH253 - Foundations of Elementary Mathematics

Credits -4 Lecture -4

The student will study and demonstrate knowledge of integers, rational numbers, real numbers, and mathematical systems.

Prerequisite: MTH252 with a C or better or placement

*MTH254 -Vector Calculus

Credits -4 Lecture -4

The student will study and demonstrate knowledge of vector-valued functions, functions of several variables, partial differentiation and related applications, and multiple integration with related applications. Offered periodically.

Prerequisite: MTH252

*MTH256 - Differential Equations

Credits -4 Lecture -4

This course covers the methods of solving ordinary differential equations and includes three types of solutions: elementary methods, convergent power series, and numerical methods, with applications to physical and engineering science. Offered periodically.

Prerequisite: MTH252

*MTH261 -Linear Algebra

Credits -4 Lecture -4

Students will study and demonstrate knowledge of matrix solutions to systems of linear equations, determinants, vector spaces, GramSchmidt orthogonalizations, linear transformations, Eigen values and Eigen vectors. Offered periodically.

Prerequisite: MTH252 with a C or better or placement

^MTH280 - Cooperative Work Experience

Credits -1-8

Provides a supervised work experience in mathematics which supplements the "school experience", that is not possible in a normal academic classroom environment.

Instructor approval required.

^MTH298 -Special Studies

Credits -1-3

This course is designed to provide interested and capable students special topics in mathematics. It will provide statistics students an opportunity to use the statistical tools learned in the classroom to analyze real data. This course is a co-requisite with MTH 243.

Instructor approval required.

^MUP105 - Jazz Ensemble

Credits -1 Lab -1

Provides an opportunity for students to rehearse and perform current jazz and jazz standard literature. Course is repeatable up to 3 times (3 credits total).

^MUP115 - General Ensemble

Credits -1 Lab -1

Provides an opportunity for students to rehearse and perform in a select small ensemble. Course is repeatable up to 3 times (3 credits total).

Instructor approval required.

^MUP122 - Concert Choir

Credits -1 Lab -1

Provides the skilled vocalist an opportunity to participate in a select group. Course is repeatable up to 3 times (3 credits total).

Instructor approval required.

Symbols: ^ - Elective	+ - Lab Science
* - Group Distribution	> - C/T Elective

Course Descriptions

^MUP125 - Vocal Jazz Ensemble

Credits - 1 Lab - 1

This opportunity for advanced vocalists to perform literature of the popular and/or vocal jazz styles. Course is repeatable up to 3 times (3 credits total).

Instructor approval required.

^MUP141 - Symphony Orchestra

Credits - 1 Lab - 1

This course provides an opportunity to participate in the Oregon East Symphony, offering performances of a wide variety of orchestral styles. Course is repeatable up to 3 times (3 credits total).

Prerequisite: three quarters of MUP141.

^MUP168 - Applied Woodwinds

Credits -1 Lecture - 1

Individual private instruction is given in technical and stylistic aspects of artistic solo performance. Students enroll for a one-half hour lesson each week in their major instrument each term. Course is repeatable up to 3 times (3 credits total).

^MUP169 - Applied Brass

Credits -1 Lecture - 1

Individual private instruction is given in technical and stylistic aspects of artistic solo performance. Students enroll for a one-half hour lesson each week in their major instrument each term. Course is repeatable up to 3 times (3 credits total).

Instructor approval required.

^MUP170 - Applied Strings

Credits -1 Lecture - 1

Individual private instruction is given in technical and stylistic aspects of artistic solo performance. Students enroll for a one-half hour lesson each week in their major instrument each term. Course is repeatable up to 3 times (3 credits total).

^MUP171 - Applied Piano

Credits -1 Lecture - 1

Individual private instruction is given in technical and stylistic aspects of artistic solo performance. Students enroll for a one-half hour lesson each week in their major instrument each term. Course is repeatable up to 3 times (3 credits total).

^MUP173 - Applied Organ

Credits - 1 Lecture - 1

Individual private instruction is given in technical and stylistic aspects of artistic solo performance. Students enroll for a one-half hour lesson each week in their major instrument each term. Course is repeatable up to 3 times (3 credits total).

^MUP174 - Applied Voice

Credits - 1 Lecture - 1

Individual private instruction is given in technical and stylistic aspects of artistic solo performance. Students enroll for a one-half hour lesson each week in their major instrument each term. Course is repeatable up to 3 times (3 credits total).

^MUP191 - Applied Percussion

Credits - 1 Lecture - 1

Individual private instruction is given in technical and stylistic aspects of artistic solo performance. Students enroll for a one-half hour lesson each week in their major instrument each term. Course is repeatable up to 3 times (3 credits total).

^MUP205 - Jazz Ensemble

Credits - 1 Lab - 1

Provides an opportunity for students to rehearse and perform current jazz and jazz standard literature. Course is repeatable up to 3 times (3 credits total).

^MUP215 - General Ensemble

Credits - 1 Lab - 1

Provides an opportunity for students to rehearse and perform in a select small ensemble. Course is repeatable up to 3 times (3 credits total).

^MUP222 - Concert Choir

Credits - 1 Lab - 1

To provide the skilled vocalist an opportunity to participate in a select group. Course is repeatable up to 3 times (3 credits total).

^MUP225 - Vocal Jazz Ensemble

Credits - 1 Lab - 1

An opportunity for advanced vocalists to perform literature of the popular and/or vocal jazz styles. Course is repeatable up to 3 times (3 credits total).

Prerequisite: MUP125 and instructor approval

^MUP241 - Symphony Orchestra

Credits - 1 Lab - 1

This course provides an opportunity to participate in the Oregon East Symphony, offering performance of a wide variety of orchestral styles. Course is repeatable up to 3 times (3 credits total).

^MUP268 - Applied Woodwinds

Credits - 1 Lecture -1

Individual private instruction is given in technical and stylistic aspects of artistic solo performance. Students enroll for a one-half hour lesson each week in their major instrument each term. Course is repeatable up to 3 times (3 credits total).

Prerequisite: MUP168

^MUP269 - Applied Brass

Credits - 1 Lecture -1

Individual private instruction is given in technical and stylistic aspects of artistic solo performance. Students enroll for a one-half hour lesson each week in their major instrument each term. Course is repeatable up to 3 times (3 credits total).

^MUP270 - Applied Strings

Credits - 1 Lecture -1

Individual private instruction is given in technical and stylistic aspects of artistic solo performance. Students enroll for a one-half hour lesson each week in their major instrument each term. Course is repeatable up to 3 times (3 credits total).

^MUP271 - Applied Piano

Credits - 1 Lecture -1

Individual private instruction is given in technical and stylistic aspects of artistic solo performance. Students enroll for a one-half hour lesson each week in their major instrument each term. Course is repeatable up to 3 times (3 credits total).

Prerequisite: MUP171

^MUP273 - Applied Organ

Credits - 1 Lecture -1

Individual private instruction is given in technical and stylistic aspects of artistic solo performance. Students enroll for a one-half hour lesson each week in their major instrument each term. Course is repeatable up to 3 times (3 credits total).

^MUP274 - Applied Voice

Credits - 1 Lecture -1

Individual private instruction is given in technical and stylistic aspects of artistic solo performance. Students enroll for a one-half hour lesson each week in their major instrument each term. Course is repeatable up to 3 times (3 credits total).

^MUP291 - Applied Percussion

Credits - 1 Lecture -1

Individual private instruction is given in technical and stylistic aspects of artistic solo performance. Students enroll for a one-half hour lesson each week in their major instrument each term. Course is repeatable up to 3 times (3 credits total).

^MUS101 - Fundamentals of Music

Credits -2 Lecture - 2

Elementary study of terms and notation symbols designed to develop elementary competence in performing from notation and in notating musical ideas.

***MUS105 - Music Appreciation**

Credits -3 Lecture - 3

A general survey of music in the Western European Art Music tradition. Music will be discussed with regard to historical events, trends, introduction and development of forms and major composers of each era.

^MUS107 - Studio Recording Techniques

Credits -2 Lecture - 2

A hands on course for training in the use of recording and sound reinforcement equipment. This includes the use and care of microphones, effect units, multitrack recorders and soundboards.

^MUS108 - Studio Recording Techniques

Credits -2 Lecture - 2

A hands on course for training in the use of recording and sound reinforcement equipment. This includes the use and care of microphones, effect units, multitrack recorders and soundboards. A continuation of MUS 107.

Prerequisite: MUS107

Symbols: ^ - Elective + - Lab Science
* - Group Distribution > - C/T Elective

Course Descriptions

***MUS109 - Studio Recording Techniques**

Credits -2 Lecture - 2

A hands on course for training in the use of recording and sound reinforcement equipment. This includes the use and care of microphones, effect units, multitrack recorders and soundboards. A continuation of MUS 108.
Prerequisite: MUS108

***MUS111 - Music Theory**

Credits -4 Lecture - 4

Thorough groundwork in the fundamentals of music, melody, harmony, rhythm, and ear training. Students having a limited piano background should take MUS 131 Class Piano to have an understanding of the keyboard.
Corequisite: MUS114

***MUS112 - Music Theory**

Credits -4 Lecture - 4

Thorough groundwork in the fundamentals of music, melody, harmony, rhythm, and ear training. A continuation of MUS 111.
Prerequisite: MUS111
Corequisite: MUS115

***MUS113 - Music Theory**

Credits - 4 Lecture - 4

Thorough groundwork in the fundamentals of music, melody, harmony, rhythm, and ear training. A continuation of MUS 112.
Prerequisite: MUS112
Corequisite: MUS116

***MUS114 - Ear Training and Sight Singing**

Credits - 1 Lecture - 1

This course offers practice in singing, dictating, and reading music without accompaniment. It stresses music terminology, rhythms, and intervals.
Corequisite: MUS111

***MUS115 - Ear Training and Sight Singing**

Credits - 1 Lecture - 1

This course offers practice in singing, dictating, and reading music without accompaniment. It stresses music terminology, rhythms, and intervals. A continuation of MUS 114.
Prerequisite: MUS114
Corequisite: MUS112

***MUS116 - Ear Training and Sight Singing**

Credits - 1 Lecture - 1

This course offers practice in singing, dictating, and reading music without accompaniment. It stresses music terminology, rhythms, and intervals. A continuation of MUS 115.
Prerequisite: MUS115
Corequisite: MUS113

***MUS131 - Class Piano**

Credits - 2 Lecture - 2

Classroom instruction in piano technique to fit the needs of beginners.

***MUS132 - Class Piano**

Credits - 2 Lecture - 2

Classroom instruction in piano technique to fit the needs of beginners. This is a continuation of MUS 131.
Prerequisite: MUS131

***MUS133 - Class Piano**

Credits - 2 Lecture - 2

Classroom instruction in piano technique to fit the needs of beginners. This is a continuation of MUS 132.
Prerequisite: MUS132

***MUS135 - Class Voice**

Credits - 2 Lecture - 2

For beginners in vocal music. Deals primarily with development of breath control, tone production, articulation and enunciation in a group situation. Classroom performance of song and study of song literature.

***MUS198 - Special Studies**

Credits - 1-3

Three terms of different study in music may be repeated for credit.

***MUS201 - Introduction to Music and Its Literature**

Credits - 3 Lecture -3

Enjoyment and understanding of music through listening and study of its elements, forms, and historical styles from its origins through 1750.

***MUS202 - Introduction to Music and Its Literature**

Credits - 3 Lecture -3

Enjoyment and understanding of music through listening and study of its elements, forms, and historical styles. Music and composers from 1750 to 1850.

***MUS203 - Introduction to Music and Its Literature**

Credits - 3 Lecture -3

Enjoyment and understanding of music through listening and study of its elements, forms, and historical styles. Music and composers from 1850 to the present.

***MUS205 - Introduction to Jazz History**

Credits - 3 Lecture -3

This course will chronologically survey prominent jazz styles and musicians of the 20th century. Listening will be a large part of the coursework.

***MUS206 - Introduction to History of Rock Music**

Credits - 3 Lecture -3

A general survey of the history of rock and roll music. Beginning with its roots in African-American folk blues, this course will follow sociopolitical events that shaped the development of this popular genre. Also to be discussed will be typical instrumental groups, history of electronic amplification of string and keyboard instruments, development of form and lyric content, as well as marketing trends that shape content and intention of rock.

***MUS207 - History of Folk Music**

Credits - 3 Lecture -3

A survey of Anglo-American folk music and its subsequent styles from the first collected folk songs of Cecil Sharp (around 1900) to the present. Beginning with the Appalachian instrumental and vocal traditions, later folk-based styles will be discussed including country music, folk protest, bluegrass, folk rock, and progressive folk. Also to be discussed will be characteristics of the Anglo-American style with musical retentions from British Isles.

***MUS211 - Music Theory**

Credits -3 Lecture - 3

Continues studies on the elements of music, with emphasis upon analysis of various musical styles and trends.
Prerequisite: MUS111, 112, 113 with a grade of C or better.

***MUS212 - Music Theory**

Credits -3 Lecture - 3

Continues studies on the elements of music, with emphasis upon analysis of various musical styles and trends. A continuation of MUS 211.
Prerequisite: MUS111, 112, 113 and MUS211

***MUS213 - Music Theory**

Credits -3 Lecture - 3

Continues studies on the elements of music, with emphasis upon analysis of various musical styles and trends. A continuation of MUS 212.
Prerequisite: MUS111, 112, 113 and MUS211, 212

***MUS298 - Special Studies**

Credits -1-3

Selected topics in music including pedagogy, conducting and performance practice.

>NUR101 - Fundamentals of Nursing

Credits -9 Lecture - 5 Lab -1 Other - 3

This course presents concepts of nursing and how they relate to human beings in modern society. Explored are the rules and responsibilities of nurses, legal aspects, the health team members, and the goal of the health care delivery system. The student is introduced to the concepts of the health-illness continuum as it relates to human beings throughout the life cycle, the basic needs of human beings, the nursing process, and fundamental skills in patient care. Opportunities are provided for skills practice in simulated laboratory and clinical settings. The student is also introduced to beginning psychiatric concepts of stress and adaptation, crisis theory, therapeutic communication and the sick role.
Admission in the nursing program required

>NUR102 - Medical-Surgical Nursing

Credits - 9 Lecture - 5 Other -4

Content includes concepts and skills of holistic medical-surgical nursing throughout the life span, including pediatric, adult and geriatric nursing. With faculty guidance, the student will apply and utilize concepts learned in NUR 101 to develop skills needed for effective nursing practice with children, adults and the aged. Special emphasis is placed on the care of the patient experiencing diagnostic procedures and tests, surgical interventions and disturbances in fluid and electrolyte balance. In addition, the care of the patient in shock, experiencing hemorrhage, blood transfusions and transplants are also discussed. The care of the patient and their family will be an integral part of the curriculum for each age group. This course continues to develop and reinforce medication calculations and administration as it applies to the health care setting.

Prerequisite: NUR101 and NUR254,

Course Descriptions

>NUR103 - Medical-Surgical Nursing

Credits - 13 Lecture - 9 Other - 4

Classroom instruction presents concepts, disease processes by system, adaptation to illness, and development of skills in medical-surgical nursing of children, adults and the aged. The student will further develop and apply concepts learned in NUR 102. Supervised experiences are provided in applying principles of nursing and related disciplines to meet the basic needs of these groups in various clinical settings. This course integrates the application of medication calculation and administration.

Prerequisite: NUR102, PHC211 and NUR151

>NUR151 - Nursing Skills Lab

Credits - 1 Lab - 1

This course applies the nursing process and PN skills in intravenous therapy, enteral nutrition, incident reports, transcribing orders, tracheostomy management, suctioning techniques and medication management. Students are provided opportunities for skills practice and return demonstration with mastery of skills in a simulated laboratory.

Prerequisite: NUR101 and NUR254

>NUR161 - Nursing Skills Lab

Credits - 1 Lab - 1

This course applies the nursing process and advanced skills in intravenous therapy, central venous catheters, vascular access devices, blood transfusions, total parenteral nutrition, task delegation and assignment, and critical thinking application. Students are provided opportunities for skills practice and return demonstration with mastery of skills in a simulated laboratory.

Prerequisite: NUR103

>NUR171 - Nursing Skills Lab

Credits - 1 Lab - 1

Application of advanced nursing skills in respiratory/mock code, application of critical thinking and ethical/legal responsibilities in job skills competencies, prioritization/analysis of RN level care of patients. Students are provided opportunities for skills practice and return demonstration with mastery of skills in a simulated laboratory.

Prerequisite: NUR161 and NUR203

>NUR201 - Advanced Medical-Surgical Nursing

Credits - 11 Lecture - 6 Other -5

The holistic study of acute and chronic disorders as related to adult and pediatric nursing practice. Advanced medical-surgical nursing concepts and skills are applied to the care of adults and children in ambulatory care settings. Clinical practice focuses on the integration of this course with prerequisite concurrently acquired knowledge from nursing and support courses. Critical thinking is reinforced along with assessment skills and medication administration in clinical settings. Nursing process, legal/ethical issues, current trends in health care, and case management concepts are continually applied to prepare for the role of the registered nurse.

Prerequisite: NUR171, NUR202

>NUR202 - Maternal, Neonatal and Women's Health

Credits - 11 Lecture - 6 Other -5

This course examines maternity and women's health care, and cultural, physiologic, and psychosocial needs during the reproductive and childbearing cycle. Case management, which may incorporate the nursing process and collaborative care, is stressed as well as promotion of wellness throughout a woman's lifespan. Content includes the normal process of childbearing, an introduction to high-risk conditions, and selected common gynecological conditions, and medical surgical concepts.

Prerequisite: NUR203, NUR161

>NUR203 - Psychiatric and Community Nursing

Credits - 11 Lecture - 6 Lab -5

The study of psychiatric and community concepts, principles, and psychopharmacology and psychobiology as related to the psychiatric and community nurses role in the care of children, adolescents, adults, families, and the aged. Content includes major mental and stress-related illnesses, personality disorders, crisis intervention, chemical dependency, losses, functional assessment, and community resources/placements and violence and victimology. These are presented in the framework of prevention, treatment modalities, and rehabilitation. Clinical practice focuses on integration of the therapeutic nurse-patient relationship in selected mental health, and community and medical surgical facilities. Application is made of legal aspects, critical thinking skills, current mental health issues, and nursing process to prepare for psychiatric and community nursing roles.

Prerequisite: NUR103

>NUR254 - Health Assessment

Credits -3 Lecture - 3

This course provides a basic foundation of knowledge and skills involved in the physical and psychosocial assessment of individuals. This course also provides application of skills and nursing knowledge utilized in obtaining a health history and physical assessment of individuals throughout the lifespan in varied clinical settings. Emphasis will be on application of knowledge and skills, which will include a health history and physical assessment utilizing inspection, palpation, percussion, and auscultation.

Admission in the nursing program required

Corequisite: NUR101

>NUR296 - RN Review

Credits -1 Lecture - 1

This class is designed as a self-study course. The focus is an overall review of the content learned in the nursing program with emphasis on test-taking skills to enhance the student's ability to successfully pass the NCLEX.RN.

Prerequisite: NUR254, NUR171, and PHC212

^PE131 - Introduction to Physical Education

Credits -3 Lecture - 3

An introduction to the fields of Health, Physical Education, Recreation and Sports Management includes professional opportunities and required academic qualifications. The course includes a "shadow" experience and information regarding American College of Sports Medicine and American Council on Exercise certifications.

^PE185 - Physical Education Activity

Credits - 1 Other - 1

Program of study and activity in a specific area of physical education to include introduction to rules, principles, guidelines, and techniques of the stated activity. Students will take part in the activity to better learn about it as well as to maintain physical fitness.

^PE198 - Special Studies

Credits - 1-3

Selected studies in health and physical education.

^PE280 - Cooperative Work Experience

Credits - 1-8

An introduction to working in the field of physical education. Students set work objectives with their supervisors and are then graded according to fulfilling those objectives, as well as work habits, attendance, leadership, performance, etc. Work areas include lifeguarding, swimming instruction, P.E. teaching assistance, coaching assistance, and recreational facilities management.

Instructor approval required.

^PE290 - Lifeguard Training Review

Credits - 1 Lab - 1

The purpose of this course is to update student's American Red Cross certification in Lifeguard training (PE 291). Students who possess a current ARC Lifeguard Training certificate are eligible to enroll in this review course. Offered Winter Term Only. Recommended preparation: The student must possess a current ARC Lifeguard Training Certificate

^PE291 - Lifeguard Training

Credits - 3 Other - 3

This course is designed to provide lifeguard candidates and lifeguards with the skills and knowledge necessary to keep the patrons of aquatic facilities safe in and around the water. Successful completion will lead to the American Red Cross lifeguard training certificate. Recommended preparation: The student must possess strong swimming skill proficiency and strength.

^PE292 - Water Safety Instructor/WSI

Credits - 2 Lecture - 1 Other -1

The student will learn how to teach swimming and water safety and further develop personal skills in these areas. Successful completion leads to the American Red Cross Water Safety Instructor (WSI) certificate.

Recommended preparation: Student must be at least 17 years old at the start of course and must pass the pre-course written and skills test.

Symbols: ^ - Elective	+ - Lab Science
* - Group Distribution	> - P/T Elective

Course Descriptions

^PE293 - Lifeguard Instructor Training/LGI
Credits - 2 Lecture - 1 Other - 1
The purpose of this course is to train candidates to teach the American Red Cross Lifeguard Training, Lifeguard Training Review, Community Water Safety, CPR for the professional rescuer and Lifeguarding Instructor Aid courses. Successful completion leads to the American Red Cross Lifeguard Instructor (LGI) certificate. Recommended preparation: Student must be at least 17 years old at the start of course and must pass two pre-course written exams and four skill scenarios. .

>PHC211 - Pharmacology
Credits - 2 Lecture -2
This course is designed to provide the nursing student with background to understand actions of drugs in the human body. It provides the opportunity for the student to develop knowledge of nursing implications related to the administration of specific medication and follow-up care of patients. Included are current concepts of pharmacology and their relationship to patient care. The basic principles of pharmacology, drug actions, indications, contraindications, toxicity, side effects, pharmacodynamics and therapeutic dosage range of some groups of drugs are explored. Application of principles are included in the clinical setting.
Prerequisite: MTH095, NUR101 and NUR254

>PHC212 - Pharmacology
Credits - 2 Lecture -2
This course is designed to provide the nursing student with background to understand actions of drugs in the human body. It provides the opportunity for the student to continue to develop knowledge of nursing implications related to the administration of specific Medications. Medication and follow-up care of patients. Included are current concepts of pharmacology and their relationship to patient care. The drug actions, indications, contraindications, toxicity, side effects, pharmacodynamics and therapeutic range of drugs are explored. Application of principles are included in the clinical setting.
Prerequisite: MTH095, NUR102 and PHC211

***PHL101 - Introduction to Philosophy**
Credits - 3 Lecture -3
Introduces the student to major issues in philosophy, a historical overview and sub-genres of the philosophical tradition. Completion of WR 121 recommended but not required.
Recommended preparation: WR121

***PHL102 - Introduction to Philosophy**
Credits - 3 Lecture -3
Emphasizes significant issues and explores responses to problems posed in the branch of philosophy called ethics. Completion of WR 121 recommended but not required.
Recommended preparation: WR121

***PHL103 - Introduction to Philosophy**
Credits -3 Lecture - 3
Emphasizes critical thinking in the examination of particular philosophical issues and problems. Completion of WR 121 recommended but not required.
Recommended preparation: WR121

***+PHY101 - Essentials of Physics**
Credits -4 Lecture - 3 Lab -1
This problem-solving course deals with vectors, force, motion, energy, and properties of materials. Students will be expected to submit laboratory reports, homework and will take quizzes and examinations. Course fulfills a laboratory science requirement.
Prerequisite: MTH060

^PHY198 - Special Studies
Credits -1-3
This course provides an opportunity for a student to participate in either a seminar or laboratory project outside of the regular class situation. The number of credits is variable and will be arranged by the instructor.
Instructor approval required.

***+PHY201 - General Physics**
Credits -5 Lecture - 4 Lab -1
An introductory laboratory course dealing with mechanics, sound, heat, light, electricity, and modern physics. This course makes extensive use of algebra.
Prerequisite or Corequisite: MTH111

***+PHY202 - General Physics**
Credits -5 Lecture - 4 Lab -1
An introductory laboratory course dealing with mechanics, sound, heat, light, electricity, and modern physics. This course makes extensive use of algebra. A continuation of PH 201.
Prerequisite: PHY201

***+PHY203 - General Physics**
Credits -5 Lecture - 4 Lab -1
An introductory laboratory course dealing with mechanics, sound, heat, light, electricity, and modern physics. This course makes extensive use of algebra. A continuation of PH 202.
Prerequisite: PHY202

***+PHY211 - General Physics with Calculus**
Credits -5 Lecture - 4 Lab -1
An examination of mechanics, sound, heat, light, electricity, and magnetism. This course is recommended for physics majors, engineering majors, and other science students with a calculus background. Course fulfills a laboratory science requirement.
Prerequisite: MTH251

***+PHY212 - General Physics with Calculus**
Credits - 5 Lecture - 4 Lab - 1
An examination of mechanics, sound, heat, light, electricity, and magnetism. This course is recommended for physics majors, engineering majors, and other science students with a calculus background. Course fulfills a laboratory science requirement. A continuation of PH 211.
Prerequisite: PHY211
Corequisite: MTH252

***+PHY213 - General Physics with Calculus**
Credits - 5 Lecture - 4 Lab - 1
An examination of mechanics, sound, heat, light, electricity, and magnetism. This course is recommended for physics majors, engineering majors, and other science students with a calculus background. Course fulfills a laboratory science requirement. A continuation of PH 212. *Prerequisite: PHY212*
Corequisite: MTH253

^PS198 - Special Studies
Credits - 1-3
Designed to provide interested and capable students with the opportunity to study special topics in political science.
Recommended preparation: WR060

***PS201 - American Government and Politics**
Credits - 3 Lecture - 3
This course begins by examining the Constitutional principles of the United States government. Students will learn about the decision making process behind American politics.
Recommended preparation: WR060

***PS202 - American Government and Politics**
Credits - 3 Lecture - 3
This course will provide an overview of American political institutions. Students will study individual rights and liberties. The term concludes with an examination of current national policy issues.
Recommended preparation: WR060

***PS203 - American Government/State and Local**
Credits - 3 Lecture - 3
Examines politics and government in the American states. Emphasis will be on the State of Oregon.
Recommended preparation: WR060

***PS206 - Politics of Western Europe and Russia**
Credits - 3 Lecture -3
This is a comparative politics course examining government and politics in post World War II Western Europe and Russia. Countries to be studied may include: Great Britain, France, Germany, Italy, Russia, the Scandinavian countries and others.
Recommended preparation: WR060

^PS222 - Public Policy
Credits - 3 Lecture -3
The purpose of this course is to impart an understanding of the political system and processes government agency employees find dictating many of their actions.
Recommended preparation: WR060

^PSY101 - Psychology and Human Relations
Credits - 3 Lecture -3
A practical exploration of the psychological concepts and processes which allow people to adjust to their environment. Specific topics include: stress and coping skills, employment relations, communication, human development and methods of psychological understanding. Emphasis is on practical application.
Recommended preparation: WR060

^PSY119 - Process In Living
Credits - 3 Lecture -3
This course surveys the areas of personality development and psychology. Specific topics include: ages and stages of the lifespan, theories of personality, self-awareness, health and stress, and influences on development.
Recommended preparation: WR060

Course Descriptions

^PSY198 - Special Studies

Credits - 1-3

Offers topics of study in psychology with individual research or field study.

Recommended preparation: WR060

***PSY201 - General Psychology**

Credits - 3 Lecture -3

A survey of the basic concepts and principles of psychology. Specific topics include: the nature and research methods of psychology; the biological basis of behavior, sensory, and perceptual processes; states of consciousness; and sleep and dreams. Emphasis is both theoretical and applied.

Recommended preparation: WR060

***PSY202 - General Psychology**

Credits - 3 Lecture -3

Surveys the areas of cognition and emotion. Specific topics include: learning, memory, intelligence, thought, language, motivation and emotion. Emphasis is on both theory and application.

Prerequisite: PSY201

Recommended preparation: WR060

***PSY203 - General Psychology**

Credits -3 Lecture - 3

Surveys the areas of human development, personality, plus clinical and social psychology. Specific topics include: ages and stage of the lifespan, theories of personality, health and stress, abnormal behavior, psychotherapy and social influence.

Prerequisite: PSY201

Recommended preparation: WR060

***PSY231 - Human Sexuality**

Credits -3 Lecture - 3

A survey course involving the study and discussion of the biological, social and psychological aspects of human sexual functioning with emphasis on sexual arousal and response patterns, sexual attitudes and behavior and sexual myths and fallacies.

Prerequisite: PSY201

Recommended preparation: WR060

***PSY237 - Human Development**

Credits -3 Lecture - 3

A life-span examination of change and consistency as people age. Studies the stages of infancy, childhood, adolescence and adulthood as influenced by maturation and socialization. Includes discussion of research strategies and theories of behavior.

Prerequisite: PSY201

Recommended preparation: WR060

^RD120 - Critical Reading and Thinking

Credits -3 Lecture - 3

This course will sharpen students' abilities to think and read clearly, logically, critically, and effectively. Students will develop analytical skills necessary for problem solving and making the best choices in their academic, career, and personal lives. Students regularly interact in group discussions about the thinking and reading process.

>RNG241 - Range Management

Credits -3 Lecture - 2 Lab -1

Plants and domesticated farm animals: the integration of climate, soil, vegetation, and animal factors in the economic management of a range ecosystem.

^SOC198 - Special Studies

Credits -1-3

This course is designed to provide interested and capable students special topics in sociology.

Recommended preparation: WR060

***SOC204 - General Sociology**

Credits - 3 Lecture - 3

This course is a sociological study of social group behavior and social structures, emphasizing diversity and commonalities among groups within society. Topics are examined through the framework of sociological perspectives, encouraging critical thinking and personal responsibility about social issues.

Sociology 204 is the foundational course for all other Sociology offerings.

Recommended preparation: WR060

***SOC205 - General Sociology**

Credits - 3 Lecture - 3

This course is intended to provide introduction to the dynamics of social stratification, social inequalities, collective behavior and social movements. We will examine stratification theories, global stratification, inequalities of class, gender, age and race, privilege and oppression, and collective behavior.

Recommended preparation: WR060

Prerequisite: SOC204 or instructor's approval

***SOC206 - General Sociology/Problems and Issues**

Credits - 3 Lecture - 3

This course is intended to provide an introduction to the following major social institution: family, religion, education, economics, politics, science and the media and the problems and issues existing within each. The focus is on modern American society and the impact of social change on major institutions, but other societies will be explored and used for comparison.

Recommended preparation: WR060 or

instructor's approval

***SOC213 - Minorities**

Credits - 3 Lecture - 3

A survey of minority groups, with special emphasis on local groups in which causes and consequences of minority status are examined. By confronting the pervasive nature of prejudice and discrimination, we will explore the dynamics of institutionalized racism, focusing specifically on race relations within our social institutions. The political, economic, and social lives of several groups - White Ethnic Americans, Native Americans, Asian Americans, Latinos and African Americans.

Recommended preparation: SOC204 and WR060

***SOC217 - Family and Society**

Credits - 3 Lecture - 3

The historical development of the family as an institution, its structure and functions, and changes in contemporary American society. Emphasis is placed on changes that produce societal and individual stress.

Recommended preparation: SOC204 and WR060

^SP100 - Human Communications

Credits - 3 Lecture -3

An introductory course that focuses on the process and functions of communication in interpersonal, small group, interview, mass, and intercultural contexts. Emphasis is placed on helping the student increase his/her competence as a communicator in each of these contexts.

Recommended preparation: WR060

***SP111 - Fundamentals of Speech**

Credits - 3 Lecture -3

Fundamentals of preparation and presentation of oral discourse. Emphasis is on informative speaking, and also in-depth introduction to classical rhetorical concepts of persuasive speaking.

Recommended preparation: WR060

***SP112 - Fundamentals of Speech**

Credits - 3 Lecture -3

Review and continuation of SP 111. Emphasis is on development of skills in group discussions and group problem-solving techniques. Introduction to argumentation.

***SP113 - Fundamentals of Speech**

Credits - 3 Lecture -3

Polishing of skills and techniques. Projects in persuasion, argumentation and debate. Offered depending on demand.

***SP115 - Intercultural Communication**

Credits - 3 Lecture -3

An introductory course that focuses on the impact of culture on the communication process. Emphasis is placed on both understanding cultural diversity and enhancing communication effectiveness in various intercultural contexts.

Recommended preparation: WR060

^SP229 - Oral Interpretation

Credits - 3 Lecture -3

The application of principles of oral reading to literature.

Recommended preparation: WR060

***SP237 - Gender and Communication**

Credits - 3 Lecture -3

This course focuses on the similarities and differences in male and female communication styles and patterns. Particular attention is given to the implications of gender as social construct upon perception, values, stereotypes, language use, nonverbal communication and power and conflict in human relationships. Discusses influences of mass communication upon shaping and constructing male and female sex roles.

Recommended preparation: WR060

Symbols: ^ - Elective + - Lab Science
* - Group Distribution > - C/T Elective

Course Descriptions

^SPAN101 - First Year Spanish

Credits -4 Lecture - 4

Introduction to Spanish, stressing speaking and reading. Exercises in elementary composition and grammar.

^SPAN102 - First Year Spanish

Credits -4 Lecture - 4

A continuation of SPAN 101.
Prerequisite: SPAN101 or instructor approval.

^SPAN103 - First Year Spanish

Credits -4 Lecture - 4

A continuation of SPAN 102.
Prerequisite: SPAN102 or instructor approval

***SPAN201 - Second-Year Spanish**

Credits -4 Lecture - 4

Intensive oral and written exercises designed to help the student acquire an accurate and fluent use of Spanish. Selections from representative authors are studied.
Prerequisite: SPAN103 or instructor approval

***SPAN202 - Second-Year Spanish**

Credits -4 Lecture - 4

A continuation of SPAN 201. Emphasis on advanced use of past tense and on hypothetical and persuasive language. We will also include literary selections.
Prerequisite: SPAN201 or instructor approval

***SPAN203 - Second-Year Spanish**

Credits -4 Lecture - 4

A continuation of SPAN 202. Emphasis on advanced verb moods and application of language.
Prerequisite: SPAN202 or instructor approval

^SPAN211 - Spanish Conversation and Composition

Credits -3 Lecture - 3

Intensive conversation and essay writing of a general character designed to improve oral and written ability in Spanish.
Instructor approval required.

^SPAN212 - Spanish Conversation and Composition

Credits -3 Lecture - 3

A continuation of SPAN 211.
Instructor approval required.

^SPAN213 - Spanish Conversation and Composition

Credits -3 Lecture - 3

A continuation of SPAN 212.
Instructor approval required.

>SUR161 - Plane Surveying

Credits - 5 Lecture - 3 Lab - 2

Principles and practices of leveling, linear and angular measurements, Gaussian Error Theory applied to measurements, care and adjustment of instruments, note-keeping and manual and machine methods of computation, including use of calculators and electronic computers.

>SUR162 - Surveying and Mapping

Credits - 5 Lecture - 3 Lab - 2

Field and office procedures in property surveying and preparation of plats and other maps; State Plane Coordinates, Solar observations, and GPS, legal elements of written and unwritten conveyances.
Prerequisite: SUR161

>SUR166 - Highway Fundamentals

Credits - 3 Lecture - 3

A study of highway surveys, design standards, circular and vertical curves, curve transitions, earthworks and drainage.
Prerequisite: SUR162

>SUR167 - Surveying Seminar

Credits - 3 Lab - 6

A continuation of SUR 166 involving applied surveying techniques in a project oriented environment. Credit hours provide student access to State licensing process.
Prerequisite: SUR166

***TA101 - Introduction to the Theatre**

Credits - 3 Lecture - 3

This course provides an introduction to the world of the theatre by exploring the origins of drama, historical and contemporary styles of playwriting and theatrical performance, the components of a stage production, and the many functions of the artists and craftspeople who collaborate to make theatre happen.
Recommended preparation: LA035

***TA141 - Fundamentals of Acting Techniques**

Credits - 3 Lecture - 2 Lab - 1

This course provides a basic introduction to contemporary acting theories and techniques. Through participation in acting exercises, improvisations, and prepared monologues and scenes, the student will learn fundamental acting terminology and be introduced to a variety of contemporary acting training philosophies.
Recommended preparation: LA035

***TA142 - Fundamentals of Acting Techniques**

Credits - 3 Lecture -2 Lab -1

This course is a continuation of TA 141, however it may be taken without previous acting experience or coursework. It provides a continued exploration of contemporary acting theories and techniques via classroom activities and prepared presentations.
Recommended preparation: LA035

***TA143 - Fundamentals of Acting Techniques**

Credits - 3 Lecture -2 Lab -1

This course is a continuation of TA 142, however it may be taken without previous acting experience or coursework. It provides a continued exploration of contemporary acting theories and techniques via classroom activities and prepared presentations. Activities will include opportunities for public performance.
Recommended preparation: LA035

^TA147 - Voice and Diction for the Theatre

Credits - 3 Lecture -3

This studio course introduces all aspects of vocal production for the stage, including breathing, support, articulation and projection. (Not offered every year.)
Recommended preparation: LA035

^TA165 - Technical Theatre Workshop

Credits - 3 Lab - 3

This course provides the opportunity to explore the various technical components of a theatrical production through hands-on participation in the off-stage activities necessary for the staging of a play. May be repeated for a maximum of 9 credits.

^TA180 - Theatre Rehearsal and Performance

Credits - 3 Lab - 3

This course provides credit for rehearsal and performance of a play. May be repeated for a maximum of 9 credits.

^TA241 - Intermediate Acting Techniques

Credits - 3 Lecture -2 Lab -1

This course is a continuation of TA 141-143, however it may be taken without previous acting experience or coursework. It provides an exploration of advanced contemporary acting theories and techniques via classroom activities and prepared presentations.

^TA242 - Intermediate Acting Techniques

Credits - 3 Lecture -2 Lab -1

This course is a continuation of TA 241, however it may be taken without previous acting experience or coursework. It provides an exploration of advanced contemporary acting theories and techniques via classroom activities and prepared presentations

^TA243 - Intermediate Acting Techniques

Credits -3 Lecture - 2 Lab -1

This course is a continuation of TA 242, however it may be taken without previous acting experience or coursework. It provides an exploration of advanced contemporary acting theories and techniques via classroom activities and prepared presentations. Activities will include opportunities to perform and direct stage productions to be presented to the public.

>WLD111 - Basic Gas and Arc Welding

Credits - 3 Lab - 3

In introduction to welding practices including oxyacetylene welding and cutting, arc welding, welding rod identification and application, properties of metals, joint preparation, and weld faults and identification.

>WLD112 - Advanced Arc Welding

Credits - 3 Lab - 3

An advanced level course for students who know welding safety, basic practices and terminology. Student will learn higher-level practices and improve their skills learned in the basic class.

>WLD221 - TIG Welding

Credits - 3 Lab - 3

Designed for students who have basic level welding skills to introduce Tungsten Arc Welding techniques including the setup of equipment for the welding process.

>WLD253 - Welding Practices for Certification

Credits - 3 Lab - 3

Designed for students who have advanced level arc welding skills to prepare for structural certification. Weld coupons will be tested and documented when they have passed the required weld strength and quality.

Course Descriptions

>WLD256 - Pipe Welding for Certification

Credits - 3 Lab - 3

Designed for students who have advanced level arc welding skills to introduce pipe-welding techniques to prepare for pipe welding certification. Weld coupons will be tested and documented when they have passed the required weld strength and quality.

WR060 - Elements of the Essay

Credits -3 Lecture - 3

Introduces students to the academic essay. The course moves from developing clear, coherent paragraphs to composing and revising the academic essay. Students are encouraged to develop confidence in their writing, strengthen composing and editing skills, collaborate in the writing process, and practice critical thinking.
Prerequisite: LA035 or placement test

WR065 - Introduction to Technical Writing

Credits - 3 Lecture - 3

Introduces students to the basic elements of expository technical writing. Students will move from short, paragraph length technical works to multi-paragraph documents. Additional attention is directed toward integrating graphics into the writing, presenting the material orally and creating job search documents.

Prerequisite: LA035 or placement test

^WR115 - Introduction to College Writing

Credits - 3 Lecture - 3

This course introduces college-level critical inquiry in academic reading and writing. Students will work on developing their ability to read critically and write college-level essays in a variety of different writing contexts and situations. Emphasis is on learning to use the conventions of written language appropriately and skillfully for different purposes and to experience and use writing as a recursive, social, and collaborative process. (Transfer elective from 1998 forward.)

Prerequisite: WR060 with "C" or higher, or placement test

*WR121 - English Composition

Credits - 3 Lecture - 3

The first of a three-course sequence required by the AAOT degree, this course focuses on writing clear, detailed, informative essays in a variety of forms, active reading, and critical thinking. Completion of WR 115 recommended but not required.

Prerequisite: WR115 with "C" or higher, or placement test

*WR122 - English Composition

Credits - 3 Lecture - 3

The second of a three-course sequence, this course focuses on the development of student skills in evaluating and composing essays of various lengths, with emphasis on style of expression, logical thought and evidence, and argumentative approaches and strategies.

Prerequisite: WR121 with "C" or higher

*WR123 - English Composition

Credits - 3 Lecture - 3

A study of current research practices. The student is asked to learn research techniques and to write one or two long papers or several short ones using these skills.

Prerequisite: WR122 with "C" or higher

^WR198 - Special Studies

Credits - 1-3

Designed to provide interested and capable students with the opportunity to study special topics in writing.

*WR227 - Technical Report Writing

Credits - 3 Lecture -3

Researching and reporting technical information including business proposals, business plans, feasibility studies, and process instructions.

Concentration is on using information resources, evaluating and organizing materials, and developing written and oral presentations.

Prerequisite: WR121 with "C" or higher

*WR241 - Introduction to Imaginative Writing

Credits - 3 Lecture -3

A course in creative writing designed for those who wish to express themselves in fiction, nonfiction, drama, poetry, or other imaginative forms.

*WR242 - Introduction to Imaginative Writing

Credits - 3 Lecture -3

A course in creative writing designed for those who wish to express themselves in fiction, nonfiction, drama, poetry, or other imaginative forms.

*WR243 - Introduction to Imaginative Writing

Credits - 3 Lecture -3

A course in creative writing designed for those who wish to express themselves in fiction, nonfiction, drama, poetry, or other imaginative forms.

^WR298 - Special Studies

Credits - 1-3

Designed to provide interested and capable students with the opportunity to study special topics in writing.

Symbols: ^ - Elective + - Lab Science
* - Group Distribution > - C/T Elective

BMCC Boards and Personnel

BMCC Board of Education

Molly Anne Rill
Zone 1, Term Expires 2011

Kenneth Dudley
Zone 2, Term Expires 2011

Laura Kordatzky
Zone 3, Term Expires 2009

Kim Puzey
Zone 4, Term Expires 2009

Doug Voyles
Zone 5, Term Expires 2011

Anthony Turner
Zone 6, Term Expires 2009

Bryan Branstetter
Zone 7, Term Expires 2011

Oregon Board of Education

Jerry Berger
Salem—5th Congressional District

Leslie Shepherd
Hammond—2nd Congressional District

Brenda Frank
Klamath Falls—At Large

Artemio Paz, Jr.
Springfield—4th Congressional District

Nikki Squire
Bend—At Large

Duncan Wyse
Portland—1st Congressional District

Lewis Frederick
Portland—3rd Congressional District

BMCC Foundation Board of Directors

Bob Byrd
Irrigon, Term Expires 2009

Gary Schmidtgall
Athena, Term Expires 2008

Russell Dorrان
Hermiston, Term Expires 2009

Deb Sue Hamby
Pendleton, Term Expires 2008

Lorrene Montgomery
Lexington, Term Expires 2009

Wesley Grilley
Pendleton, Term Expires 2010

Tracy Gammell
Hermiston, Term Expires 2010

Betty Rietmann
Ione, Term Expires 2010

Carole Innes
Pendleton, Term Expires 2010

Ron Daniels
Keizer, Term Expires 2008

Ellsworth Mayer
Pendleton, Term Expires 2009

Bill Broderick
Hermiston, Term Expires 2009

Dotty Miles
North Powder, Term Expires 2009

Lonnie Read
Pendleton, Term Expires 2010

Margaret Gianotti
Pendleton, Executive Director

Administration

John Turner (2003)

President
B.A., University of Oklahoma
M.A., Catholic University of America
Fellowship, MIT

Larry Bundy (2001)

Vice President, Information Technology
B.A., Central Washington University
B.S., Central Washington University
M.B.A., University of Utah
Ph.D., University of Utah

Art Doherty (2004)

Associate Vice President, Human Resources
B.A., Campbell University

Harvey Franklin (2005)

Associate Vice President Enrollment Management
A.S., Central Oregon Community College
B.S., Oregon State University
M.S., Oregon State University
Ph.D., University of Oregon

Arthur Hill (2001)

Vice President, Economic Development
B.A., Boston University
M.B.A., University of Bridgeport

Peggy Hudson (2006)

Associate Vice President,
BMCC-Baker County
A.A., Central Oregon CC
B.B.A., University of Oregon
M.A., San Francisco State

Daniel Lange (1983)

Vice President, Instruction
B.M., University of Montana
M.M., University of N. Colorado

Debbie Lee (2007)

Associate Vice President
BMCC Milton-Freewater
B.S., Oregon State University
M.Ed, Oregon State University

Kevin McCarthy (2007)

Associate Vice President, Instruction
B.A., University of Virginia
M.A., University of Mississippi
Ph.D., University of Mississippi

Margaret Saylor (1975)

Associate Vice President,
BMCC-Hermiston/Boardman
B.S., Eastern Oregon University
M.A., Oregon State University

N. Clark Williams (2007)

Vice President, Operations
B.S., US Naval Academy
M.S., Stanford University

BMCC Faculty

(As of January 2008)

Lower Division Collegiate and Career and Technical Programs

Full-Time Faculty

Jan Acsai (1991)

Instructor of Biology

A.S., West Valley Junior College

B.S., Humboldt State University

M.A., Humboldt State University

Ph.D., Colorado State University

Shaindel Beers (2006)

Instructor of English

B.A., Huntington College

M.A., University of Chicago

M.F.A., Vermont College

Gregory A. Berlie (1986)

Instructor of English

B.A., California State University

M.A., California State University

Michael Booth (1989)

Instructor of Art

B.F.A., Utah State University

M.F.A., Utah State University

Lincoln A. DeBunce (1999)

Instructor of Geography and Anthropology

B.S., Southern Oregon University

M.A., Louisiana State University

Ph.D., University of Oregon

Robert L. Hillenbrand (1998)

Instructor of Mathematics

A.A., Seattle Central Community College

B.S., University of Washington

M.S., Western Washington University

Arlene G. Isaacson (1997)

Instructor of Education

B.A., Mt. Angel College

M.S., Indiana University

Ph.D., University of Oregon

Rob Johnson (2007)

Instructor of Diesel Technology

Certificate, Clark Community College

Llewellyn (Wells) Jones (1995)

Instructor of Physical Education

B.S., Lewis Clark State College

M.S., University of Oregon

David H. Krumbein (1986)

Instructor of Civil Engineering

Technology

B.S., Oregon State University

Cindy A. Lenhart (1991)

Instructor of Education

B.S., Eastern Oregon University

M.S., Eastern Oregon University

Carol Lovell (2003)

Instructor of Nursing

B.S., Oregon Health Sciences University

Craig McIntosh (2005)

Instructor of Theatre Arts

B.A., Lewis and Clark

M.F.A., University of California

Helen Marchio (2007)

Instructor of Nursing

B.S., Arizona State University

M.S., University of Phoenix

Christina E. Martinez (1994)

Instructor of Sociology

B.A., California State University-Fullerton

M.A., California State University-Fullerton

Margaret M. Mayer (2001)

Instructor of Music

B.A., Linfield College

M.M., Michigan State University

Ph.D., University of California-Santa Barbara

Michelle Miller (1995)

Instructor of Science

B.S., University of Idaho

M.S., University of Oklahoma

Catherine B. Muller (2005)

Instructor of Mathematics

B.A., Eastern Oregon University

M.A., Eastern Oregon University

Michael W. Muller (1991)

Instructor of Civil Engineering Technology

B.S., Eastern Oregon University

B.Arch., University of Idaho

Ron Neeley (2004)

Instructor of Business

B.S., Eastern Oregon University

B.S., Central Washington University

M.B.A., Portland State University

Nick Nelson (2007)

Instructor of Animal Science

A.A., Lassen College

B.S., California State University

M.A., Oregon State University

Gary D. Parker (1996)

Instructor of Mathematics

A.S., Community College of Rhode Island

B.A., Rhode Island College

M.S., Western Washington University

Crystal D. Patton-Doherty (1989)

Instructor of Dental Assisting

Certificate, Blue Mountain Community

College

B.S., Eastern Oregon University

Mark L. Petersen (1978)

Instructor of Science

B.S., Southern Colorado State College

M.A., San Francisco State University

Ph.D., University of Oregon

Melinda S. Platt (2002)

Instructor of Business Technology

B.S., Eastern Oregon University

M.T.E., Eastern Oregon University

Laurie Post (2004)

Instructor of Nursing

A.S., Walla Walla Community College

B.S., Gonzaga University

M.S., Oregon Health Sciences University

Teresa L. Quesenberry (1986)

Instructor of Business Technology

B.S., Eastern Oregon University

M.S., University of Idaho

Douglas B. Radke (1993)

Instructor of Speech

B.A., Seattle Pacific University

M.Div., Bethel Theological Seminary

M.A., Portland State University

Sara Reyburn (2000)

Instructor of Psychology

B.S., Pittsburg State University

M.S., Pittsburg State University

Philip Schmitz (2008)

Instructor of Geology & Physics

B.S., University of Notre Dame

M.S., University of Utah

Kevin Seward (2007)

Instructor of Chemistry

B.A., Iowa State University

B.S., University of Wyoming

Ph.D., University of Wyoming

Elizabethe A. Sweet (1998)

Instructor of Dental Assisting

C.D.A., Portland Community College

Alison Timmons (2005)

Instructor of English

B.A., Washington State University/Columbia

Basin College

M.A., University of Manchester

Terry A. Vogel (1984)

Instructor of Nursing

A.S., Blue Mountain Community College

A.A.N., Portland Community College

B.S.N., Oregon Health Sciences University

M.S., University of Portland

Scott Waggoner (2008)

Instructor of Diesel Technology

A.A., Blue Mt Community College

Ronald W. Wallace (1983)

Instructor of Mathematics and

Computer Science

B.A., Azusa Pacific College

M.S., California State Polytechnic University

Scott Wallace (1993)
Instructor of Business Technology
B.A., Brigham Young University
M.A., Brigham Young University

Dale J. Wendt (1979)
Instructor of Agriculture
B.S., California State Polytechnic University
M.S., California Polytechnic State University

James K. Whittaker (1996)
Instructor of Mathematics
B.S., Oregon State University
M.E., North Carolina State University
Ph.D., North Carolina State University

Preston H Winn (1991)
Instructor of Agriculture
B.S., Oregon State University
M.Ed., Oregon State University

Part-Time Faculty

Patty Allery-Lane (2003)
Instructor of Mathematics
B.S., Eastern Oregon University
M.S., Eastern Oregon University

Linda Anthony (2004)
Instructor of Speech and Philosophy
A.A., Modesto Jr. College
B.A., California State University
M.A., California State University

Steven Bachman (2007)
Instructor of Human Anatomy &
Physiology
B.S., University of Oregon

Larry Bartee (1984)
Head Basketball Coach – Men
Instructor of Physical Education
B.S., Central Methodist
M. Ed., University of Missouri

Dave Baty (2008)
Head Volleyball Coach
Instructor of Physical Education

Thomas W. Bequette (2005)
Head Softball Coach
Instructor of Physical Education
Diploma, John Burroughs

Brett Bryan
Instructor of Physical Education
B.S., Eastern Oregon University

Larry Bundy (2001)
VP, Information Technology
Instructor of Economics
B.A., Central Washington University
B.S., Central Washington University
M.B.A., University of Utah
Ph.D., University of Utah

Janie Burcart (2007)
Instructor of Criminal Justice
B.A., University of Sussex
M.A., University of New Mexico

Billie Burns (1999)
Instructor of Health & Physical Ed
B.S., Oregon State University
M.A., University of New Mexico

Elizabeth Burton (2007)
Instructor of Business Technologies
B.S., University of Oregon
M.B.A., Eastern Oregon University

Tygh Campbell (2001)
Head Rodeo Coach
Instructor of Horse Trimming
A.A.O.T., Blue Mt Community College

Webster Castaneda (2004)
Instructor of Spanish
B.A. Eastern Washington University
M.Ed., Washington State University

Timothy D. Colley (2004)
Instructor of English
B.A., Gonzaga University
M.A., Gonzaga University

Jennifer K. Cooper (2004)
Instructor of Psychology
A.A., Central Oregon Community College
B.S., Western Oregon University
Psy. D., Pacific University

Roger Cooper (2004)
Instructor of English
B.S., Portland State University
M.S., University of Denver
Ed.D., Oregon State University

Diane Cort-Wagner (2006)
Instructor of Nursing
B.S., Oregon Institute of Technology
M.S., University of Portland
M.S. FNP Gonzaga University

Michael Cosgrove (2007)
Instructor of Speech
B.S., Willamette University
M.S., Eastern Oregon University

John Courtney (2006)
Instructor of Criminal Justice
B.A., Cal State University Long
Beach
M.Pa., City University

Cheyleen Davis (2001)
Instructor of Biology
B.S., Central Michigan University
M.S., Central Michigan University

Mary Davis (1977)
Instructor of Nutrition
B.S., Montana State University
M.S., Cornell University

Sharon Defrees (2007)
Instructor of Biology
B.S., Oregon State University
B.S. Eastern Oregon University
M. Ed., Eastern Oregon University

Dorothy E Dielman (2004)
Instructor of English
B.A., Purdue University
M.A., Purdue University
Ph.D., University of Oregon

Karen Eddy (1993)
Instructor of Physical Education
B.S., Eastern Oregon University

Dianne Ellingson (2003)
Instructor of Writing and English
B.A., Augustana College
M.S., Eastern Oregon University

Heather Estrada (2006)
Instructor of Mathematics
B.A., Concordia University

Carol Faulkner (2007)
Instructor of Writing
B.S., Kent State University
M.A., Kent State
Ph.D., University of Oregon

Ruai Gregory (2000)
Instructor of Early Childhood Education
A.S., Grossmont College
B.A., Pacific Oaks
M.A., Pacific Oaks

Jodie Harnden (1997)
Instructor of Geology and Geography
B.S., Western Oregon University
M.S., Western Oregon University

Donald R. Hefner (2005)
Instructor of Business Technology
B.S., Black Hills State

Jan Hood (1988)
Instructor of Computer Science
A.A., Blue Mountain Community College
A.S., Blue Mountain Community College
B.S., Oregon Institute of Technology
M.M.R., University of Georgia

James Houle (2006)
Instructor of Accounting
B.S., Eastern Oregon University

Joyce E. Houle (2006)
Instructor of Education
B.S., Eastern Oregon University

Marvin L House (2005)
Instructor of Mathematics
B.S., Oregon State University/Math
B.S., Oregon State University /Science
M.A., Oregon State University

Robert Irvine (2007)
Instructor of History
B.A., Whitman College
M.M., Willamette University
Ph.D., Kansas State University

Mardel James-Bose (2000)
Instructor of English
B.A., Portland State University
M.A., Portland State University

James R Johnston (2006)
Instructor of Math and Computer Science
B.S., Northern Arizona University
M.B.A., Northern Arizona University

Cheri Kendrick (2002)
Instructor of Speech and
Business Technology
B.A., Oregon State University
M.A., Oregon State University
J.D., Willamette University of Law

Alan L. King (2005)
Instructor of Human Development
B.A., Eastern Oregon University
M.A., Walla Walla College

Carel Landess (2000)
Instructor of Business
A.A., Western Business College
M.P.A., Portland State University

Charles (John) Larson (2003)
Instructor of English
B.A., Concordia
M.A., Eastern Oregon University

Rochelle Ledbetter (2006)
Instructor of Business Technology
B.S., Eastern Oregon University
David Lindley (2006)
Instructor of Business Technology
B.S., University of Oregon

David Lindley (2006)
Instructor of Business Technology
B.S., University of Oregon

David Marshall (2003)
Instructor of Business Technology
B.A., Whitman College
M.A., Evergreen State College

Ryan Marvin (2007)
B.S., Eastern Oregon University
M.S., Stockholm University

Dan Mildon (2007)
Instructor of Business Technology
B.S., Washington State University
MBA, University of Washington

Edgar Montellano (2004)
Instructor of Spanish
B.S., Universidad de Celiaya
B.A., Portland State University
M. Ed., Portland State University

Jon Oravec (2004)
Instructor of Business Technology
B.A., California State

Christina Pierson (2007)
Instructor of Business Technology
B.A. Eastern Oregon University

Theresa Pihl (1995)
Instructor of History
B.A., University of Portland
M.A., Washington State University

Jay Rogers (2005)
Instructor of Math
B.S., Oregon State University
M.S., Eastern Washington University

Rima Sanders (2006)
Instructor of Criminal Justice
B.S., Eastern Oregon University
M.S., Michigan State University

Susanna Schaufler (2007)
Instructor of English and Writing
B.A., University of Montana
M.A., Portland State University
M.F.A., University of California Irvine

Michael Shaw (2001)
Instructor of Social Science
B.A., Eastern Washington University
M.A., Gonzaga University

Fred Sheely (1992)
Instructor of Computer Science
B.A., University of Idaho
M.A., University of Oregon

Kenneth Simpson (2005)
Instructor of Science
B.S., Los Angeles College

Sandra Snook (2005)
Instructor of Early Childhood
Education
A.A.S., Blue Mountain Community College
B.A., Pacific oaks College
M.A., Pacific Oaks College

Taryn Suchy (2002)
Instructor of Computer Science and History
B.A., Eastern Oregon University
M.A., Eastern Oregon University

Alden Taylor (2007)
Instructor of Music
B.M., Willamette University
M.M., University of Oregon

G Ann Thomas Heddle (2004)
Instructor of Writing
A.A., Blue Mountain Community College
B.A., Eastern Oregon State College
M.A., Eastern Oregon State College

Lorna Tonack (2002)
Instructor of Spanish
B.S., Whitman College
M.S., Eastern Oregon University

Timothy Zacharias (2004)
Instructor of History
A.A., Judson Baptist College
B.A., Oregon State University
M.A., Washington State University
Teacher Certificate, Portland State University

Toni Zikmund (2001)
Instructor of Business Technology
B.S., Eastern Oregon University

College Preparatory Programs

Full-Time Faculty

Brian K. Bradley (2001)
Instructor
B.A., University of Montana

Marianne I. Burch (2001)
Instructor
B.S., Western Oregon University
M.A., Golden Gate Baptist Theological Seminary

Tamara L. Chorey (2001)
Instructor
A.A., Oakland Community College
B.S., Oregon State University

Cheryl Haertling (2005)
Instructor
B.A., California State University

Walter (Stanley) Johnson (2004)
Instructor
B.A., Seattle Pacific University
M.A., George Fox University
Ph.D., St. Louis University

Greg Jones (2005)
Instructor of ABE/ESL
M.A., Oregon State University
B.A., Oregon State University

Doreen Matteson (2001)
Instructor
B.S., Virginia Polytech University

Shannon Maude (2001)
Instructor
B.A., Southern Oregon University
Ed.M., Oregon State University

Sharone McCann (1985)
Instructor
B.A., California State University
Ed.M., Oregon State University

Dulcie Peterson (2003)
Instructor
AAOT, BMCC
B.A., Eastern Oregon University

Catherine Pinkerton (1991)
Instructor
B.A., Whitman College

Bri Lynn Reed (2004)
AAOT, Blue Mountain Community College
B.S., Eastern Oregon University

Natalie J. Sanusi (1999)
Instructor
B.A., University of Oregon

Carrie J. Swanson (1991)
Learning Disabilities Diagnostician
A.A., Blue Mountain Community College
B.S., Eastern Oregon University

Florene VanDonge (1993)
Instructor
B.A., Eastern Washington University

Jason C. Villers (2001)
Instructor
A.A., Spokane Falls Community College
B.A., Eastern Washington University

Sirpa S. Whitman (2002)
Instructor
A.A., Sacramento City College
B.A., Portland State University
T.E.S.L., Portland State University
M.A., University of Oregon
M.P.A., University of North Carolina

Jeanine Youncs (2007)
Instructor
AAOT., Blue Mountain Community College
B.S., Eastern Oregon University

Part-Time Faculty

Jacquelyn Bartron (1995)
Instructor
B.S., Eastern Oregon University
M.Ed., Eastern Oregon University

Shirley M. Deford-Heisey (2001)
Instructor
B.A., Walla Walla College

Ann Dennis (2006)
Instructor of College Prep/Skills Development
B.S., Eastern Oregon University

Susan G. Hollis-Shade (1999)
Instructor
B.A., University of Portland

Sandra Holtz (2007)
Instructor
B.A., University of Oregon

Ingrid Larsen (1996)
Instructor of Mathematics
B.S. Brigham Young University

Roberta B. Lewis (1991)
Instructor
B.S., University of Oregon

Zoe Lindsay (2006)
Instructor of College Prep
B.A., University of Scranton

Ricardo Martinez-Dominguez (1999)
Instructor
Conalep College-Morelia, Mexico Centro
Mexicano Internacional

Stacey A. Merrigan (1999)
Instructor
B.S., University of Idaho

Leon Myers (2002)
Instructor
B.A., Boise State College

Carol J. Nevin (1991)
Instructor
B.A., University of Montana

Katherine Palmer (2000)
Instructor
A.S., Blue Mountain Community College
B.S., Eastern Oregon University
M.S., Oregon State University

Diane Pearson (2002)
Instructor
B.A., Albertson's College of Idaho
Ed.M., Wichita State University

Marjorie A. Prowant (1978)
Instructor
B.S., Ball State
M.A., Ball State

Amanda Pugh (2002)
Instructor
B.S., University of Oregon
M.L.S., University of Oregon

Sonia Sanchez (2006)
Instructor
B.S.W., Eastern Washington University
M.S.W., Eastern Washington University

Victoria Scott (2007)
Instructor
B.S., Eastern Oregon University

Elizabeth Shane (2007)
Instructor
B.S., Western Oregon University
M.S., Walden University

Linda M. Stark (1994)
Instructor
A.A., Glendale College
B.A., University of California-Berkley

Diana Stroe (2004)
Instructor
B.S., Eastern Oregon University

Sandra Vandever (2001)
Instructor

Directors, Coordinators, and Managers

Jacquelyn Bartron (1995)
Coordinator, Dual Credit
B.S., Eastern Oregon University
M.Ed., Eastern Oregon University

Kathy Beck (2003)
Coordinator, Early Childhood Education
A.S., North Idaho College
B.S., University of Idaho
M.S., Western Oregon University

Theresa Bosworth (1989)
Registrar/Director of Admissions, Records
and Testing
A.A., Blue Mountain Community College
B.S., Eastern Oregon University

Brett Bryan (1993)
Athletic Director
B.S. Eastern Oregon University

Jennifer Gambill (2008)
Coordinator, Community Education
Diploma, Pendleton High School

Margaret Gianotti (2006)
Executive Director, BMCC Foundation
Diploma

Phillip Glise (2008)
Director Corrections Education—Two Rivers
Correctional Institution

Karen Graybeal (2004)
Director, Student Financial Assistance
B.A., Washington State University

Diana Hammon (1989)
Director, Instructional Operations
A.A., Blue Mountain Community College
B.S., Eastern Oregon University

Rhonda Harguess (2007)
Coordinator, Grant County
B.S., Eastern Oregon University

Karen Hill (1996)
Director, Public Relations
B.S., Eastern Oregon University

Jennifer Hills (1994)
Coordinator, Apprenticeship Program
B.S., University of Idaho
M.Ed., Eastern Washington University

Rhonda Holcomb (2008)
Senior Operations Accountant
A.A.S., Accounting Technology

Brad Holden (1989)
Telecommunications Coordinator
Diploma, Pendleton High School

Jan Hood (1988)
Coordinator, Institutional Research
A.A., Blue Mountain Community College

Jubilee Howell (2008)
Coordinator, College Preparation
B.A., Northwest Christian College
Becky L. Kaaen (1992)
Site Coordinator, JOBS Program
B.S., Northern State University

Douglas Lamberson (2006)
Coordinator, Small Business Management
B.B.A., Wichita State University
M.A., Wichita State University

Jane Kilburg (1981)
Manager, JOBS Program
B.S., Oregon State University

Anne Livingston (2008)
Outreach Coordinator
B.S., Washington State University

Naamah Matthew (2004)
Coordinator BMCC Hermiston/Boardman
B.A., Eastern Washington University

Martha McCarthy (2007)
Director, Alumni Relations
B.A., University of Mississippi, Oxford
M.A., University of Mississippi, Oxford

Joe Montes
Senior Director College Prep
B.S., University of Arizona
M.A., University of Phoenix

Anne Morter (1993)
Coordinator, South Morrow County
A.A., Lane Community College
B.A., Eastern Oregon University

Wade Muller (2005)
Assistant Director, Admissions and Advising
B.S., Montana State University

Janet Narum (2008)
Director of Corrections – Eastern Oregon
Correctional Institution
B.A., Washington State University

Jenny Nelson (2007)
Coordinator, Grant County
B.S., Oregon State University

Donna Richardson (2005)
Director, TRiO Student Support Services
Program
B.S., University of Wyoming
M.A., University of Wyoming

Susan Plass (2002)
Director, Grants
A.A., College of the Siskiyou
B.A., California State University-Chico
M.A., University of Oregon
Certificate, University of Oregon

Steven Platt (1985)
Supervisor, Buildings and Grounds
A.S., Blue Mountain Community College

E. Karl Schrader (2004)
Manager, BMCC Bookstore
B.A., University of Washington

Beth J. Smith
Director FIPSE Project
B.A., Washington State University
Ed.M., Washington State University

Robert Tally (1996)
CRT, NRI Schools

Jim Tomlinson (2003)
Coordinator, Criminal Justice
B.S., Marylhurst College
M.A., Lewis & Clark College

Shannon Van Kirk (2006)
Director, Library and Media Services
B.A., Immaculate Heart College
MLIS University of Alabama

John R. Wooten (2004)
Coordinator, Emergency Medical Services
A.A., Blue Mountain Community College

Glossary

Terms Needed for College Success

A.A.O.T.: Associate of arts Oregon transfer degree. A *non-designated* block transfer degree, usually consisting of 90 credits and designed for the student who intends to transfer to a four-year college or university with the Oregon University System (OUS). *Students need to work closely with an academic advisor to plan their program of study at BMCC.*

A.A.S.: Associate of applied science degree. A non-transfer degree awarded to students who complete the requirements of a two-year program, usually a 93-credit designated program as outlined in the college catalog.

A.S.: Associate of science degree. A non-designated college-transfer degree designed for students whose program requirements do not fit A.A.O.T. degree patterns. This degree does not always “block transfer” to Oregon universities.

A.G.S.: Associate of general studies degree. A terminal, two-year, 90-credit program of study that yields a non-designated and non-transferring degree, although some, or possibly all, of the courses may be accepted by another institution of higher education.

(In every case above, students should verify course transferability for each program of study before transferring to another college or university. Even in Oregon, particular schools may have some differences in lower division credits required for their programs.)

Academic Advisor: An assigned BMCC faculty or staff member trained to assist the student in developing and managing the completion of the student’s program of study based on the documented assessments and declared educational goals within the student’s individual strategic action plan.

Academic Calendar: Start and end dates of the academic year and of each quarter. The calendar reflects deadlines and other information related to payment schedules, add/drop options, graduation applications, and related policies.

Academic Records: The official listing of courses attempted and completed by a student at BMCC, including the credits accepted as a result of the BMCC registrar’s evaluation of official transcripts from other institutions. This information is listed in the student management module of the integrated administrative system, WolfTrax, and is accessible to the student through WolfWeb.

Academic Year: The four-quarter sequence beginning in summer and ending the following spring.

Academic Notification of Warning, Probation, and Suspension: An official process by which degree-seeking students who do not achieve satisfactory academic progress receive a specific level of notice whenever their term grade point average (GPA) falls below 2.00 or their cumulative GPA falls below 2.00. *See page 19 for detailed information.*

Advanced Placement (AP): The national exam for high school students that allows the granting of credit based on points earned and recorded on the official AP transcripts. Earned points of 4 and 5 are considered evidence that the student has mastered the equivalent of an introductory course in English or history at BMCC.

Articulation: The linkage of curriculum between two (or more) institutions through an agreement that the content and difficulty level of similar courses offered by each institution are equivalent and that students taking the articulated course at one institution will not need to repeat it when they transfer to the other institution.

Associate’s Degree: A degree granted to students who complete a specific program of study usually totaling 90 quarter credits or more. BMCC offers two transferable associate’s degrees, the associate of arts Oregon transfer (A.A.O.T.) and the associate of science (A.S.). BMCC also offers an associate of general studies (A.G.S.) degree and an associate of applied science (A.A.S.) degree, as well as module and certificate programs in a variety of subjects. Individual courses taken to fulfill the requirements of any of these degrees or programs may be transferable to another college or university.

Audit: Taking a credit class without being required to participate fully in the class activities (taking tests or doing homework). Classes taken under audit status do not count as credits attempted in financial aid calculations and the AU status does not count in calculating GPAs.

BMCC Campus: BMCC’s main campus is located in Pendleton.

BMCC Center: Within the Blue Mountain Community College system, four outreach centers serve the college's district, which includes Baker, Morrow, and Umatilla counties. Centers are located in Baker City (Baker County), Boardman (north Morrow County), Hermiston, and Milton-Freewater. A smaller office in Heppner serves south Morrow County.

Certificate Program: A specified program of study leading to an official award and notation on the transcript. BMCC awards certificates to students who complete certain career and technical or postsecondary programs requiring less than two years of college study and who earn a GPA of no less than a 2.00, or C average.

Class Roster: The official list of students' names enrolled in a particular class.

Cohort: A group, regardless of size, of individuals that can be identified by at least one identifiable characteristic.

College Preparatory Programs: A BMCC department administering classes and activities related to English as a Second Language (ESL), Adult Basic Education (ABE), General Educational Development (GED), Adult High School Diploma (AHS), Credit Retrieval, post-secondary remediation up to the 60 level, and tutoring.

Competency: A specific skill in a specific area of study.

Contracts Out Of District (CODs): Within the Blue Mountain Community College system, there are three counties (Grant and Wallowa) that lie outside the BMCC district but that contract with the college for educational services. BMCC has COD offices in John Day and Enterprise.

Corequisite: A course or activity that is required to be taken simultaneously with the course described.

Core Curriculum: Courses required for a specific major. Courses in the core curriculum usually must be taken for a grade (pass/no pass is not allowed) to count toward degree requirements.

Course/Class: An organized unit of instruction within an academic discipline or subject of study, or one of the instructional subdivisions of a discipline or subject area.

Course Description: The paragraph in the course catalog that describes a course's emphasis and content; the description also may specify prerequisites, corequisites, recommended preparation, and credit hours.

Credit: A measurement of course work and time spent in an academic endeavor. One credit generally equates to fifty minutes (a clock hour) of instruction and two hours of preparatory work outside the instructional classroom each week, or the equivalent thereof. Credits and clock hours may vary depending upon the type of course.

Credit Load: The total number of credits taken in a given term.

CUESTE: (*pronounced "quest"*) Curriculum of Undergraduate Elementary and Secondary Teacher Education. CUESTE is a highly prescriptive teacher-education program at Eastern Oregon University (EOU) provided to students within their local community college districts in collaboration with the community college.

Curriculum: An organized program of study.

CWE: Cooperative work experience, a program of study in a work environment for which students, instructors, and participating businesses develop written training and evaluation plans to guide student development within specific programs. Students receive course credit for their work experience, whether or not they are paid a wage.

Designated Degree: A set of courses required for a specific degree in a career and technical area. The A.A.S. degree is the only designated degree offered at BMCC.

Distance Education: The delivery of instruction to students located throughout the district, state, nation, and the world using a variety of technologies and telecommunications networks. Delivery systems include interactive television (ITV), video recorded instruction, online instruction, guided instruction, and hybrid courses.

Drop: The process of removing one's name from the class roster within the 100 refund period for a course or courses. This procedure results in a full refund. There is no record of the student's having ever registered for the class, and no grade is reflected on the transcript.

Electives: Courses that students may choose to take, as contrasted with courses that are required for an academic program.

Emphasis: A concentration or specialization within a program or academic option that provides additional curricular focus. *An emphasis does not appear on a transcript except in the A.A.S. degree and certificate programs.*

English as a First Language (EFL): Used primarily in a college preparatory setting to denote students whose native language is English.

English as a Second Language (ESL) or English Language Learner (ELL): Terms that denote students or a program for students who want to improve their English language proficiency in order to perform effectively in an academic, work, or community setting. Many college preparatory classes are structured specifically for ESL and ELL students.

Enrollment: The placement of a student within a credit or non credit course. Enrollment and registration are interchangeable terms from a student standpoint. From an institutional standpoint, registration is the process of enrollment and enrollment is a status.

Enrollment Management (EM): The college's administrative unit consisting of the following functions: admissions, records and testing; advising; financial aid and veterans' benefits; student employment; services for students with disabilities; recruitment and marketing; and TRiO Student Support Services. In addition, the Associated Student Government reports to the senior director for enrollment management. The EM offices provide services to students in such areas as: official grades and transcripts; degree, credit, and transfer-transcript audits; international student services; academic achievement recognition; issuance of diplomas; satisfactory academic progress; student safety; student dispute resolution; student orientation; student success strategies; and emergency loans and other forms of financial assistance.

Ethnic/Racial Group: An ethnic or racial category with which a person most closely identifies. Federal and state regulations require BMCC to report aggregated ethnic/racial information and other demographic statistics for its employees and students. The categories listed on federal reports are: American Indian/Alaskan Native, Asian/Pacific Islander, Black, Hispanic, and White. BMCC ethnic/racial reports also include "unknown" and "not reported" categories for students who may be of mixed race or heritage and do not identify with or select any of the categories as listed, who choose not to respond to the query, or who check "unknown" or "not reported" on the data collection form. These ethnic categories do not include international students, who are reported separately.

Faculty: The group of employees whose primary assignment is instructional support of the academic mission.

FAFSA: The federal form entitled "Free Application for Federal Student Aid." A completed FAFSA is required for students to be considered for federal financial aid. It is available in hardcopy from BMCC or at a local high school. It is also available online.

Financial Aid Package: A combination of financial student-support mechanisms (such as a scholarships, grants, loans, and work-study) determined by the BMCC Office of Financial Aid and Veterans' Benefits.

First-Generation College Student: Defined at BMCC as a student whose parents have not earned an associate's degree or higher.

First-Time Freshman: A student with fewer than 45 credits who has enrolled for the first time in college.

Full-time Student: A student enrolled in 12 or more credits in any one term as of the FTE (full-time equivalent) reporting date established by the Oregon Community College Unified Reporting System (OCCURS). The Financial Aid and Veterans definitions may vary.

General Education (Gen. Ed.) Requirements: Courses in the conventional divisions of arts and humanities, social sciences, and math and science that provide students with a broad educational experience. General education courses are typically introductory in nature and provide students with fundamental skills and knowledge. Students seeking an A.A.O.T. or an A.A.S. degree from BMCC and/or planning to transfer to a four-year academic institution often take these required courses while attending a community college in preparation for successful transition as a junior in pursuit of their baccalaureate degree.

Grade: A mark indicating a degree of academic accomplishment.

Grade Point Average (GPA): A computation of work done at BMCC and at other academic institutions. Grade points are computed on the basis of: 4 points for each credit of A, 3 points for each credit of B, 2 points for each credit of C, 1 point for each credit of D, and 0 points for each credit of F. All assigned courses, regardless of curriculum, are included in the BMCC cumulative grade point average. To compute your GPA, take the number of points for your grade, multiply them by the number of credits for that class (for example, if you received an A for a four-credit class, you would have a total of 16 points), and divide the total points by total credits. All marks except A, B, C, D, and F are disregarded in the computation of grade point averages; however, some of these disregarded marks will affect financial aid and athletic eligibility. *Honors GPA and graduation are calculated differently (see below).*

Grant: An award of student financial support that does not require repayment and is based on financial need.

Honors: An official recognition of students with exceptional academic qualifications; such students may graduate with honors or high honors. For honors designation, students must have a cumulative GPA of 3.40 to 3.84 in all courses that meet degree requirements. The high honors designation requires a cumulative GPA of 3.85 or higher in all courses that meet degree requirements. The cumulative GPA calculation will include all courses taken at BMCC and other institutions as long as they apply to the degree requirements.

Hybrid Course: A class that uses multiple presentation options, such as a combination of interactive television (ITV) and videotapes.

Individual Strategic Action Plan (ISAP): The collection of assessment information and data for an individual degree-seeking student that drives the decisions involved in declaring a program of study and defining educational goals. The ISAP is used in conjunction with the expertise and advice of the student's assigned academic advisor.

In-State Resident: As defined for tuition purposes, a U.S. citizen or national whose primary residence is in Oregon, Washington, Idaho, Wyoming, Nevada, Montana, or California.

Interlibrary Loan Service (ILL): A service provided by the Library and Media Services Center through which BMCC's centers and students, as well as the general public, may obtain materials on temporary loan from other libraries nationwide.

International Student: As defined for tuition purposes, a person who is not a citizen or a national of the United States and who is in this country temporarily and specifically to obtain a postsecondary educational degree. BMCC assesses an international student the same rate of tuition as a student who is classified as a nonresident alien; an international student pays the same amount for fees and books as any other student.

Junior: Usually defined by four-year institutions as a student with 90 quarter credits of 100-level or higher course work.

Kiosk: A computer work station made available by BMCC to students for accessing the WolfWeb and all online resources.

Major: An extensive program of study in a designated subject area offered at four-year institutions; students seeking a bachelor's degree must declare a major and complete all of its requirements. There are no majors offered at BMCC.

Matriculation: Advancing through the educational process toward a goal, particularly related to enrolling in a college or university (for example, upon completing the A.A.O.T. degree at BMCC, a student may to matriculate to Eastern Oregon University).

Minor: A field of specialized study secondary to a major that may be offered by an academic unit at a four-year institution. There are no minors offered at BMCC.

Non-Credit Enrollment: Course offerings in which no credit is awarded for completion; non-credit courses often serve to upgrade skills, maintain licensure, or gain personal enrichment.

Non-Designated Degree: A set of courses fulfilling general education requirements for a transfer degree leading to a baccalaureate degree or for the associate of general science degree, which offers a broad education as opposed to a focused or career study program.

Nonresident Alien: A term used for tuition purposes to define a person who is not a citizen or a national of the United States and who is in this country on a temporary basis and does not have the right to remain indefinitely. The tuition rate for a nonresident alien is different from the resident tuition rate, but a resident alien student pays the same amount for fees and books.

Non-Traditional Student: A student in credit classes or developmental education classes not fitting the traditional student definition.

Online Supplemental Instruction: Additional teaching and learning opportunities in English and Spanish that are offered through the Internet in support of the basic instructional activities of a particular course.

Oregon Transfer Module: A one-year program of study through which a student can complete most, but not all, general education requirements before transferring to a public four-year institution in Oregon.

Orientation: An activity for students that is intended to acquaint them with campus resources and thereby better prepare them for successful learning and navigation within the educational system.

Out-of-State Resident: A term used to assess tuition for a student who is a U.S. citizen or national whose primary residence lies outside Oregon, Idaho, Washington, Nevada, Montana, or California.

Outcome: A term used at BMCC and other institutions that defines institutional expectations and academic standards. Student-learning outcomes are specific statements defining the expected understanding, knowledge, and/or skill-set that a successful student will have obtained upon completing a course. All course syllabi at BMCC list expected student-learning outcomes.

Part-Time Student: For most purposes at BMCC, and consistent with national definitions, a degree-seeking student who is enrolled in fewer than 12 credit hours in a term as of the FTE (full-time equivalent) reporting date established by the Oregon Community College Unified Reporting System (OCCURS). The financial aid and veterans definition may vary.

Peer Tutor: A trained student who works with fellow students to provide, at no additional cost to the recipients, additional instruction in course work that he or she has completed with a grade of B or better.

Placement Test: An assessment of academic preparedness that helps place a student into a specific course addressing the particular skill level identified by the test. BMCC uses placement tests in math, reading, and writing to help ensure a student's success in college.

Preregistration: Allows students to register before the beginning of classes each term. Students should be in good academic standing and have no outstanding financial balance due from a previous term; otherwise they may be prevented from enrolling in classes or be removed from classes until such obligations are met.

Prerequisite: A course or instructional program that students are expected to complete successfully as a necessary requirement before they are permitted to enroll in another course or instructional program that is more advanced.

Quarter: Synonymous with the academic period often called a term at BMCC. There are four quarters in an academic year, beginning with the summer quarter and ending with the following spring quarter.

Registration: The placement of a student within a credit or non credit course. Enrollment and registration are interchangeable from a student standpoint. From an institutional standpoint, registration is the process of enrollment and enrollment is a status.

Resident: For tuition purposes, a student whose primary residence is in Oregon; residents are charged in-state tuition. At BMCC, students who reside in Idaho, Washington, Nevada, Montana, and California are also considered residents.

Resident Alien: A person who is not a citizen or national of the United States and who has been lawfully admitted for permanent residence (and who holds alien registration receipt cards Form I-551/155). A resident alien is assessed tuition at the same rate as a citizen or national of the United States.

Scholarships: Financial support mechanisms awarded to students based on merit or merit plus need. Scholarships do not have to be repaid.

Sequence Courses: Two or more closely related courses in a discipline or subject area, taken in a specified order using chronological numbering.

Sophomore: A student who has completed 45 or more credit hours.

Staff: The category of employees whose primary assignment is administrative support of the academic mission.

Student Identification Number (SID): A unique, official identification number randomly issued by the college for each BMCC student that is used to record, access, and store academic records.

Subject Code: An alphabetical abbreviation used with a course number to indicate an academic subject area, such as MTH for math courses.

Supplemental Instruction: Face-to-face or online teaching and learning opportunities offered by instructors in addition to and in support of the classroom experience.

Syllabus: An outline of a particular course offering that communicates the course's content, learning objectives, and expected performance criteria for student grades.

Term: An academic quarter.

Traditional Student: A student who is between the ages of 18 and 22 years old taking credit-bearing courses and who has received a high school diploma.

Transcripts: The official record of courses and grades attempted or completed by a student. *Official transcripts* must be ordered by the student from an academic institution's enrollment management office. *Transfer transcripts* are records from another school that BMCC uses for admission purposes or for evaluating a student's earned credits that may be accepted toward a program of study at BMCC. Students requesting transfer transcripts from another institution must arrange to have those transcripts sent directly to BMCC's Office of Enrollment Management in order for those transcripts to be considered official and to be used in assessing credits already earned. *Unofficial transcripts* from BMCC are available online through the student's account.

Transition: The process of a student's successful fulfillment of declared educational goals and subsequent advancement to another endeavor as a result of completing those goals. Transitions may occur, for example, from one academic level to the next, from a study program to a job, or from one institution of higher education to another.

TRiO Student Support Services: A federally funded student-support program that provides services to help eligible students succeed in college. The project serves first-generation, low-income, or disabled students who are seeking a college degree and who hold U. S. citizenship.

Tuition and Fees: The total mandatory charges assessed students for enrolling in the institution each term.

Tutor: A person with expertise in specific subject areas to assist students in understanding concepts taught in the classroom. Tutors are available free to the students at most BMCC locations, though they may be available to help only in specific academic areas.

Withdraw: The process of filing the required paperwork when a student abandons an attempt to earn the credits associated with a given course. Both the course and a grade of W appear on the student's transcript. The grade of W is not calculated for GPA; however, a W may affect a student's financial aid. Students withdrawing from classes do not receive a refund of tuition or fees.

WolfTrax: BMCC's software system that manages the college's academic activities, records, procedures, and processes.

WolfWeb: The Internet-based resource that provides BMCC students online access to all of their BMCC information.



**BMCC
CAMPUS
MAPS
AND
DIRECTORY**

BMCC Pendeton 2411 NW Carden Avenue

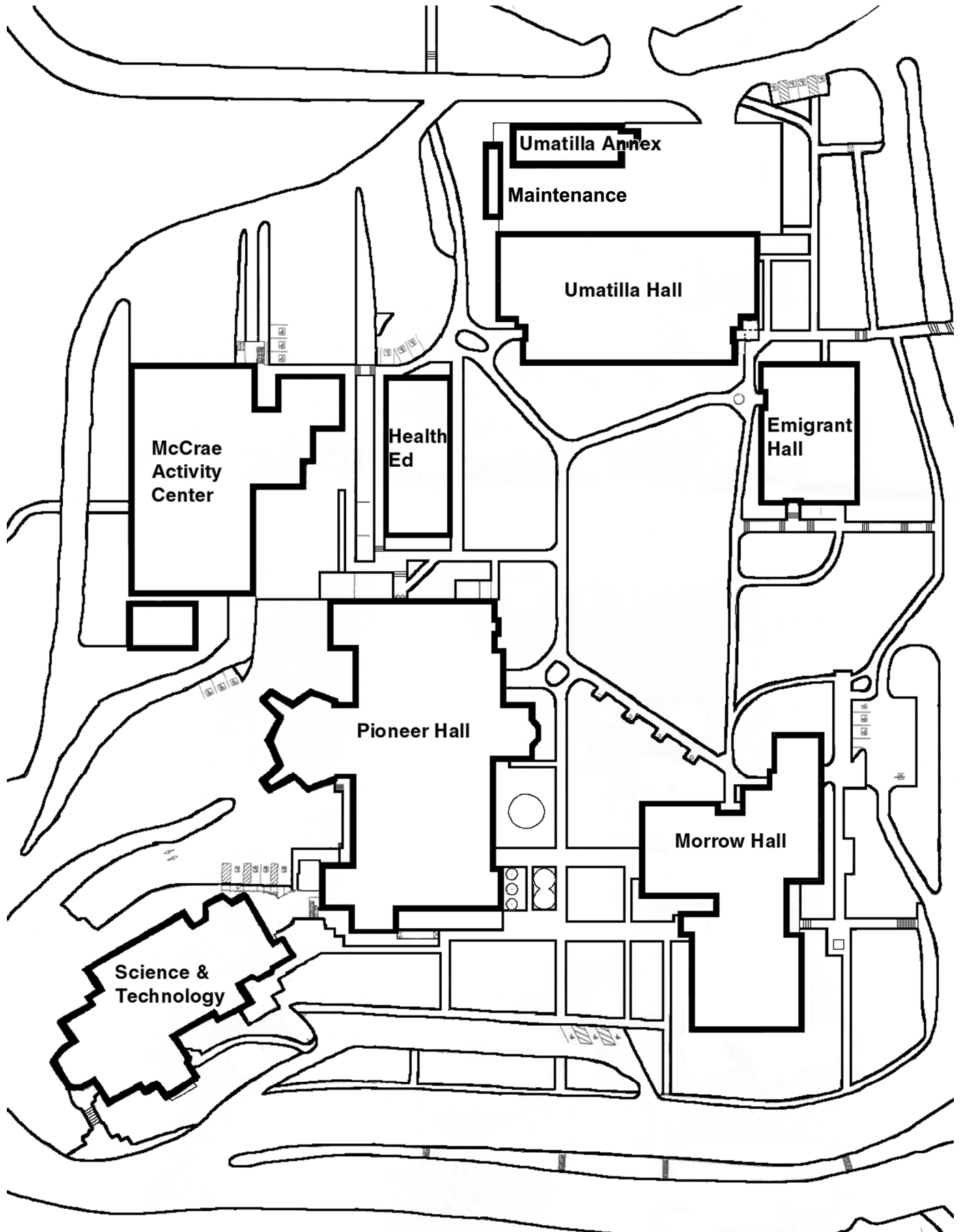

BMCC Hermiston 980 SE Columbia Drive Main Section

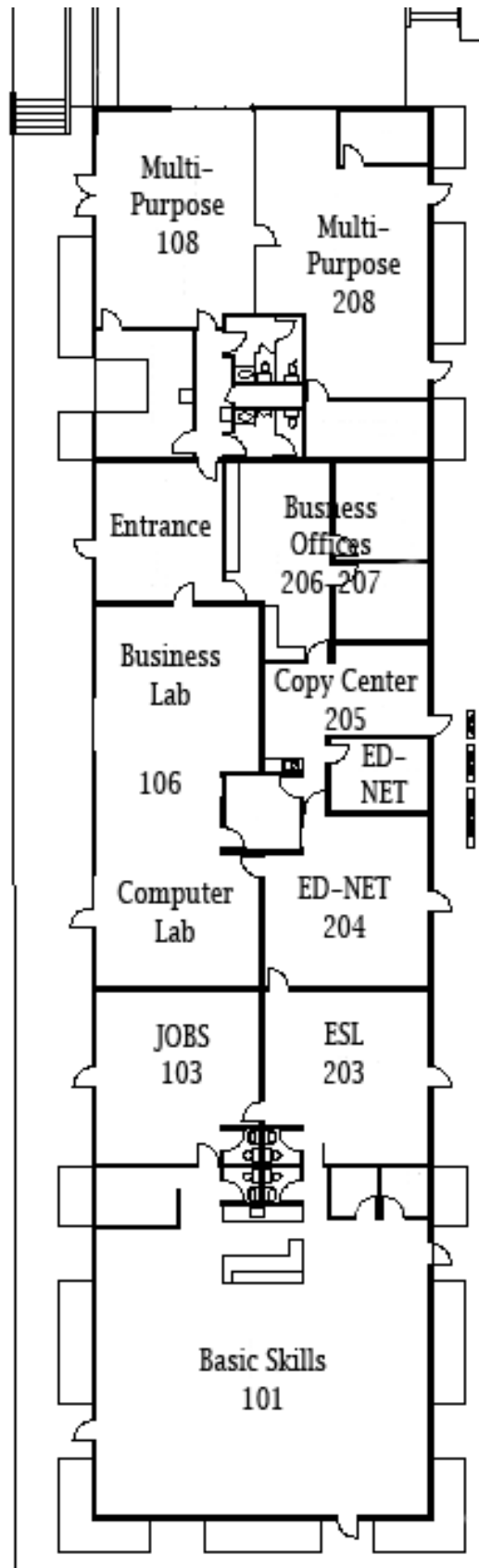

BMCC Hermiston
980 SE Columbia Drive
Second Section

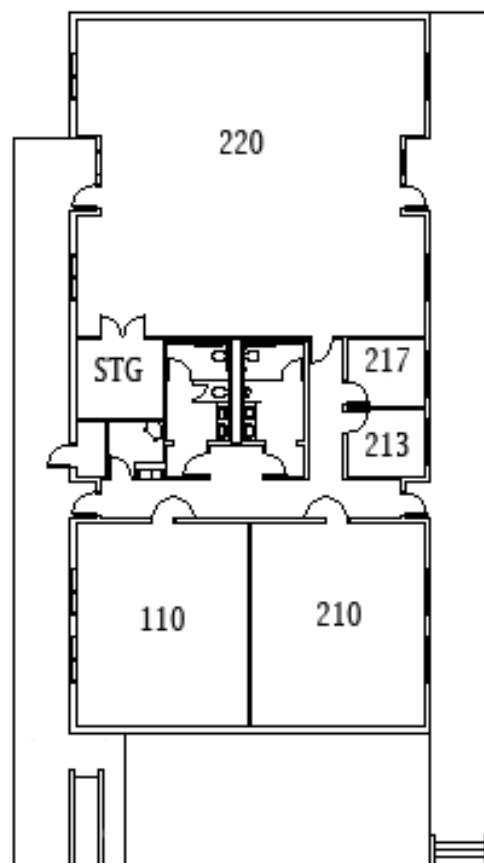

BMCC Milton-Freewater 311 N Columbia

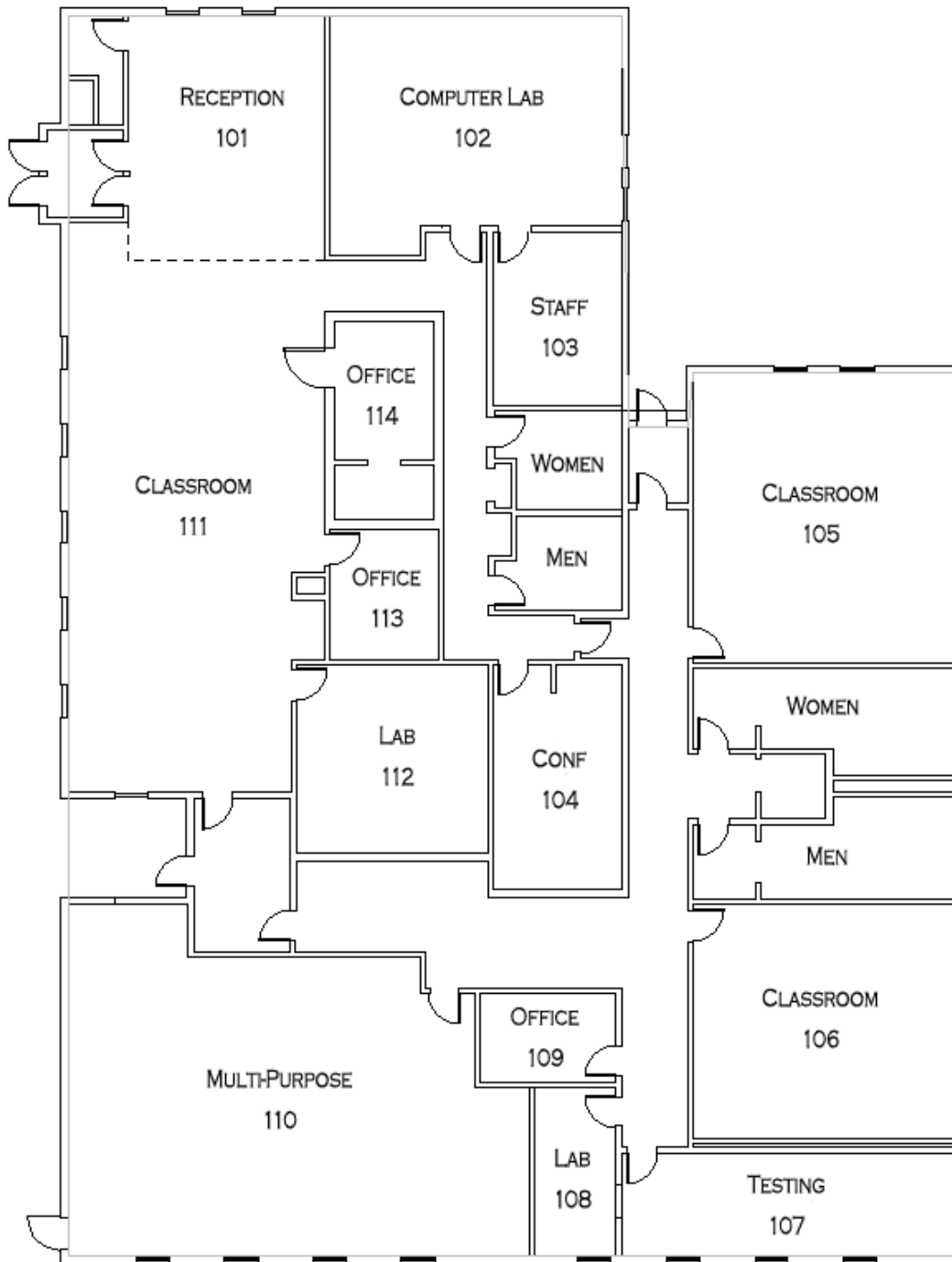

BMCC Baker City 3275 Baker Street

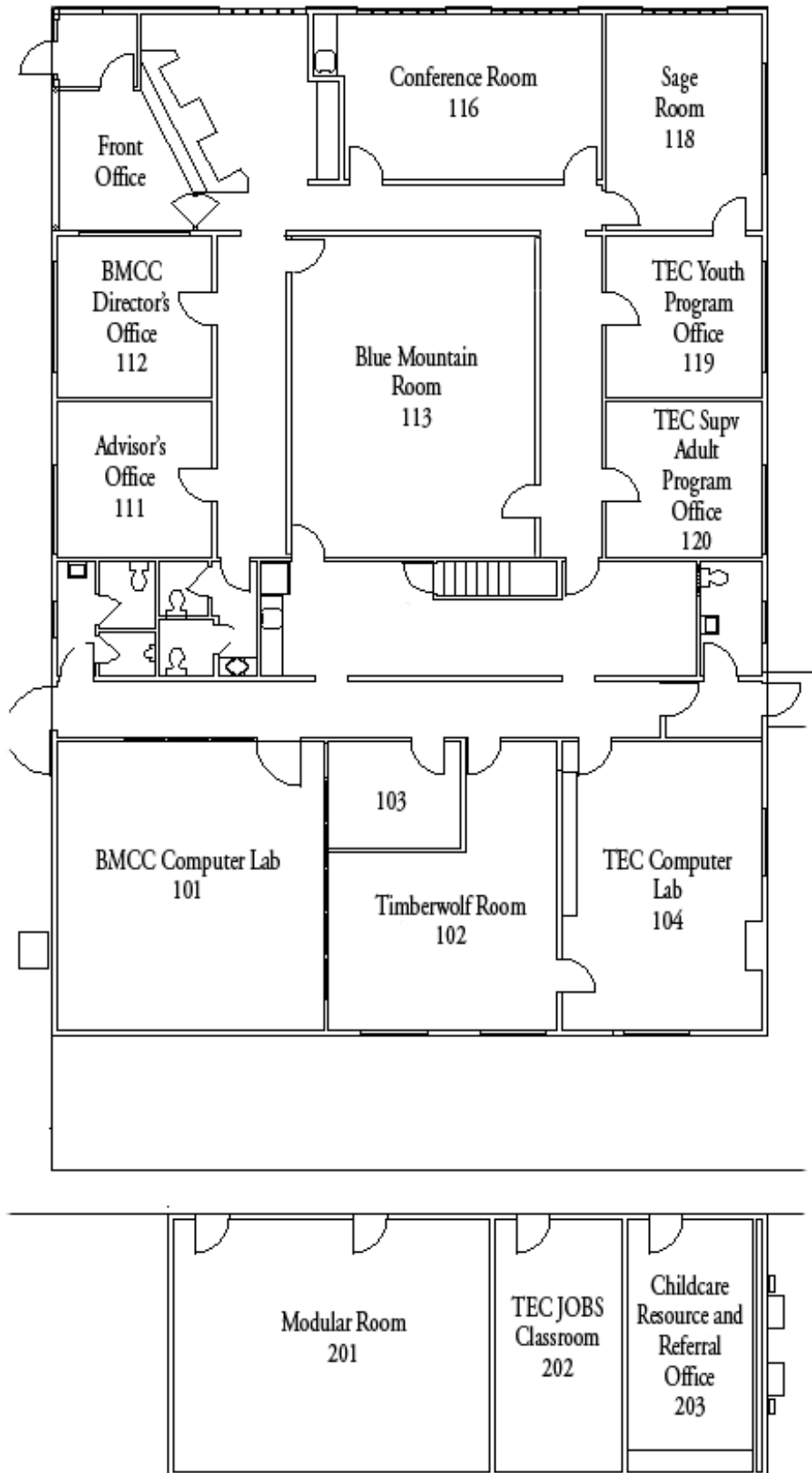

BMCC Phone Directory

(Area Code: 541)

BMCC Services

Advising.....	278-5931
Ambassadors.....	278-5936
Art Gallery, Betty Feves	278-5952/5944
Athletics.....	278-5900/5896
Bookstore	278-5733
Box Office (Theater).....	278-5953
Business Office.....	278-5744
Computer Services / Help Desk	966-3182
Cooperative Work Experience.....	278-5969/5763
Copy Center	278-5966
Counseling (part-time)	278-5937
CTUIR / Tribal Liaison.....	278-5935
Disability Services.....	278-5807
Distance and Extended Learning	278-5763/5969
Enrollment Management.....	278-5759
EOU Distance Education	278-5776/5778
Financial Assistance to Students.....	278-5759
Food Services.....	278-5946
Foundation	278-5775/5930
Grants	278-5838/5930
Human Resources	278-5837
Inclement Weather Information	278-5970
Instruction, Office of	278-5930
Library	278-5915
Maintenance	278-5903/5904
Marketing and Public Relations.....	278-5933/5962
McCrae Activity Center	278-5900/5896
OSU Extension Office	278-5403
Operations.....	278-5154
President's Office.....	278-5951
Recruitment (Student).....	278-5936
Registrar.....	278-5757
Room Scheduling	278-5969
Service Center	278-5759
Small Business Development Center, Pendleton.....	278-5833
Student Employment.....	278-5165
Student Government Office / Student Activities	278-5948
Student Orientation.....	278-5934
TDD Hearing Impaired Hermiston	564-9248
Pendleton.....	278-2174
Testing	278-5931
Theater Box Office.....	278-5953
Title III Grant Project Office.....	278-5823
TRiO Student Support Services	278-5853/5852
Tutoring.....	278-5795/5803
Veterans' Assistance	278-5165
Weather Closure Information	278-5970
Web Coordination.....	278-5962

Academic Departments

Agriculture	278-5868
Apprenticeship	278-5854
Business Technologies	278-5868
Civil Engineering Technology.....	278-5868
College Preparatory Programs.....	278-5803/5795
Computer Science	278-5814
Dental Assisting	278-5877
Diesel Technology	278-5748
Early Childhood Education.....	278-5957
Education	278-5802
English	278-5944
Fine Arts.....	278-5944
Mathematics	278-5814
Nursing	278-5877
Physical Education	278-5877
Science.....	278-5788
Social Science	278-5944

BMCC Location Specific Services

BMCC Baker County.....	523-9127 or 276-1260x3201
BMCC Grant County	575-1550
BMCC Hermiston	567-1800 or 276-1260x3303
BMCC Milton-Freewater.....	938-4082 or 276-1260x3171
BMCC Morrow County - Boardman.....	481-2099
BMCC Morrow County - Lone	422-7040
BMCC Wallowa County.....	426-4109
College Preparatory Programs	
Baker City.....	523-9127
Boardman.....	481-2099
Hermiston	567-6615
Milton-Freewater	938-4082
Pendleton.....	278-5803
JOBS Programs	
Hermiston	567-0490
Milton-Freewater	938-4082 ext. 7175
Pendleton	276-9050 ext. 229
Small Business Development Center, Hermiston	564-9021ext. 3341
Community Corrections Education.....	276-7824 Ext. 249
Eastern Oregon Correctional Institution (EOCI Ed.).....	278-7102
Powder River Correctional Institution (PRCI Ed.).....	278-7102
Three Rivers Correctional Institution (TRCI Ed.)	922-6135

BMCC



Make 'em cry Wolf!